

Flow limiter SP/SMB14

for line installation in circulating-oil lubrication systems.



Flow limiters are used in circulating-oil lubrication systems. The task of a flow limiter is to divide up the volumetric flow of the main line into parallel individual volumetric flow quantities and to "limit" these according to requirements, or to keep them constant. The volumetric flow produced does not depend on the system pressure and is nearly independent of viscosity.

Using interchangeable plug-in nozzles, the volumetric flow of the flow limiter SP/SMB14 can be set stepwise **from 25 to 132 l/min**. That makes it possible to adjust the volumetric flow rates at a later date. The SP/SMB14 group comes with a visual/electric gear wheel-type flow indicator that has a proportional factor of 106 ml per revolution.

Advantages

- **reliable**
 - Parallel distribution of individual flow quantities
 - Self-regulating metering, thus even volumetric flows for different back pressures
 - Wide viscosity spectrum, practically independent of temperature and viscosity, thus stable system conditions.
- **easy system planning**

The required volumetric flow (the required flow limiter nozzle) has to be determined already during the project planning phase.
- **simple start-up**

Preset volumetric flows allow short start-up times.
- **effective volumetric flow control by means of gear wheel-type flow indicator with Hall-Sensor**
- **broad range of applications**
- **optional ATEX version**
- **stable and reproducible measuring procedure, no corrective factor required**

Design

The SP/SMB14 flow limiter consists of the following:

- Flow limiter housing (with sensor) flow limiter regulating assembly (with control piston, plug-in nozzle and pressure spring)
- Gear pair
- Flow limiter cover (with sight glass, seals, plugs and fastening screws).

The housing, gears and cover consist of an anodized aluminum alloy that results in corrosion-resistance and low weight. A round glass disk conforming to DIN 8902 (temperature stable pressed hard glass) is used for the sight-glass pane. The pane floats in the cover to avoid distortion and premature failure. The cover also accommodates a sensor that is actuated by two pin magnets embedded in the gear below. The plug-in nozzle in the flow limiter regulating assembly is simply interchangeable, as soon as the closing screw lying under the plug is unscrewed from the housing.

Dimension drawing

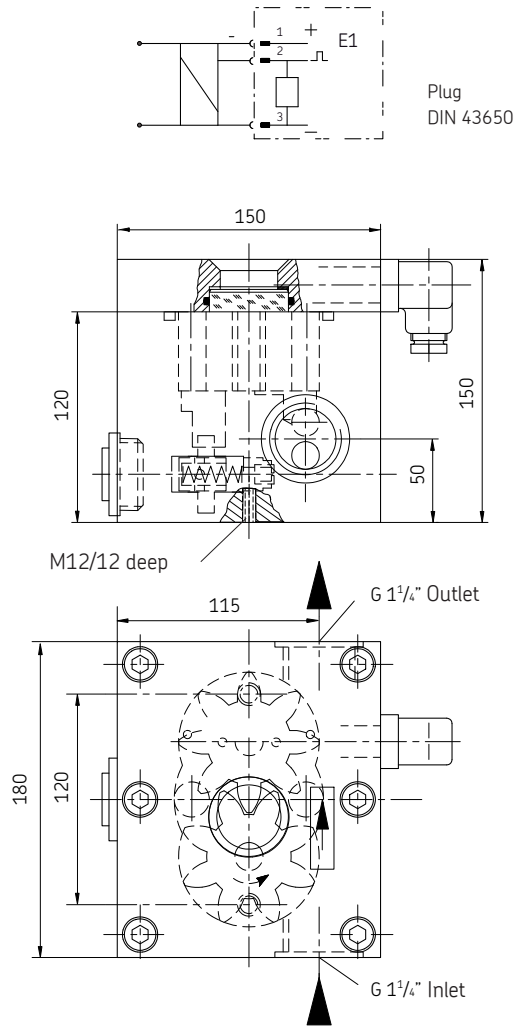

Mode of operation

The flow limiter SP/SMB14 has two restrictors connected in series (D_1 , D_2). Restrictor D_1 involves an interchangeable plug-in nozzle, which as a nonadjustable restrictor defines the nominal volumetric flow. The nonadjustable restrictor D_1 is available in different nozzle sizes (refer to table on page 4). On the contrary, restrictor D_2 is an adjustable restrictor, which has a different restrictor cross-section based on the position of the control piston RK. The flow resistance of restrictor D_2 is automatically changed in such a manner by shifting the control piston (RK) against the spring force (F), that the differential pressure on the nonadjustable restrictor D_1 remains constant, and thus also the volumetric flow.

$$p_1 \cdot A = p_2 \cdot A + F \quad \text{resp.} \quad p_{1/2} = p_1 - p_2 = F/A = \text{constant}$$

It follows that:

The difference in pressure in front of and behind the plug-in nozzle is held constant by the control piston (RK).

For this function, the system pressure p_1 must always be greater than the sum of the pressure drops in and downstream of each flow limiter.

$$p_1 > p_{1/2} + p_3$$

For this reason, the pump's volumetric flow should exceed all the individual flow quantities by approx. 15 %, i.e.,

$$Q = 1,15 \cdot (\sum Q_i).$$

The downstream gear wheel-type flow indicator uses a dynamic pulse generator (24 V DC) to emit a continuous sequence of pulses proportional to the volumetric flow.

The proportionality factor $K1$ is derived from the swallowing capacity of one revolution of the gear pair ($K1 = 106 \text{ ml/pulse}$).

The sequence of pulses can be displayed and monitored by pulse-monitoring equipment, group monitoring units or a central evaluation station.

Due to the very short throttle length of the plug-in nozzle D_1 the control performance in the indicated viscosity range is almost independent of temperature and viscosity.

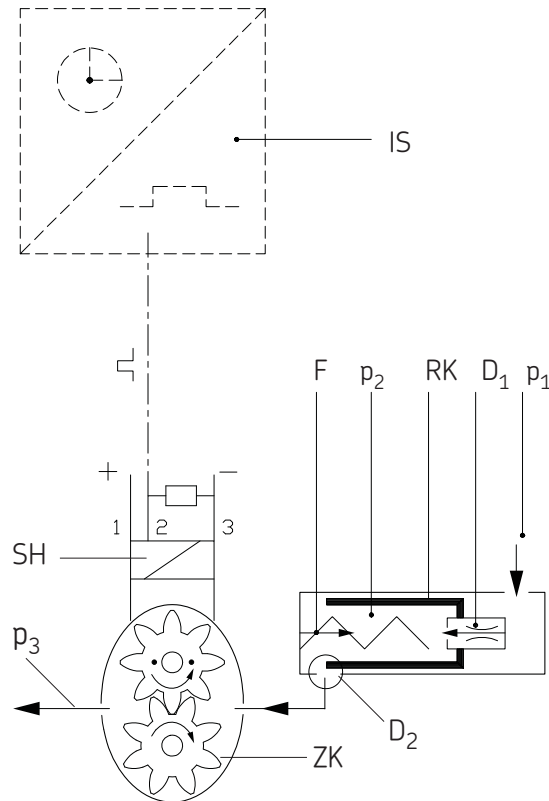

- | | | | |
|-------|---|-----------|--------------------------------|
| p_1 | Pressure upstream of the plug-in nozzle D_1 | RK | Control piston |
| p_2 | Pressure downstream of the plug-in nozzle D_1 | ZK | Gear wheel-type flow indicator |
| p_3 | Pressure downstream of ZK (outlet pressure) | SH | Pulse generator |
| D_1 | Plug-in nozzle | IS | Pulse control and display |
| D_2 | Adjustable restrictor | F | Spring force |

Technical Data

		Flow limiter
General information		
Type	2-way flow limiter valve with volumetric flow check	Required differential pressure between inlet p_1 and outlet p_3 ≥ 6 bars
Application	for line installation	Lubricant mineral oils, synthetic oils and ecofriendly oils
Mounting position	any	Lubricant temperature range 0 to + 90 °C ¹⁾
Ambient temperature range	0 to +70 °C	Operating viscosity 20 to 600 mm ² /s
Material	AlCuPb F38, neutrally anodized	Gear wheel-type flow indicator
Weight	7.8 kg	Sensor Hall-Sensor
Hydraulic		
Nominal volumetric flow	stepwise from 25 to 132 l/min (see table on page 4)	System voltage 24 V DC \pm 10%
Working pressure p_1	6 to 50 bars	Max. switched current 20 mA
		Connection plug, DIN 43 650
		Protection class IP 65
		Proportionality factor 106 ml/pulse
		¹⁾ Only when ambient temperature < +60 °C

Plug-in nozzle table

Plug-in nozzle table				
Nominal volumetric flow ¹⁾ [l/min]	Nozzle [Ø mm]	Type nozzle	Nozzle index	Spare part complete plug-in nozzle D ₁ Order no.
25	5.70	0570	570	44-0455-2357
30	6.30	0630	630	44-0455-2360
35	6.80	0680	680	44-0455-2363
40	7.30	0730	730	44-0455-2365
45	7.80	0780	780	44-0455-2367
50	8.20	0820	820	44-0455-2369
55	8.70	0870	870	44-0455-2371
60	9.10	0910	910	44-0455-2373
65	9.60	0960	960	44-0455-2374
70	10.00	1000	000	44-0455-2375
75	10.40	1040	040	44-0455-2376
80	10.80	1080	080	44-0455-2377
90	11.70	1170	170	44-0455-2378
100	12.70	1270	270	44-0455-2379
105	13.10	1310	310	44-0455-2385
110	13.50	1350	350	44-0455-2380
116	14.00	1400	400	44-0455-2381
120	14.40	1440	440	44-0455-2386
132	15.30	1530	530	44-0455-2382

¹⁾ at a service viscosity of 300 mm²/s

Note!

For ordering a flow limiter SP/SMB14, the customer must generate a type designation as well as an order no. This must be adjusted in accordance with the desired flow limiter design.

The key to the order codes on page 5 illustrates the structure of the type designation and the order number. For the required nozzle index, see plug-in nozzle table.

Key to order codes

Order example

Flow limiter, type SP/SMB and size 14 (**SP/SMB14**) outfitted with nozzle (**2**), with optical/electrical monitoring (gear wheel-type flow indicator) with Hall-Sensor (**E1**), with a volumetric flow of 65 l/min and a nozzle diameter of 9.6 mm (nozzle index **960**) gives the

Type designation: **SP/SMB14/2E1/960**
and

Order number: **24-2714-4960**

Note

The following flow limiters, type SP/SMB14, are available in ATEX design:



possible design features:

- Housing design with ground terminal
- rating plate, extended
- can be used only in connection with a circuit breaker device
- can be ordered with ATEX certificate

Restrictions regarding temperature and explosion class must be observed.

Further details can be obtained from
SKF Lubrication Systems Germany GmbH

Type designation:

SP/SMB14/2 .. /

Order number:

24-2714-

Structure of the type designation for flow limiter

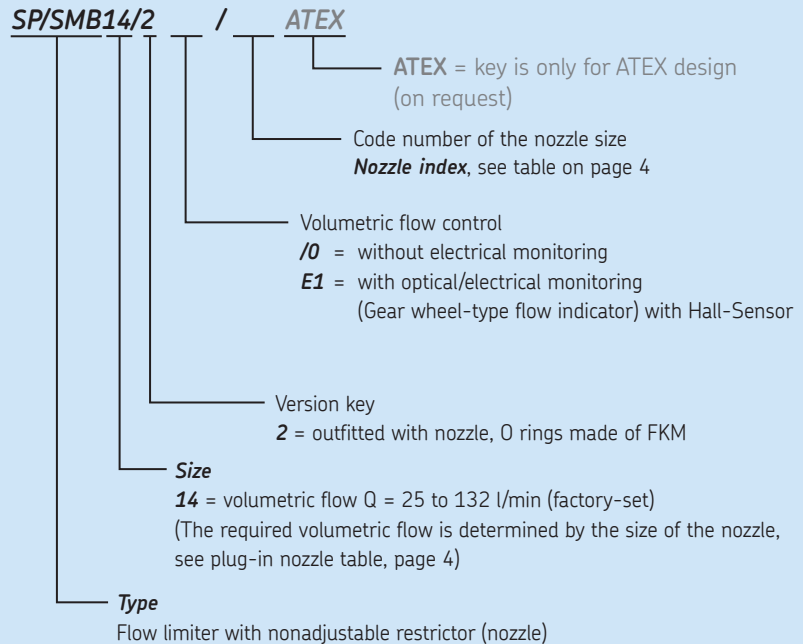

Structure of the order number for flow limiter

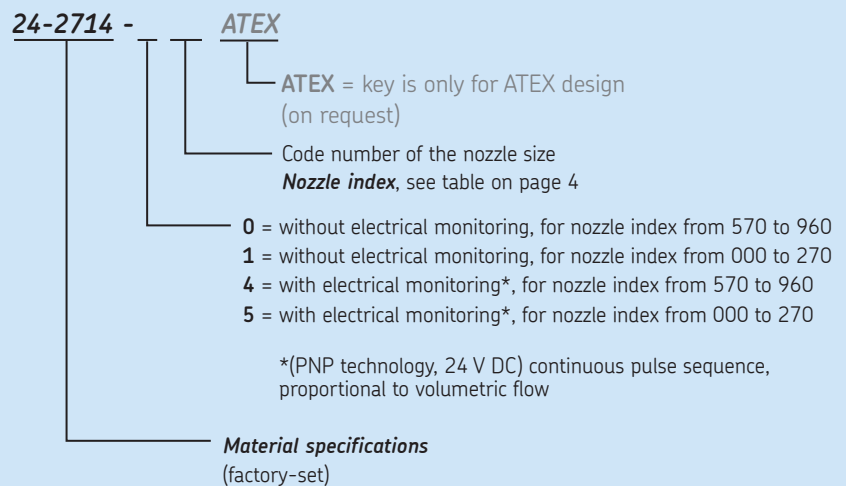

Example of a circulating-oil lubrication system

Pump (1) delivers the lubricant to the main line (2). From the flow limiters arranged in parallel (3), the lubricant reaches the lubrication points directly.

The pump's volumetric flow should be at least 15 % greater than the sum of nominal volumetric flows of all connected flow limiters. The pressure-regulating valve integrated into the main line (4) assumes the system pressure regulation.

The gear wheel-type flow indicator (5) integrated in the flow limiters (3) controls the volumetric flow. Display and control of the pulse sequence (flow limiters (3)) is done by a group monitoring unit (6) or a central evaluation station.

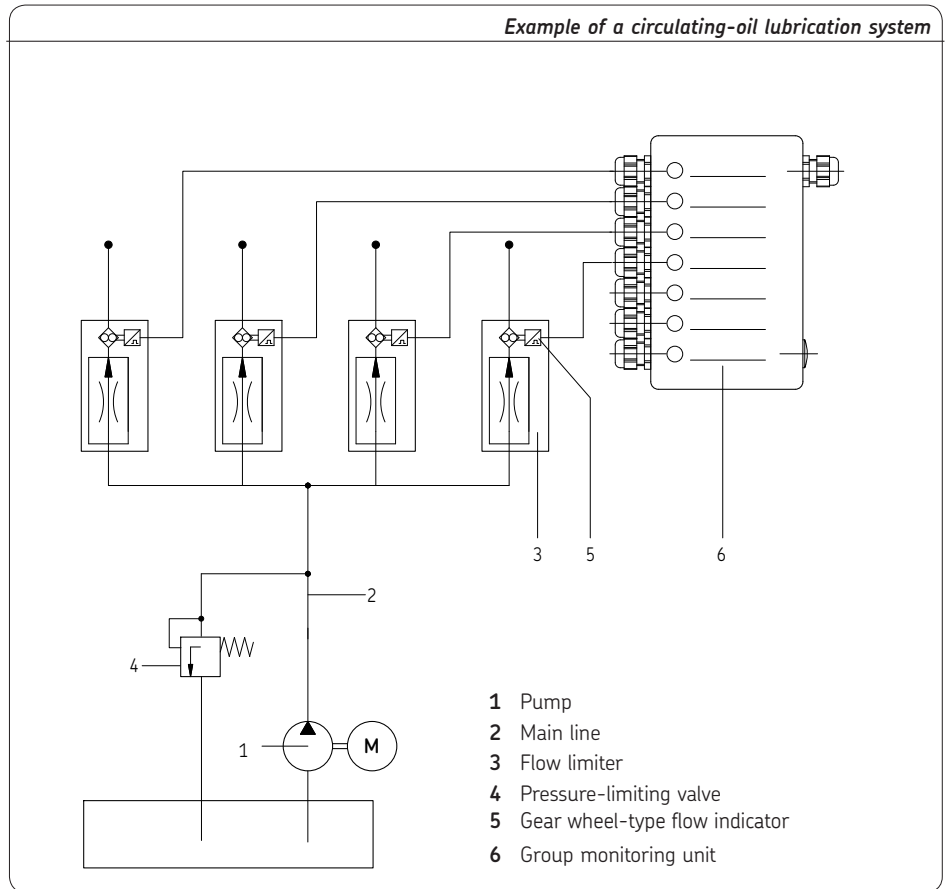

Replacing plug-in nozzles

- Interrupt oil feed of flow limiter (1)

⚠ WARNING

Burning oil hazard.

Failure to slowly remove screw could result in burns.

- Remove screw plug (2) with hexagon socket screw key (SW 10) and pull it out carefully with plug-in nozzle (4) from the flow limiter housing
- ⚠ A brass fitting wedge (never use a hard object like, for instance, a screwdriver) ought to be used to help press out the plug-in nozzle.
- Place the fitting wedge between screw plug (2) and plug-in nozzle (4) and press out the old plug-in nozzle
- Press new plug-in nozzle on a level board without skewing on screw plug (2)
- Place screw plug (2) on flow restrictor thread and tighten with hexagon socket screw key
- Open oil feed to flow limiter

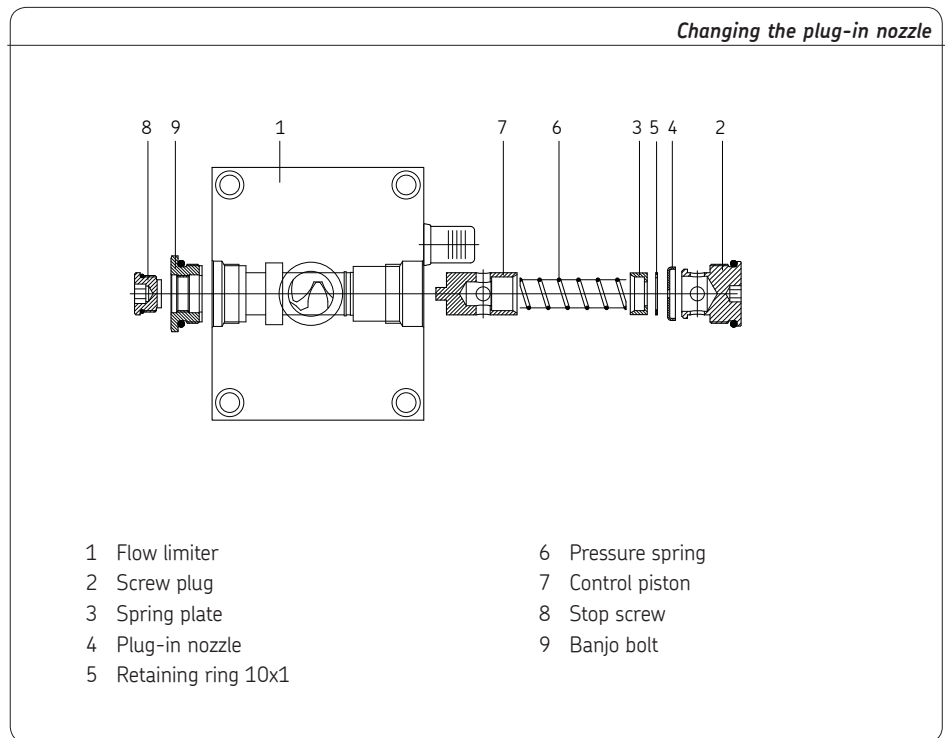

Note

In the case of a change in the nozzle size, the nozzle specifications on the rating plate must be changed accordingly.

Accessories/spare parts

<i>Accessories</i>	
<i>Designation</i>	<i>Order no.</i>
Pulse meter IPM 12	84-8011-0380
Pulse meter with connection socket for PGA 3	84-8011-0390
<i>Spare parts</i>	
<i>Designation</i>	<i>Order no.</i>
Flow limiter SP/SMB14 without nozzle, with electrical monitoring	24-1883-3017
Sight glass D 45x12	44-0758-2049
Gasket set for SP/SMB 14 consisting of: Flat gasket D 32/45x0.5 O-ring 44x3 O-ring 90x3	24-0404-2311
Socket	24-1882-2029

Order No. 1-3005-EN

Subject to change without notice! (05/2017)

Important product usage information

All products from SKF may be used only for their intended purpose as described in this brochure and in any instructions. If operating instructions are supplied with the products, they must be read and followed.

Not all lubricants are suitable for use in centralized lubrication systems. SKF does offer an inspection service to test customer supplied lubricant to determine if it can be used in a centralized system. SKF lubrication systems or their components are not approved for use with gases, liquefied gases, pressurized gases in solution and fluids with a vapor pressure exceeding normal atmospheric pressure (1013 mbars) by more than 0.5 bar at their maximum permissible temperature.

Hazardous materials of any kind, especially the materials classified as hazardous by European Community Directive EC 67/548/EEC, Article 2, Par. 2, may only be used to fill SKF centralized lubrication systems and components and delivered and/or distributed with the same after consulting with and receiving written approval from SKF.

Additional brochures

1-3027-EN	Overview brochure - Flow limiter	
1-3001-EN	Flow limiter SP/SMB3	6 to 38 l/min signal transmitter and proximity switch
1-3001-EN	Flow limiter SP/SMB6	25 to 132 l/min signal transmitter and proximity switch
1-3028-EN	Flow limiter SP/SMB8	0,09 to 8,18 l/min Sensor and piston detector
1-3002-EN	Flow limiter SP/SMB9	0,09 to 8,18 l/min Gear wheel-type flow indicator
1-3003-EN	Flow limiter SP/SMB10	0,21 to 8,15 l/min Gear wheel-type flow indicator
1-3004-EN	Flow limiter SP/SMB13	6 to 38 l/min Gear wheel-type flow indicator
1-1730-EN	Electrical plug-in connections	

SKF Lubrication Systems Germany GmbH

2. Industriestrasse 4 · 68766 Hockenheim · Germany

Tel. +49 (0)62 05 27-0 · Fax +49 (0)62 05 27-101

www.skf.com/lubrication

This brochure was presented by:

® SKF is a registered trademark of the SKF Group.

© SKF Group 2017

The contents of this publication are the copyright of the publisher and may not be reproduced (even extracts) unless prior written permission is granted. Every care has been taken to ensure the accuracy of the information contained in this publication but no liability can be accepted for any loss or damage whether direct, indirect or consequential arising out of the use of the information contained herein.

