

# SKF composite plain bearings

Compact and maintenance-free





The SKF® brand now stands for more than ever before, and means more to you as a valued customer.

While SKF maintains its leadership as the hallmark of quality bearings throughout the world, new dimensions in technical advances, product support and services have evolved SKF into a truly solutions-oriented supplier, creating greater value for customers.

These solutions encompass ways to bring greater productivity to customers, not only with breakthrough application-specific products, but also through leading-edge design simulation tools and consultancy services, plant asset efficiency maintenance programmes, and the industry's most advanced supply management techniques.

The SKF brand still stands for the very best in rolling bearings, but it now stands for much more.

**SKF – the knowledge engineering company**

# Contents

## A Product information

- 3 Compact and maintenance-free**
- 3 Characteristics
- 3 The assortment
- 6 Materials
- 8 Machinability of composite materials
- 9 Friction
- 9 Chemical properties
- 9 Electrical properties

## B Recommendations

- 10 Selection of bearing size**
- 10 Basic load ratings
- 11 Basic rating life
- 11 Requisite bearing size
- 13 Calculating basic rating life
  
- 15 Application of bearings**
- 15 Material and surface finish of counterfaces
- 15 Shaft and housing tolerances
- 23 Design of associated components
- 24 Seals
  
- 25 Lubrication**
- 25 PTFE composite bearings
- 25 POM composite bearings

## 26 Mounting

## C Product data

- 27 Bearing data – general**
  
- 28 Product tables**
- 28 Metric composite straight bushings
- 38 Inch composite straight bushings
- 42 Composite flanged bushings
- 43 Composite thrust washers
- 44 Composite strips

## D Additional information

- 45 Related SKF products**
  
- 49 Application examples**
  
- 58 SKF – the knowledge engineering company**

# Compact and maintenance-free

Composite plain bearings are primarily used for bearing arrangements where heavy loads have to be supported and where rotational or oscillating movements are relatively slow. Because of their good sliding properties and compact design, these plain bearings are particularly suitable for bearing arrangements where

- maintenance-free operation is a prerequisite
- there is a risk of lubricant starvation
- lubricants can not be used or are forbidden
- space is limited.

Typical application examples for SKF composite plain bearings can be found on **pages 49 to 57**.

## Characteristics

The important characteristics of SKF composite plain bearings include

- maintenance-free
- no lubrication required (PTFE composite)
- initial lubrication required (POM composite)
- minimum wall thickness, minimum space requirements
- accommodation of heavy loads
- wide range of operating temperatures
- good sliding properties
- virtually no stick-slip
- high wear-resistance
- less sensitive to edge loading (POM composite)
- no machining required.



## The assortment

The standard range of SKF composite plain bearings is very comprehensive and covers almost every standard size. The range is shown in the product overview in **table 1** and comprises

- straight bushings
- flanged bushings
- thrust washers
- strips.

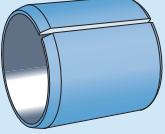
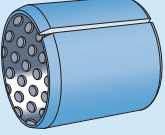
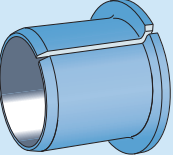

Table 1

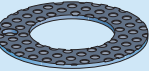
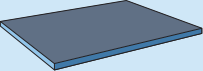
Bearing type	Series	Bore diameter range	Lubrication	Operating temperature range
<b>Straight bushings</b>				
<b>PTFE composite</b>				
	PCM .. E	3–300 mm	None	–200 to +250 °C
	PCZ .. E	1/8–7 in	None	–200 to +250 °C
<b>POM composite</b>				
	PCM .. M	8–300 mm	Initial lubrication only	–40 to +110 °C short periods +130 °C
	PCZ .. M	3/8–4 in	Initial lubrication only	–40 to +110 °C short periods +130 °C
<b>Flanged bushings</b>				
<b>PTFE composite</b>				
	PCMF .. E	6–35 mm	None	–200 to +250 °C
<b>Thrust washers</b>				
<b>PTFE composite</b>				
	PCMW .. E	12–62 mm	None	–200 to +250 °C
<b>POM composite</b>				
	PCMW .. M	12–52 mm	Initial lubrication only	–40 to +110 °C short periods +130 °C
<b>Strips</b>				
<b>PTFE composite</b>				
	PCMS .. E	500 × 200 mm Height: 1 to 3,06 mm	None	–200 to +250 °C
<b>POM composite</b>				
	PCMS .. M	500 × 200 mm Height: 1 to 3,06 mm	Initial lubrication only	–40 to +110 °C short periods +130 °C

		Continuation of table 1
Series	Characteristics	Product table on page
PCM .. E	Metric straight bushings of triple-layer PTFE composite material, (→ page 6). Suitable for bearing arrangements that have to support radial loads only. For slow rotational or oscillating movements. Initial lubrication not required. Maintenance-free.	28
PCZ .. E	Inch straight bushings of triple-layer PTFE composite material,(→ page 6). Suitable for bearing arrangements that have to support radial loads only. For slow rotational or oscillating movements. Initial lubrication not required. Maintenance-free.	38
PCM .. M	Metric straight bushings of triple-layer POM composite material (→ page 6). Suitable for bearing arrangements that have to support radial loads only. For slow rotational or oscillating movements as well as linear movements. Initial lubrication required. Maintenance-free, except where there is a risk of misalignment, edge loading or moderate to severe contamination.	28
PCZ .. M	Inch straight bushings of triple-layer POM composite material (→ page 6). Suitable for bearing arrangements that have to support radial loads only. For slow rotational or oscillating movements as well as linear movements. Initial lubrication required. Maintenance-free, except where there is a risk of misalignment, edge loading or moderate to severe contamination.	38
PCMF .. E	Metric flanged bushings, made of triple-layer PTFE composite material, (→ page 6). Suitable for bearing arrangements that have to accommodate radial loads and axial loads in one direction. For slow rotational and oscillating movements. Maintenance-free. No lubrication required.	42
PCMW .. E	Metric thrust washers of triple-layer PTFE composite material, (→ page 6). Suitable for space-saving axial locating bearing arrangements. For slow rotational or oscillating movements. Initial lubrication not required. Maintenance-free.	43
PCMW .. M	Metric thrust washers of triple-layer POM composite material (→ page 6). Suitable for space-saving axial locating bearing arrangements. For slow rotational or oscillating movements. Initial lubrication required. Maintenance-free except where there is a risk of edge loading or moderate to severe contamination.	43
PCMS .. E	Strips of triple-layer PTFE composite material, (→ page 6). The strips can be bent, pressed, cut etc. to fit the application. Suitable for space-saving arrangements of all types. Initial lubrication not required. Maintenance-free.	44
PCMS .. M	Strips of triple-layer POM composite material (→ page 6). The strips can be bent, pressed, cut etc. to fit the application. Suitable for space-saving plain bearing arrangements of all types and where there is a risk of moderate contamination or edge loading. Initial lubrication required.	44

# Materials

There are two standard types of composite material for SKF plain bearings: PTFE composite and POM composite. Each is suitable for different applications.

## PTFE composite

PTFE composite bearings consist of a sheet steel backing on which a 0,2 to 0,4 mm thick porous layer of tin/bronze is sintered (→ **fig. 1**). By a rolling process, the pores of the sintered layer are filled with a mixture of PTFE (polytetrafluoroethylene) and molybdenum disulphide (designation suffix E).

An additional 5 to 30 µm thick running-in layer of the mixture is then applied to the sintered tin/bronze. This additional layer provides an optimum combination of the mechanical properties of the sintered tin/bronze and the good sliding and lubricating properties of the PTFE mixture. PTFE composite bearings have good dimensional stability and thermal conductivity.

## POM composite

Like PTFE composite bearings, POM composite bearings also have a sheet steel backing that is covered with a 0,2 to 0,4 mm thick layer of sintered tin/bronze (→ **fig. 2**). The principal characteristic of these bearings is their relatively thick (0,3 mm) layer of acetal resin (POM – polyoxymethylene) that is firmly attached to the sintered tin/bronze layer. The covering layer has pockets to retain grease.

The thickness of the covering layer makes these bearings less sensitive to misalignment and the edge loading associated with that misalignment.

*PTFE composite material*

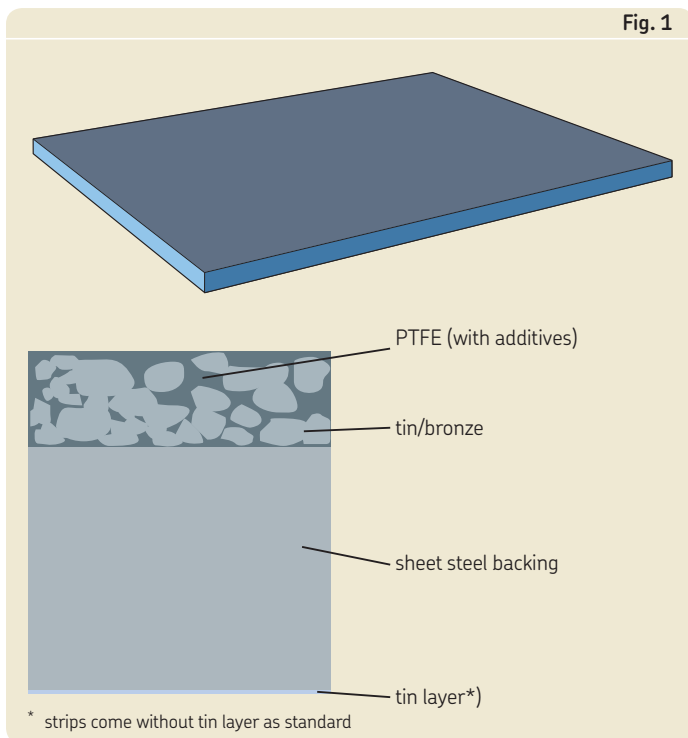

*POM composite material*

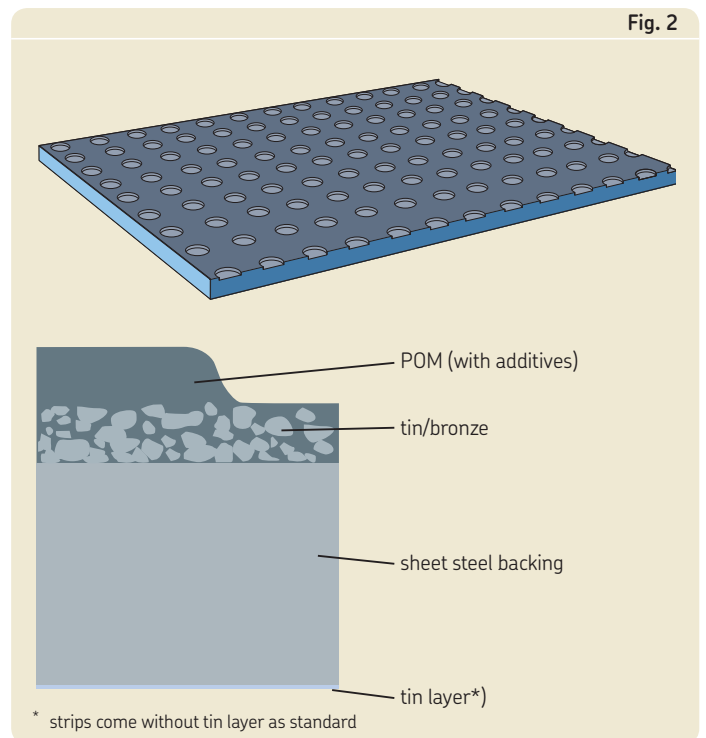

## Summary of characteristics of SKF PTFE composite and POM composite materials

Characteristics	PTFE composite	POM composite
Composition	<b>Material variant E</b> Steel backing with a layer of sintered tin/bronze; pores filled and covered with a layer (5 to 30 µm) of PTFE with molybdenum disulphide additives	<b>Material variant M</b> Steel backing with a layer of sintered tin/bronze; pores filled and covered with a layer (0,3 mm) of POM
Permissible specific static bearing load (N/mm <sup>2</sup> )	250	250
Permissible specific dynamic bearing load (N/mm <sup>2</sup> )	80	120
Maximum sliding velocity (m/s)	2	2,5
Operating temperature range (°C)	-200 to +250	-40 to +110 (+130 for short periods)
Coefficient of friction	0,03 to 0,25	0,02 to 0,20
Stick-slip effect	Negligible	Negligible
Wear layer thickness (mm)	0,2	0,3
Lubrication	Not required	Initial lubrication required
Ability to support edge loads (e.g. resulting from misalignment)	Fair	Good
Ability to carry alternating loads	Good	Fair
Ability to accommodate linear movements	Fair	Good
Machining of sliding surface after mounting	Calibration	Drilling, turning, (reaming)
Recommended housing tolerance for metric bushings	H7	H7
Recommended shaft tolerance for metric bushings	f7 (for d ≤ 75 mm) h8 (for d > 75 mm)	h8 (h7)
Required surface roughness of mating surface (µm)	R <sub>z</sub> ≤ 3 R <sub>a</sub> ≤ 0,4	R <sub>z</sub> ≤ 6 R <sub>a</sub> ≤ 0,8
Permissible surface machining of mating surface	Commercial shafts (ground or drawn)	Commercial shafts (drawn or fine turned)

## Machinability of composite materials

With the exception of the sliding layer, SKF composite bushings can be machined using conventional methods.

If bushings are required to have a smaller width than the standard size, this can easily be achieved by turning. It is also possible to drill lubrication holes. However, any burrs must be removed, particularly from the sliding surface.

Strips can be bent, pressed, cut, or drilled to fit the individual application. When cutting or drilling, it is advisable to work from the sliding surface side to avoid creating burrs in the sliding layer.

Any metal surfaces that are exposed as a result of machining should be protected against corrosion.

### Calibrating mandrel

$d_k$  = diameter of the calibrating mandrel

$B$  = bushing width

Minimum hardness: 50 HRC

Surface roughness:  $R_z \approx 1 \mu\text{m}$

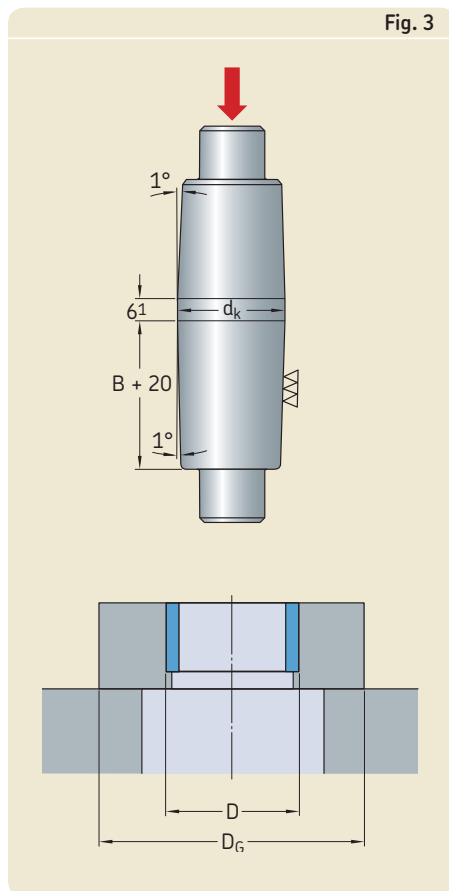

Fig. 3

## Machining the bore of PTFE composite bushings

PTFE composite bushings conform to ISO 3547:2006 and are ready for installation. Any re-sizing of the bore, i.e. the sliding surface, will reduce the service life of the bushings and should only be done in exceptional cases. If re-sizing is necessary, the bore should be calibrated, using a mandrel/resizing tool ( $\rightarrow$  fig. 3).

Because various criteria, like material and wall thickness of the housing as well as the deviation of cylindrical form, have to be taken into consideration, SKF recommends using a calibrated mandrel to re-size the bore. After resizing, bushing bore expansion tests and application field tests should be undertaken prior to the release of a final product. When machining the calibrating mandrel, the diameter  $d_k$  should be made in a first step about 60 to 80  $\mu\text{m}$  larger than the maximum value listed in the column "Bore diameter of mounted bushing" in table 1 on page 16.

Guideline values for the requisite interference of the calibrating mandrel as a function of the desired widening of the bushing bore for various bushing bore diameters can be obtained from diagram 1. The diagram is based on tests with bushings of different sizes and valid for bushings mounted in a housing with an outside diameter  $D_G = 2 \times$  bushing outside diameter  $D$  ( $\rightarrow$  fig. 3). If mandrel expansion tests show that the bore is too wide, the calibrating mandrel should be reground and the tests repeated on new bushings.

## Machining the bore of POM composite bushings

Bushings made of POM composite material are ready for installation. However, if necessary, the bushing bore can be machined to size while mounted in its housing. After machining the bore, the sliding surface should have an  $R_a$  value of max 2,5  $\mu\text{m}$ . The following machining recommendations will provide good results when a poly-crystalline diamond cutting tool is used

- cutting speed > 150 m/min
- slow feed rate (0,05 to 0,1 mm/revolution)
- cutting depth 0,1 mm.

To prevent excessive heat build-up of the acetal resin, and to remove the swarf produced during machining, a constant supply of compressed air (at a low pressure) should be applied to the bushing during any machining operation.



# Friction

Load, sliding velocity and operating temperature are primary factors in determining the friction in composite plain bearings. Friction is also influenced by the roughness of the surface on which the bearing runs, the degree of contamination and the lubrication conditions.

For PTFE composite bearings, the coefficient of friction  $\mu$  lies between 0,03 and 0,25 depending on the operating conditions. Similar values are found for the POM composite material, but the presence or constant supply of lubricating fluids serves to decrease friction. The lowest values are normally obtained where there are high specific loads and low sliding velocities ( $\rightarrow$  guideline values for  $\mu$  in **diagram 2**). Under particularly unfavourable operating conditions, like light loads, high velocities or inadequate surfaces, the maximum guideline values may be exceeded. The coefficient of friction for PTFE composite bearings increases at temperatures above +100 °C.

Stick-slip effects are negligible for PTFE and POM bearings.

# Running-in

During a short running-in phase there will be some transfer of PTFE material from the covering layer to the counterface. After this transfer has taken place, the characteristic low friction and wear properties of these bearings will be obtained.

# Chemical properties

The steel backing and the sintered tin/bronze layer are the primary factors in determining the chemical resistance of SKF composite plain bearings, as the sliding (covering) layers are resistant to most chemicals. The covering layer is virtually inert because of its PTFE content, although at elevated temperatures molten alkali metals and free fluorine will attack it. The acetal resin-covering layer of the POM composite bearing is largely resistant to organic substances.

At room temperature the sintered tin/bronze structure has good resistance to sea water, steam, atmospheric influences, salt solutions and sulphuric acid, but not to oxidizing acids or media containing ammonia.

All exposed surfaces of the steel backing are electrolytically tin-plated but this provides

only limited protection against corrosion in most applications. In cases where the bearings are to be exposed to corrosive media, or where there is a danger of corrosion in the contact between the steel backing and the housing material, the backing can be protected by a nickel, chromium or zinc coating applied electrolytically. Further details can be supplied on request.

# Electrical properties

Bearings made from POM composite, because of their acetal resin-covering layer, may act as electrical insulators when new. To avoid the build-up of static electricity, components at risk should be grounded.

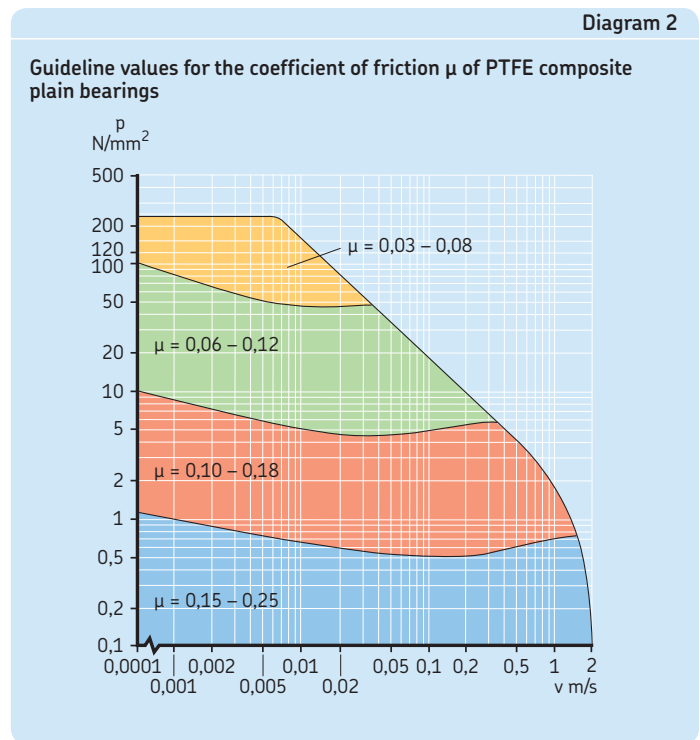
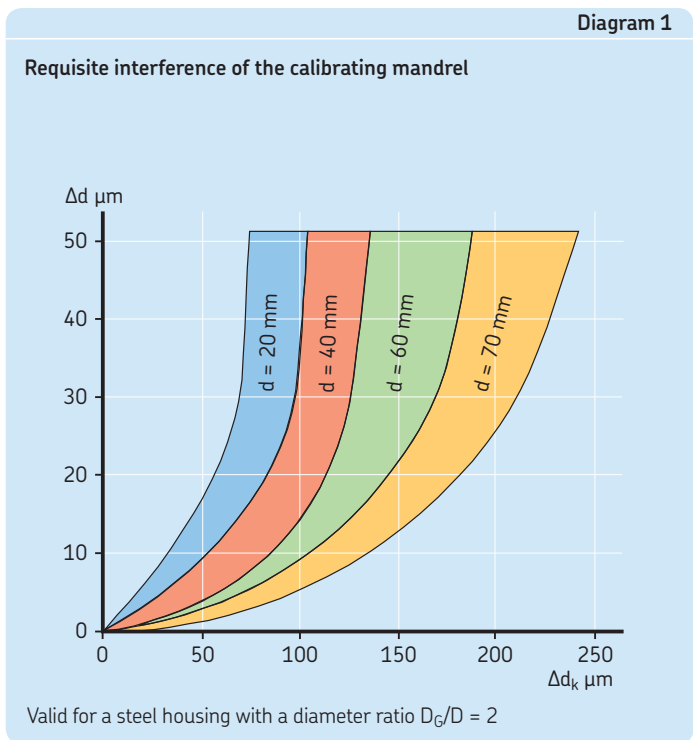

# Selection of bearing size

The load carrying ability and wear characteristics of SKF composite plain bearings are governed by the specific conditions of a particular application. Therefore, any calculation can only provide approximate values. In order to determine the required size of a bearing, the load carrying capacity, the applied loads, the rating life requirements and operational reliability must all be considered. The load carrying capacity is expressed by the basic dynamic load rating  $C$  and the basic static load rating  $C_0$ . Values of the load ratings can be found in the product tables.

## Basic load ratings

### Basic dynamic load ratings

The basic dynamic load rating  $C$  is used together with other influencing factors, to determine the basic rating life of a bearing. As a rule it represents the maximum load that a bearing can sustain at room temperature when the sliding contact surfaces are in motion. The maximum permissible load in any individual application should always be considered in relation to the desired rating life. The basic dynamic load ratings quoted in the product tables are based on the effective projected sliding surface and the specific load factor  $K$  that takes the different composite materials into consideration.

It is assumed in this definition that the load acting on a bushing or flanged bushing is purely radial and that the load acting on a thrust washer is purely axial and applied at the centre. Dynamic load conditions are essentially oscillating movements or rotations under load, but can include micro sliding under variable load (e.g. as a result of vibration) or operation under high frequency alternating loads. Where oscillating movements or rotation under load usually produce wear, the other conditions may result in fatigue.

### Basic static load ratings

The basic static load rating  $C_0$  is defined as the maximum load that an SKF composite bushing, flanged bushing or thrust washer can support when stationary at room temperature without permanently deforming the sliding layer and jeopardizing its performance. It is assumed that the bearing is adequately supported by the associated components of

the bearing arrangement. In order to fully exploit the static load rating of a bearing it is generally necessary to use shafts and housings made of high-strength materials. The basic static load rating must also be considered when bearings are dynamically loaded and are subjected to additional heavy shock loads. The total load in these cases must not exceed the basic static load rating.

Diagram 1

pv operating ranges for PTFE composite plain bearings

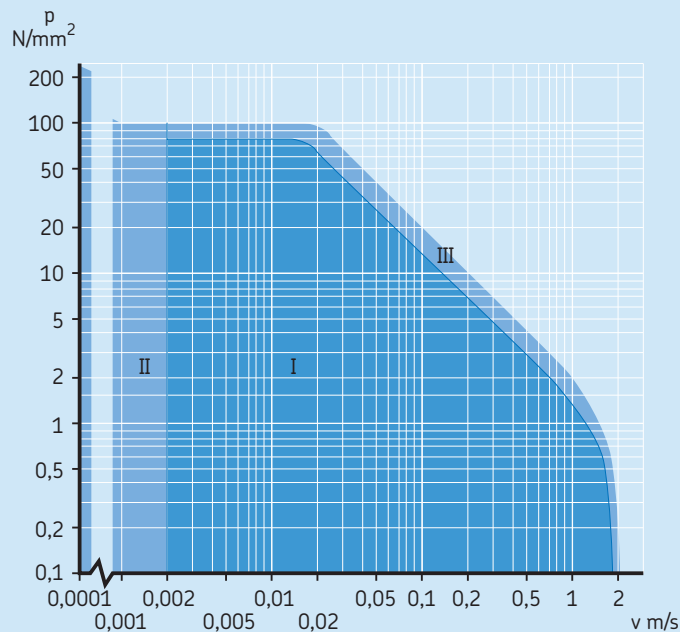

#### pv operating ranges

- I Basic rating life equation valid
- II Quasi-static range; SKF should be consulted before the rating life equation is used
- III Operation possible, e.g. if heat removal is very good; SKF should be consulted before the rating life equation is used

## Basic rating life

The basic rating life of a composite plain bearing is expressed in number of oscillations or revolutions, or in operating hours. It represents the operating period under test conditions that is ended when one of the criteria for the end of the basic rating life is reached

- increase in operating clearance
- plastic deformation of the sliding layer
- fatigue.

A distinction is made between the basic rating life and the service life actually achieved.

The basic rating life is a guideline value that will be attained or exceeded by the majority of a large number of apparently identical bearings under the same test conditions.

The service life actually achieved by apparently identical bearings under identical operating conditions has been found to differ both in laboratory endurance tests and in service at operating conditions. These include not only the magnitude and type of load but also other factors such as contamination, corrosion, load and movement cycles of high frequency and shock loads. These factors are difficult or even impossible to quantify.

## Requisite bearing size

The type and action mode of the load, the expected operating temperature, lubrication and maintenance requirements etc. all influence the choice of the bearing type and design.

To determine the requisite size of a composite plain bearing, start with the basic rating life for the application. The basic rating life will take the type of machine, the operating conditions, and operational reliability for that machine into consideration.

As a first approximation a guideline value of the load ratio  $C/P = 2$  can be used to obtain the requisite basic dynamic load rating  $C$ . A suitable bearing can then be selected from the product tables.

### pv operating range

Check whether the chosen size can be used under the actual load and sliding velocity conditions using **diagram 1** for PTFE composite or **diagram 2** for POM composite. The data required –  $p$  (specific bearing load) and  $v$  (sliding velocity) – can be calculated using the equations provided on **page 12**.

If the operating data lie within range I of the pv diagram, the basic rating life of the bearing can be determined using the equation provided in the section “Calculating basic rating life” on **page 13**. If the data lie within the range II or III of the diagram, either contact the SKF application engineering service or test the application to see if the bearing can be used. Alternatively, a different bearing can be chosen so that the values for  $p$  and  $v$  fall within range I.

For flanged bushings check the suitability of the bushing and flange separately.

Diagram 2

### pv operating ranges for POM composite plain bearings

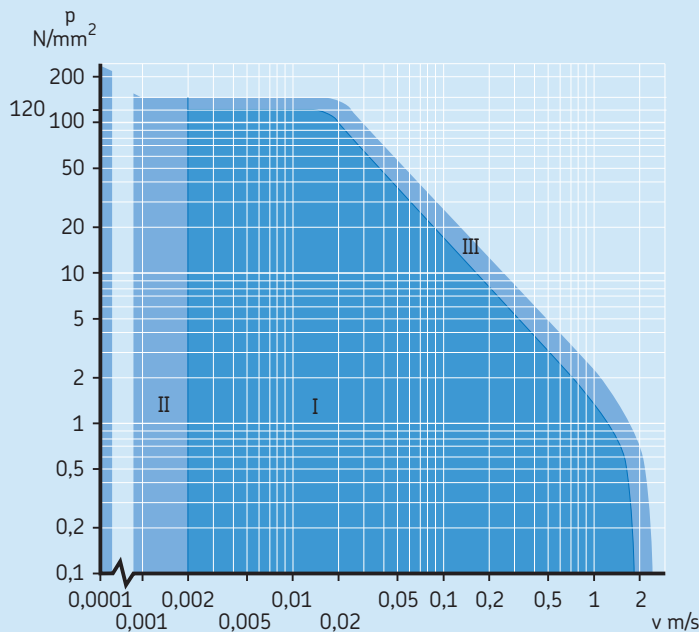

#### pv operating ranges

- I Basic rating life equation valid
- II Quasi-static range; SKF should be consulted before the rating life equation is used
- III Operation possible, e.g. if heat removal is very good; SKF should be consulted before the rating life equation is used

Diagram 3

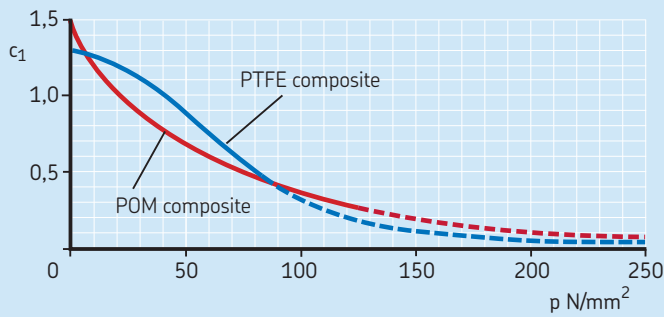
Load factor  $c_1$ 

## Determining specific bearing load

Specific bearing load can be determined from

$$p = K \frac{F}{C}$$

where

$p$  = specific bearing load,  $\text{N}/\text{mm}^2$

$F$  = dynamic bearing load,  $\text{kN}$

$C$  = basic dynamic load rating,  $\text{kN}$

$K$  = specific load factor,  $\text{N}/\text{mm}^2$

= 80 for PTFE composite material

= 120 for POM composite material

Diagram 4

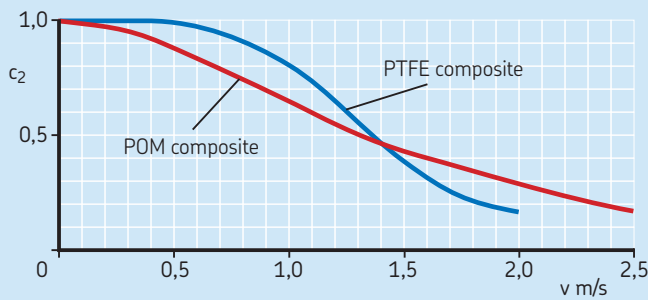
Speed factor  $c_2$ 

For flanged bushings, the specific load of the bushing and flange should be calculated separately. To calculate the specific load of the flange, replace  $C$  with  $C_a$  in the equation above. Values for  $C_a$  can be found in the product tables.

## Determining sliding velocity

The sliding velocity for SKF composite bushings and thrust washers can be obtained from

$$v = 5,82 \times 10^{-7} d \beta f$$

where

$v$  = sliding velocity,  $\text{m}/\text{s}$

$d$  = sliding diameter,  $\text{mm}$

– bushings and flanged bushings: bore diameter  $d$

– flange of flanged bushings: mean diameter =  $0,5 (d + D_1)$

– thrust washers: mean diameter =  $0,5 (d + D)$  or dimension  $J$  in the product table

$f$  = frequency of oscillation,  $\text{min}^{-1}$ , or rotational speed,  $\text{r}/\text{min}$

$\beta$  = half the angle of oscillation, degrees

( $\rightarrow$  fig. 1)

A complete oscillation (from point 0 to point 4) =  $4 \beta$ . For rotation, use  $\beta = 90^\circ$ .

Diagram 6

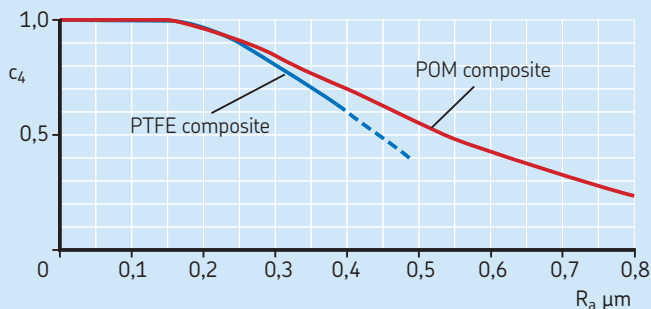
Surface roughness factor  $c_4$ 

## Calculating basic rating life

Many factors influence the life of a plain bearing, e.g. load, sliding velocity, operating temperature, surface roughness of the counter surface against which the composite sliding layer runs, etc. Any calculation is therefore only approximate.

The values obtained using the basic rating life equations are attained by the majority of bearings and are often exceeded. This has been confirmed by rig tests and field experience.

The basic rating life for SKF PTFE composite and POM composite plain bearings can be calculated from

$$G_h = c_1 c_2 c_3 c_4 c_5 \frac{K_M}{(pv)^n}$$

where

$G_h$  = basic rating life, operating hours

$c_1$  = load factor (→ **diagram 3**)

$c_2$  = speed factor (→ **diagram 4**)

$c_3$  = temperature factor (→ **diagram 5**)

$c_4$  = surface roughness factor

(→ **diagram 6**)

$c_5$  = factor for the type of load

= 1 for stationary load (i.e. the loaded zone is always at the same position on the bearing circumference)

= 1,5 for rotating load (i.e. the loaded zone moves round the circumference of the bearing)

$K_M$  = factor depending on material and bearing type

= 480 for PTFE composite bushings

= 300 for PTFE composite thrust washers

= 1 900 for POM composite bushings and thrust washers

$p$  = specific bearing load, N/mm<sup>2</sup>

$v$  = sliding velocity, m/s

$n$  = an exponent

= 1 for PTFE composite bushings and thrust washers

= 1 for  $pv \leq 1$  for POM composite bushings and thrust washers

= 3 for  $pv > 1$  for POM composite bushings and thrust washers

If loads are very light and/or sliding velocities are very low and the value of the product  $pv$

- for PTFE composite bearings is less than the limiting value of 0,025, then the limiting value  $pv = 0,025$  should be used for the life calculations
- for POM composite bearings is less than the limiting value of 0,1 then the limiting value  $pv = 0,1$ , should be used for the life calculations.

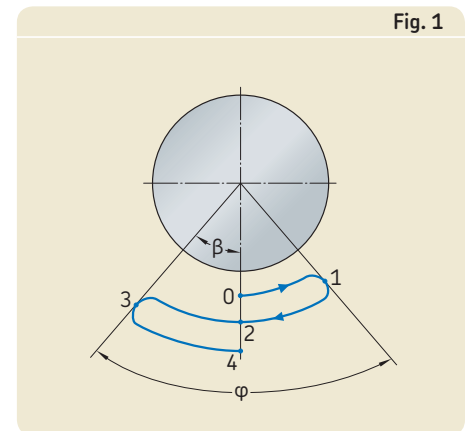

### Angle of oscillation

$\varphi$  = angle of oscillation =  $2 \beta$

A complete oscillation =  $4 \beta$

(from point 0 to point 4)

## Calculation example

Two paired PTFE composite bushings are to be used in the linkage of a locking system for the door of a tramway car.

Design data:

- Pin diameter:  $d = 20 \text{ mm}$
- Surface roughness of the pin:  $R_a = 0,4 \text{ }\mu\text{m}$

Operational data:

- Radial load at the linkage:
  - during closing 0,8 kN per bushing
  - after locking the closed door the static load mounts to 15 kN per bushing
- Half angle of oscillation  $\beta = 90^\circ$  (→ **fig. 1**)
- Frequency of oscillation:  $f = 10 \text{ min}^{-1}$
- Operating temperature:  $t = 30 \text{ }^\circ\text{C}$

Based on the design characteristics two PTFE composite bushings PCM 202325 E are chosen, having a basic dynamic load rating  $C = 39 \text{ kN}$  each.

Check whether the bushings can be used under the given operating conditions and which basic rating life can be achieved.

As a first check that the bearing size is suitable (→ **diagram 1** on **page 10**) the specific bearing load  $p$  based on the specific load factor  $K = 80$  for PTFE composite is calculated using

$$p = K \frac{F}{C} = 80 \times \frac{0,8}{39} \approx 1,64 \text{ N/mm}^2$$

The sliding velocity is calculated using

$$v = 5,82 \times 10^{-7} d \beta f \\ = 5,82 \times 10^{-7} \times 20 \times 90 \times 10 = 0,01 \text{ m/s}$$

These values are within range I of the  $pv$  diagram for PTFE composite bearings (→ **diagram 1** on **page 10**). Furthermore

- the load factor  $c_1 = 1,3$  (→ **diagram 3**)
- the speed factor  $c_2 = 1$  (→ **diagram 4**)
- the temperature factor  $c_3 = 1$  (→ **diagram 5**)
- the surface roughness factor  $c_4 = 0,6$  (→ **diagram 6**)
- the factor for the type of load  $c_5 = 1,5$ , as the load is rotating
- exponent  $n = 1$ , for PTFE composite material.

- $pv$  value = 0,025, as the value of product  $p \times v = 1,64 \times 0,1 = 0,0164$  is less than the limiting value of 0,025 for PTFE composite material (→ **page 13**).

Using the material and bearing type factor  $K_M = 480$  for PTFE composite bushings, the basic rating life for the chosen bushings can be calculated from

$$G_h = c_1 c_2 c_3 c_4 c_5 \frac{K_M}{(pv)^n}$$

$$G_h = 1,3 \times 1 \times 1 \times 0,6 \times 1,5 \times \frac{480}{(0,025)^1}$$

$G_h \approx 22\,500$  operating hours

With a frequency  $f = 10 \text{ min}^{-1}$ , the working cycles amount to approximately 13,5 millions. The static load of 15 kN lies within the dynamic load rating of  $C = 39 \text{ kN}$  and far below the static load rating of  $C_0 = 120 \text{ kN}$ . Thus, the chosen bushings meet the requirements.

# Application of bearings

## Material and surface finish of counterfaces

The factors that are most important to consider when selecting the material and surface finish of the counterface (the surface on which the bearing slides) are the loading conditions (load, angle of oscillation, type of movement etc.) and the environmental influences.

Where there is a risk of corrosion, the counterface should be sufficiently resistant. Corrosion scars in the counterface and the by-product of corrosion (particulate contamination) increase the surface roughness and are abrasive and will accelerate wear. In these cases, the use of stainless steel or a surface treatment such as hard chromium, nickel plating or electrolytic oxidation should be considered.

For PTFE composite and POM composite plain bearing arrangements, soft carbon steels with a ground surface are usually adequate for the counterface. The surface roughness  $R_a$  (to EN ISO 4287:1998 and EN ISO 1302:2002) should not exceed 0,4  $\mu\text{m}$  for PTFE composite bearings and 0,8  $\mu\text{m}$  for POM composite bearings. The corresponding  $R_z$  values are 3 and 6  $\mu\text{m}$ , respectively. For more demanding applications the use of a hardened counterface is recommended. These should have a surface hardness of at least 50 HRC. Alternatively, hard chromium, nickel plating or some other form of surface treatment can be considered. In all cases  $R_a$  should not be greater than 0,3  $\mu\text{m}$  ( $R_z \leq 2 \mu\text{m}$ ). The better the surface finish, the better the running and wear properties ( $\rightarrow$  Surface roughness factor  $c_4$ , **diagram 6**, **page 12**).

## Shaft and housing tolerances

SKF recommends machining the seating in the housing bore to an H7 tolerance for metric PTFE composite and POM composite plain bushings (including flanged bushings), except for small bearings with a diameter up to 4 mm where H6 is recommended. If the shaft seating also meets the recommended tolerances, the clearance in the bearing arrangement will lie within the limits provided in **table 1** on **page 16** for PTFE composite plain bushings and in **table 2** on **page 17** for POM composite plain bushings, respectively.

The shaft and housing limits for inch bushings are provided in **table 3** on **page 19** for PTFE composite plain bushings and in **table 4** on **page 21** for POM composite plain bushings, together with the corresponding limits for the bushing bore diameter after mounting and the operating clearance.

The values quoted for operating clearance are valid at room temperature. If the operating temperature is higher than that, it is expected that the operating clearance of

- PTFE composite bushings will be reduced by 0,0016 mm
- POM composite bushings will be reduced by 0,005 mm

for every 20 °C temperature increase. The actual operating clearance can be increased or decreased within the recommended limits by matching shaft and housing bores having appropriate diameter values within the specified limits.

If in certain applications smooth running is required, or if the bearing is only lightly loaded, SKF recommends tolerancing the application so that maximum values for operating clearance are realized.

The recommended tolerances and guideline limits quoted in the tables are valid for steel and cast iron housings. Where light alloy housings are used, a greater degree of interference may be required because of the different thermal expansion characteristics of the housing and the bushing. There is otherwise a risk that the greater thermal expansion of the housing would no longer provide radial location for the bushing and that the operating clearance would be too large.

If it is not possible to adopt a greater interference fit, it might be possible to use an adhesive to retain the bushing. In special cases it may be necessary, by selecting a suitable tolerance for the shaft, to prevent an inadmissible increase in operating clearance.

Table 1

## Metric PTFE composite bushings – shaft and housing tolerances, operating clearance

Bushing dimensions			Diameter limits				Housing bore		Bore diameter of mounted bushing		Operating clearance	
Bore diameter	Outside diameter	Wall thickness		Shaft (f7 for d ≤ 75 mm) (h8 for d > 75 mm)		(H7)						
d	D	max	min	max	min	max	min	max	min	min	max	
mm				mm				µm				
3	4,5	0,750	0,730	3,000 (h6)	2,994 (h6)	4,508 (H6)	4,500 (H6)	3,048	3,000	0	54	
4	5,5	0,750	0,730	4,000 (h6)	3,992 (h6)	5,508 (H6)	5,500 (H6)	4,048	4,000	0	56	
5	7	1,005	0,980	4,990	4,978	7,015	7,000	5,055	4,990	0	77	
6	8	1,005	0,980	5,990	5,978	8,015	8,000	6,055	5,990	0	77	
7	9	1,005	0,980	6,987	6,972	9,015	9,000	7,055	6,990	3	83	
8	10	1,005	0,980	7,987	7,972	10,015	10,000	8,055	7,990	3	83	
10	12	1,005	0,980	9,987	9,972	12,018	12,000	10,058	9,990	3	86	
12	14	1,005	0,980	11,984	11,966	14,018	14,000	12,058	11,990	6	92	
13	15	1,005	0,980	12,984	12,966	15,018	15,000	13,058	12,990	6	92	
14	16	1,005	0,980	13,984	13,966	16,018	16,000	14,058	13,990	6	92	
15	17	1,005	0,980	14,984	14,966	17,018	17,000	15,058	14,990	6	92	
16	18	1,005	0,980	15,984	15,966	18,018	18,000	16,058	15,990	6	92	
17	19	1,005	0,980	16,984	16,966	19,021	19,000	17,061	16,990	6	95	
18	20	1,005	0,980	17,984	17,966	20,021	20,000	18,061	17,990	6	95	
20	23	1,505	1,475	19,980	19,959	23,021	23,000	20,071	19,990	10	112	
22	25	1,505	1,475	21,980	21,959	25,021	25,000	22,071	21,990	10	112	
24	27	1,505	1,475	23,980	23,959	27,021	27,000	24,071	23,990	10	112	
25	28	1,505	1,475	24,980	24,959	28,021	28,000	25,071	24,990	10	112	
28	32	2,005	1,970	27,980	27,959	32,025	32,000	28,085	27,990	10	126	
30	34	2,005	1,970	29,980	29,959	34,025	34,000	30,085	29,990	10	126	
32	36	2,005	1,970	31,975	31,950	36,025	36,000	32,085	31,990	15	135	
35	39	2,005	1,970	34,975	34,950	39,025	39,000	35,085	34,990	15	135	
37	40	1,505	1,475	36,975	36,950	40,025	40,000	37,075	36,990	15	125	
40	44	2,005	1,970	39,975	39,950	44,025	44,000	40,085	39,990	15	135	
45	50	2,505	2,460	44,975	44,950	50,025	50,000	45,105	44,990	15	155	
50	55	2,505	2,460	49,975	49,950	55,030	55,000	50,110	49,990	15	160	
55	60	2,505	2,460	54,970	54,940	60,030	60,000	55,110	54,990	20	170	
60	65	2,505	2,460	59,970	59,940	65,030	65,000	60,110	59,990	20	170	
65	70	2,505	2,460	64,970	64,940	70,030	70,000	65,110	64,990	20	170	
70	75	2,505	2,460	69,970	69,940	75,030	75,000	70,110	69,990	20	170	
75	80	2,505	2,460	74,970	74,940	80,030	80,000	75,110	74,990	20	170	
80	85	2,490	2,440	80,000	79,954	85,035	85,000	80,155	80,020	20	201	
85	90	2,490	2,440	85,000	84,946	90,035	90,000	85,155	85,020	20	209	
90	95	2,490	2,440	90,000	89,946	95,035	95,000	90,155	90,020	20	209	
95	100	2,490	2,440	95,000	94,946	100,035	100,000	95,155	95,020	20	209	
100	105	2,490	2,440	100,000	99,946	105,035	105,000	100,155	100,020	20	209	
105	110	2,490	2,440	105,000	104,946	110,035	110,000	105,155	105,020	20	209	
110	115	2,490	2,440	110,000	109,946	115,035	115,000	110,155	110,020	20	209	
115	120	2,490	2,440	115,000	114,946	120,035	120,000	115,155	115,020	20	209	
120	125	2,465	2,415	120,000	119,946	125,040	125,000	120,210	120,070	70	264	
125	130	2,465	2,415	125,000	124,937	130,040	130,000	125,210	125,070	70	273	
130	135	2,465	2,415	130,000	129,937	135,040	135,000	130,210	130,070	70	273	
135	140	2,465	2,415	135,000	134,937	140,040	140,000	135,210	135,070	70	273	
140	145	2,465	2,415	140,000	139,937	145,040	145,000	140,210	140,070	70	273	
150	155	2,465	2,415	150,000	149,937	155,040	155,000	150,210	150,070	70	273	



## Metric PTFE composite bushings – shaft and housing tolerances, operating clearance

Bushing dimensions		Wall thickness		Diameter limits Shaft (h8)		Housing bore (H7)		Bore diameter of mounted bushing		Operating clearance	
Bore diameter	Outside diameter	max	min	max	min	max	min	max	min	min	max
d	D										
mm				mm				µm			
<b>160</b>	165	2,465	2,415	160,000	159,937	165,040	165,000	160,210	160,070	70	273
<b>180</b>	185	2,465	2,415	180,000	179,937	185,046	185,000	180,216	180,070	70	279
<b>200</b>	205	2,465	2,415	200,000	199,928	205,046	205,000	200,216	200,070	70	288
<b>210</b>	215	2,465	2,415	210,000	209,928	215,046	215,000	210,216	210,070	70	288
<b>220</b>	225	2,465	2,415	220,000	219,928	225,046	225,000	220,216	220,070	70	288
<b>240</b>	245	2,465	2,415	240,000	239,928	245,046	245,000	240,216	240,070	70	288
<b>250</b>	255	2,465	2,415	250,000	249,928	255,052	255,000	250,222	250,070	70	294
<b>280</b>	285	2,465	2,415	280,000	279,919	285,052	285,000	280,222	280,070	70	303
<b>300</b>	305	2,465	2,415	300,000	299,919	305,052	305,000	300,222	300,070	70	303

Table 2

## Metric POM composite bushings – shaft and housing tolerances, operating clearance

Bushing dimensions		Wall thickness		Diameter limits Shaft (h8)		Housing bore (H7)		Bore diameter of mounted bushing		Operating clearance	
Bore diameter	Outside diameter	max	min	max	min	max	min	max	min	min	max
d	D										
mm				mm				µm			
<b>8</b>	10	0,980	0,955	8,000	7,978	10,015	10,000	8,105	8,040	40	127
<b>10</b>	12	0,980	0,955	10,000	9,978	12,018	12,000	10,108	10,040	40	130
<b>12</b>	14	0,980	0,955	12,000	11,973	14,018	14,000	12,108	12,040	40	135
<b>13</b>	15	0,980	0,955	13,000	12,973	15,018	15,000	13,108	13,040	40	135
<b>14</b>	16	0,980	0,955	14,000	13,973	16,018	16,000	14,108	14,040	40	135
<b>15</b>	17	0,980	0,955	15,000	14,973	17,018	17,000	15,108	15,040	40	135
<b>16</b>	18	0,980	0,955	16,000	15,973	18,018	18,000	16,108	16,040	40	135
<b>18</b>	20	0,980	0,955	18,000	17,973	20,021	20,000	18,111	18,040	40	138
<b>20</b>	23	1,475	1,445	20,000	19,967	23,021	23,000	20,131	20,050	50	164
<b>22</b>	25	1,475	1,445	22,000	21,967	25,021	25,000	22,131	22,050	50	164
<b>24</b>	27	1,475	1,445	24,000	23,967	27,021	27,000	24,131	24,050	50	164
<b>25</b>	28	1,475	1,445	25,000	24,967	28,021	28,000	25,131	25,050	50	164
<b>28</b>	32	1,970	1,935	28,000	27,967	32,025	32,000	28,155	28,060	60	188
<b>30</b>	34	1,970	1,935	30,000	29,967	34,025	34,000	30,155	30,060	60	188
<b>32</b>	36	1,970	1,935	32,000	31,961	36,025	36,000	32,155	32,060	60	194
<b>35</b>	39	1,970	1,935	35,000	34,961	39,025	39,000	35,155	35,060	60	194
<b>37</b>	40	1,475	1,445	37,000	36,961	40,025	40,000	37,135	37,050	50	174
<b>40</b>	44	1,970	1,935	40,000	39,961	44,025	44,000	40,155	40,060	60	194
<b>45</b>	50	2,460	2,415	45,000	44,961	50,025	50,000	45,195	45,080	80	234
<b>50</b>	55	2,460	2,415	50,000	49,961	55,030	55,000	50,200	50,080	80	239
<b>55</b>	60	2,460	2,415	55,000	54,954	60,030	60,000	55,200	55,080	80	246

## Metric POM composite bushings – shaft and housing tolerances, operating clearance

Bushing dimensions		Wall thickness		Diameter limits Shaft (h8)		Housing bore (H7)		Bore diameter of mounted bushing		Operating clearance	
Bore diameter	Outside diameter	max	min	max	min	max	min	max	min	min	max
d	D										
				mm				µm			
<b>60</b>	65	2,460	2,415	60,000	59,954	65,030	65,000	60,200	60,080	80	246
<b>65</b>	70	2,460	2,415	65,000	64,954	70,030	70,000	65,200	65,080	80	246
<b>70</b>	75	2,460	2,415	70,000	69,954	75,030	75,000	70,200	70,080	80	246
<b>75</b>	80	2,460	2,415	75,000	74,954	80,030	80,000	75,200	75,080	80	246
<b>80</b>	85	2,460	2,415	80,000	79,954	85,035	85,000	80,205	80,080	80	251
<b>85</b>	90	2,460	2,415	85,000	84,946	90,035	90,000	85,205	85,080	80	259
<b>90</b>	95	2,460	2,415	90,000	89,946	95,035	95,000	90,205	90,080	80	259
<b>95</b>	100	2,460	2,415	95,000	94,946	100,035	100,000	95,205	95,080	80	259
<b>100</b>	105	2,460	2,415	100,000	99,946	105,035	105,000	100,205	100,080	80	259
<b>105</b>	110	2,460	2,415	105,000	104,946	110,035	110,000	105,205	105,080	80	259
<b>110</b>	115	2,460	2,415	110,000	109,946	115,035	115,000	110,205	110,080	80	259
<b>115</b>	120	2,460	2,415	115,000	114,946	120,035	120,000	115,205	115,080	80	259
<b>120</b>	125	2,460	2,415	120,000	119,946	125,040	125,000	120,210	120,080	80	264
<b>125</b>	130	2,460	2,415	125,000	124,937	130,040	130,000	125,210	125,080	80	273
<b>130</b>	135	2,460	2,415	130,000	129,937	135,040	135,000	130,210	130,080	80	273
<b>135</b>	140	2,460	2,415	135,000	134,937	140,040	140,000	135,210	135,080	80	273
<b>140</b>	145	2,460	2,415	140,000	139,937	145,040	145,000	140,210	140,080	80	273
<b>150</b>	155	2,460	2,415	150,000	149,937	155,040	155,000	150,210	150,080	80	273
<b>160</b>	165	2,460	2,415	160,000	159,937	165,040	165,000	160,210	160,080	80	273
<b>180</b>	185	2,460	2,415	180,000	179,937	185,046	185,000	180,216	180,080	80	279
<b>190</b>	195	2,460	2,415	190,000	189,928	195,046	195,000	190,216	190,080	80	288
<b>200</b>	205	2,460	2,415	200,000	199,928	205,046	205,000	200,216	200,080	80	288
<b>210</b>	215	2,460	2,415	210,000	209,928	215,046	215,000	210,216	210,080	80	288
<b>220</b>	225	2,460	2,415	220,000	219,928	225,046	225,000	220,216	220,080	80	288
<b>250</b>	255	2,460	2,415	250,000	249,928	255,052	255,000	250,222	250,080	80	294
<b>280</b>	285	2,460	2,415	280,000	279,919	285,052	285,000	280,222	280,080	80	303
<b>300</b>	305	2,460	2,415	300,000	299,919	305,052	305,000	300,222	300,080	80	303

Table 3

## Inch PTFE composite bushings – shaft and housing tolerances, operating clearance

Bushing dimensions		Wall thickness		Diameter limits Shaft		Housing bore		Bore diameter of mounted bushing		Operating clearance	
Bore diameter	Outside diameter	max	min	max	min	max	min	max	min	min	max
d	D										
in/mm				in/mm				in/μm			
$\frac{1}{8}$ 3,175	$\frac{3}{16}$ 4,763	0,0315 0,800	0,0305 0,775	0,1243 3,157	0,1236 3,139	0,1878 4,770	0,1873 4,757	0,1268 3,221	0,1243 3,157	0,0000 0	0,0032 81
$\frac{3}{16}$ 4,763	$\frac{1}{4}$ 6,350	0,0315 0,800	0,0305 0,775	0,1865 4,737	0,1858 4,719	0,2503 6,358	0,2497 6,342	0,1893 4,808	0,1867 4,742	0,0002 5	0,0035 89
$\frac{1}{4}$ 6,35	$\frac{5}{16}$ 7,938	0,0315 0,800	0,0305 0,775	0,2490 6,325	0,2481 6,302	0,3128 7,945	0,3122 7,930	0,2518 6,396	0,2492 6,330	0,0002 5	0,0037 94
$\frac{5}{16}$ 7,938	$\frac{3}{8}$ 9,525	0,0315 0,800	0,0305 0,775	0,3115 7,912	0,3106 7,889	0,3753 9,533	0,3747 9,517	0,3143 7,983	0,3117 7,917	0,0002 5	0,0037 94
$\frac{3}{8}$ 9,525	$\frac{15}{32}$ 11,906	0,0471 1,196	0,0461 1,171	0,3740 9,500	0,3731 9,477	0,4691 11,915	0,4684 11,897	0,3769 9,573	0,3742 9,505	0,0002 5	0,0038 97
$\frac{7}{16}$ 11,113	$\frac{17}{32}$ 13,494	0,0471 1,196	0,0461 1,171	0,4365 11,087	0,4355 11,062	0,5316 13,503	0,5309 13,485	0,4394 11,161	0,4367 11,092	0,0002 5	0,0039 99
$\frac{1}{2}$ 12,7	$\frac{19}{32}$ 15,081	0,0471 1,196	0,0461 1,171	0,4990 12,675	0,4980 12,649	0,5941 15,090	0,5934 15,072	0,5019 12,748	0,4992 12,680	0,0002 5	0,0039 99
$\frac{9}{16}$ 14,288	$\frac{21}{32}$ 16,669	0,0471 1,196	0,0461 1,171	0,5615 14,262	0,5605 14,237	0,6566 16,678	0,6559 16,660	0,5644 14,336	0,5617 14,267	0,0002 5	0,0039 99
$\frac{5}{8}$ 15,875	$\frac{23}{32}$ 18,256	0,0471 1,196	0,0461 1,171	0,6240 15,850	0,6230 15,824	0,7192 18,268	0,7184 18,247	0,6270 15,926	0,6242 15,855	0,0002 5	0,0040 102
$\frac{11}{16}$ 17,463	$\frac{25}{32}$ 19,844	0,0471 1,196	0,0461 1,171	0,6865 17,437	0,6855 17,412	0,7817 19,855	0,7809 19,835	0,6895 17,513	0,6867 17,442	0,0002 5	0,0040 102
$\frac{3}{4}$ 19,05	$\frac{7}{8}$ 22,225	0,0627 1,593	0,0615 1,562	0,7491 19,027	0,7479 18,997	0,8755 22,238	0,8747 22,217	0,7525 19,114	0,7493 19,032	0,0002 5	0,0046 117
$\frac{7}{8}$ 22,225	1 25,4	0,0627 1,593	0,0615 1,562	0,8741 22,202	0,8729 22,172	1,0005 25,413	0,9997 25,392	0,8775 22,289	0,8743 22,207	0,0002 5	0,0046 117
1 25,4	$1\frac{1}{8}$ 28,575	0,0627 1,593	0,0615 1,562	0,9991 25,377	0,9979 25,347	1,1256 28,590	1,1246 28,565	1,0026 25,466	0,9992 25,380	0,0001 3	0,0047 119
$1\frac{1}{8}$ 28,575	$1\frac{9}{32}$ 32,544	0,0784 1,991	0,0770 1,956	1,1238 28,545	1,1226 28,514	1,2818 32,558	1,2808 32,532	1,1278 28,646	1,1240 28,550	0,0002 5	0,0052 132
$1\frac{1}{4}$ 31,75	$1\frac{13}{32}$ 35,719	0,0784 1,991	0,0770 1,956	1,2488 31,720	1,2472 31,679	1,4068 35,733	1,4058 35,707	1,2528 31,821	1,2490 31,725	0,0002 5	0,0056 142
$1\frac{3}{8}$ 34,925	$1\frac{17}{32}$ 38,894	0,0784 1,991	0,0770 1,956	1,3738 34,895	1,3722 34,854	1,5318 38,908	1,5308 38,882	1,3778 34,996	1,3740 34,900	0,0002 5	0,0056 142
$1\frac{1}{2}$ 38,1	$1\frac{21}{32}$ 42,069	0,0784 1,991	0,0770 1,956	1,4988 38,070	1,4972 38,029	1,6568 42,083	1,6558 42,057	1,5028 38,171	1,4990 38,075	0,0002 5	0,0056 142
$1\frac{5}{8}$ 41,275	$1\frac{25}{32}$ 45,244	0,0784 1,991	0,0770 1,956	1,6238 41,245	1,6222 41,204	1,7818 45,258	1,7808 45,232	1,6278 41,346	1,6240 41,250	0,0002 5	0,0056 142
$1\frac{3}{4}$ 44,45	$1\frac{15}{16}$ 49,213	0,0941 2,390	0,0923 2,344	1,7487 44,417	1,7471 44,376	1,9381 49,228	1,9371 49,202	1,7535 44,539	1,7489 44,422	0,0002 5	0,0064 163
$1\frac{7}{8}$ 47,625	$2\frac{1}{16}$ 52,388	0,0941 2,390	0,0923 2,344	1,8737 47,592	1,8721 47,551	2,0633 52,408	2,0621 52,377	1,8787 47,719	1,8739 47,597	0,0002 5	0,0066 168

## Inch PTFE composite bushings – shaft and housing tolerances, operating clearance

Bushing dimensions		Wall thickness		Diameter limits Shaft		Housing bore		Bore diameter of mounted bushing		Operating clearance	
Bore diameter	Outside diameter	max	min	max	min	max	min	max	min	min	max
d	D										
in/mm				in/mm				in/ $\mu$ m			
<b>2</b> 50,8	$2\frac{3}{16}$ 55,563	0,0941 2,390	0,0923 2,344	1,9987 50,767	1,9969 50,721	2,1883 55,583	2,1871 55,552	2,0037 50,894	1,9989 50,772	0,0002 5	0,0068 173
<b>2 <sup>1</sup>/<sub>4</sub></b> 57,15	$2\frac{7}{16}$ 61,913	0,0928 2,357	0,0902 2,291	2,2507 57,168	2,2489 57,122	2,4377 61,918	2,4365 61,887	2,2573 57,335	2,2509 57,173	0,0002 5	0,0084 213
<b>2 <sup>1</sup>/<sub>2</sub></b> 63,5	$2\frac{11}{16}$ 68,263	0,0928 2,357	0,0902 2,291	2,5011 63,528	2,4993 63,482	2,6881 68,278	2,6869 68,247	2,5077 63,696	2,5013 63,533	0,0002 5	0,0084 213
<b>2 <sup>3</sup>/<sub>4</sub></b> 69,85	$2\frac{15}{16}$ 74,613	0,0928 2,357	0,0902 2,291	2,7500 69,850	2,7482 69,804	2,9370 74,600	2,9358 74,569	2,7566 70,018	2,7502 69,855	0,0002 5	0,0084 213
<b>3</b> 76,2	$3\frac{3}{16}$ 80,963	0,0928 2,357	0,0902 2,291	3,0000 76,200	2,9982 76,154	3,1872 80,955	3,1858 80,919	3,0068 76,373	3,0002 76,205	0,0002 5	0,0086 218
<b>3 <sup>1</sup>/<sub>2</sub></b> 88,9	$3\frac{11}{16}$ 93,663	0,0928 2,357	0,0902 2,291	3,5000 88,900	3,4978 88,844	3,6872 93,655	3,6858 93,619	3,5068 89,073	3,5002 88,905	0,0002 5	0,0090 229
<b>4</b> 101,6	$4\frac{3}{16}$ 106,363	0,0928 2,357	0,0902 2,291	4,0000 101,600	3,9978 101,544	4,1872 106,355	4,1858 106,319	4,0068 101,773	4,0002 101,605	0,0002 5	0,0090 229
<b>5</b> 127	$5\frac{3}{16}$ 131,763	0,0928 2,357	0,0902 2,291	4,9986 126,964	4,9961 126,901	5,1860 131,724	5,1844 131,684	5,0056 127,142	4,9988 126,970	0,0002 5	0,0095 241
<b>6</b> 152,4	$6\frac{3}{16}$ 157,163	0,0928 2,357	0,0902 2,291	6,0000 152,400	5,9975 152,337	6,1874 157,160	6,1858 157,119	6,0070 152,578	6,0002 152,405	0,0002 5	0,0095 241
<b>7</b> 177,8	$7\frac{3}{16}$ 182,563	0,0928 2,357	0,0902 2,291	6,9954 177,683	6,9929 177,620	7,1830 182,448	7,1812 182,402	7,0026 177,866	6,9956 177,688	0,0002 5	0,0097 246

Table 4

## Inch POM composite bushings – shaft and housing tolerances, operating clearance

Bushing dimensions		Wall thickness		Diameter limits Shaft		Housing bore		Bore diameter of mounted bushing		Operating clearance	
Bore diameter	Outside diameter	max	min	max	min	max	min	max	min	min	max
d	D									in/μm	
in/mm				in/mm				in/μm			
$\frac{3}{8}$ 9,525	$\frac{15}{32}$ 11,906	0,051 1,295	0,050 1,270	0,3648 9,266	0,3639 9,243	0,4694 11,922	0,4687 11,904	0,3694 9,382	0,3667 9,314	0,0019 48	0,0055 139
$\frac{7}{16}$ 11,113	$\frac{17}{32}$ 13,494	0,051 1,295	0,050 1,270	0,4273 10,853	0,4263 10,828	0,5320 13,512	0,5313 13,494	0,4320 10,974	0,4293 10,904	0,0020 50	0,0057 142
$\frac{1}{2}$ 12,7	$\frac{19}{32}$ 15,081	0,051 1,295	0,050 1,270	0,4897 12,438	0,4887 12,413	0,5944 15,098	0,5937 15,080	0,4944 12,558	0,4917 12,490	0,0020 52	0,0057 145
$\frac{9}{16}$ 14,288	$\frac{21}{32}$ 16,669	0,051 1,295	0,050 1,270	0,5522 14,026	0,5512 14,001	0,6569 16,685	0,6562 16,667	0,5569 14,145	0,5543 14,078	0,0021 52	0,0057 144
$\frac{5}{8}$ 15,875	$\frac{23}{32}$ 18,256	0,051 1,295	0,050 1,270	0,6146 15,611	0,6136 15,585	0,7195 18,275	0,7187 18,255	0,6195 15,735	0,6167 15,665	0,0021 54	0,0059 150
$\frac{11}{16}$ 17,463	$\frac{25}{32}$ 19,844	0,051 1,295	0,050 1,270	0,6770 17,196	0,6760 17,170	0,7821 19,865	0,7812 19,842	0,6821 17,325	0,6793 17,254	0,0023 58	0,0061 155
$\frac{3}{4}$ 19,05	$\frac{7}{8}$ 22,225	0,0669 1,699	0,0657 1,669	0,7390 18,771	0,7378 18,740	0,8758 22,245	0,8750 22,225	0,7444 18,907	0,7412 18,827	0,0022 56	0,0066 167
$\frac{7}{8}$ 22,225	1 25,4	0,0669 1,699	0,0657 1,669	0,8639 21,943	0,8627 21,913	1,0008 25,421	1,0000 25,400	0,8694 22,083	0,8662 22,002	0,0023 59	0,0067 170
1 25,4	1 $\frac{1}{8}$ 28,575	0,0669 1,699	0,0657 1,669	0,9888 25,116	0,9876 25,085	1,1258 28,595	1,1250 28,575	0,9944 25,258	0,9912 25,177	0,0024 61	0,0068 173
1 $\frac{1}{8}$ 28,575	1 $\frac{9}{32}$ 32,544	0,0824 2,093	0,0810 2,057	1,1138 28,291	1,1126 28,260	1,2822 32,569	1,2813 32,544	1,1203 28,455	1,1165 28,358	0,0027 67	0,0077 195
1 $\frac{1}{4}$ 31,75	1 $\frac{13}{32}$ 35,719	0,0824 2,093	0,0810 2,057	1,2387 31,463	1,2371 31,422	1,4072 35,743	1,4063 35,719	1,2453 31,639	1,2415 31,533	0,0028 70	0,0082 208
1 $\frac{3}{8}$ 34,925	1 $\frac{17}{32}$ 38,894	0,0824 2,093	0,0810 2,057	1,3635 34,633	1,3619 34,592	1,5322 38,919	1,5313 38,894	1,3703 34,805	1,3664 34,708	0,0029 75	0,0084 213
1 $\frac{1}{2}$ 38,1	1 $\frac{21}{32}$ 42,069	0,0824 2,093	0,0810 2,057	1,4884 37,805	1,4868 37,765	1,6572 42,097	1,6562 42,069	1,4953 37,980	1,4915 37,883	0,0031 78	0,0085 215
1 $\frac{5}{8}$ 41,275	1 $\frac{25}{32}$ 45,244	0,0824 2,093	0,0810 2,057	1,6133 40,978	1,6117 40,937	1,7822 45,269	1,7813 45,244	1,6203 41,155	1,6165 41,058	0,0032 80	0,0086 218
1 $\frac{3}{4}$ 44,45	1 $\frac{15}{16}$ 49,213	0,098 2,489	0,0962 2,443	1,7383 44,153	1,7367 44,112	1,9385 49,238	1,9375 49,213	1,7461 44,352	1,7415 44,235	0,0032 82	0,0094 240
1 $\frac{7}{8}$ 47,625	2 $\frac{1}{16}$ 52,388	0,098 2,489	0,0962 2,443	1,8632 47,325	1,8616 47,285	2,0637 52,418	2,0625 52,388	1,8713 47,532	1,8665 47,410	0,0033 85	0,0097 247
2 50,8	2 $\frac{3}{16}$ 55,563	0,098 2,489	0,0962 2,443	1,9881 50,498	1,9863 50,452	2,1887 55,593	2,1875 55,563	1,9963 50,707	1,9915 50,585	0,0034 87	0,0100 255
2 $\frac{1}{4}$ 57,15	2 $\frac{7}{16}$ 61,913	0,098 2,489	0,0962 2,443	2,2378 56,840	2,2360 56,794	2,4387 61,943	2,4375 61,913	2,2463 57,057	2,2415 56,935	0,0037 95	0,0103 263
2 $\frac{1}{2}$ 63,5	2 $\frac{11}{16}$ 68,263	0,098 2,489	0,0962 2,443	2,4875 63,183	2,4857 63,137	2,6887 68,293	2,6875 68,263	2,4963 63,407	2,4915 63,285	0,0040 102	0,0106 270
2 $\frac{3}{4}$ 69,85	2 $\frac{15}{16}$ 74,613	0,0991 2,517	0,0965 2,451	2,7351 69,472	2,7333 69,426	2,9387 74,643	2,9375 74,613	2,7457 69,741	2,7393 69,579	0,0042 107	0,0124 315

## Inch POM composite bushings – shaft and housing tolerances, operating clearance

Bushing dimensions		Wall thickness		Diameter limits Shaft		Housing bore		Bore diameter of mounted bushing		Operating clearance	
Bore diameter	Outside diameter	max	min	max	min	max	min	max	min	min	max
d	D										
in/mm				in/mm						in/ $\mu$ m	
<b>3</b>	$3 \frac{3}{16}$	0,0991	0,0965	2,9849	2,9831	3,1889	3,1875	2,9959	2,9893	0,0044	0,0128
76,2	80,963	2,517	2,451	75,817	75,771	80,998	80,963	76,096	75,929	112	325
<b>3 1/2</b>	$3 \frac{11}{16}$	0,0991	0,0965	3,4844	3,4822	3,6889	3,6875	3,4959	3,4893	0,0049	0,0137
88,9	93,663	2,517	2,451	88,504	88,448	93,698	93,663	88,796	88,629	125	348
<b>4</b>	$4 \frac{3}{16}$	0,0991	0,0965	3,9839	3,9817	4,1889	4,1875	3,9959	3,9893	0,0054	0,0142
101,6	106,363	2,517	2,451	101,191	101,135	106,398	106,363	101,496	101,329	138	361

# Design of associated components

## Straight bushings

To prevent the sliding surface from becoming stepped, the sliding surface of the shaft, i.e. the counterface, should always be wider than the actual bushing width – particularly where axial displacement of the shaft relative to the housing may occur as a result of axial expansion.

To facilitate mounting, shaft ends and housing bores should have a lead-in chamfer with an angle of 10 to 15° (→ fig. 1). These chamfers will make it easier to press the bushings into the housing bore and to insert the shaft into the bushing bore, without the risk of damaging the sliding surface.

The housing shoulders intended to locate the bushing axially should have a diameter that is equal to or greater than  $d + 0,8$  mm.

When PTFE composite bushings operate without a lubricant it is especially important to accurately align all bearing positions. If misalignment between the positions cannot be avoided, take steps during the design stage to prevent inadmissibly high edge stresses from occurring. For example, the housing bore seating can be relieved on both sides, or a wider bushing can be used so that it extends beyond the housing bore seating on both sides (→ fig. 2).

In case of misalignment have to be compensated for and the operating conditions permit the use of POM composite, then the bushings of this material should be chosen. The covering layer of this material can be machined to a minimum degree after the bushing has been mounted in a housing bore.

## Flanged bushings and thrust washers

For shafts that need radial support and axial location, flanged bushings or a combination bushing-thrust washer (→ fig. 3) can be used depending on the magnitude of the axial load. Flanged bushings or thrust washers are advantageous even if axial loads are light and a surface is not adequate to accommodate the thrust, either because the material or its finish is unsuitable.

Note that the counterface should completely cover the sliding surface of the thrust washer and the flange of a flanged bushing (→ fig. 4). For bearing arrangements where flanged bushings are used, the transition from housing bore to abutment should be chamfered so that it does not contact the bushing where it meets the flange (→ fig. 5).

A thrust washer is generally located in a housing recess (→ fig. 3) and secured by a dowel pin or grub screw to prevent it from rotating. The appropriate dimensions for this type of location are provided in the product tables. If for some reason, a recess cannot be

provided in the housing, the thrust washer can be attached to the housing by two pins or screws (→ fig. 6) or by gluing. The heads of the pins or screws must be recessed to at least 0,3 mm below the sliding surface and the entire surface of the thrust washer must be supported.

Lead-in chamfers for housing bores and shaft ends

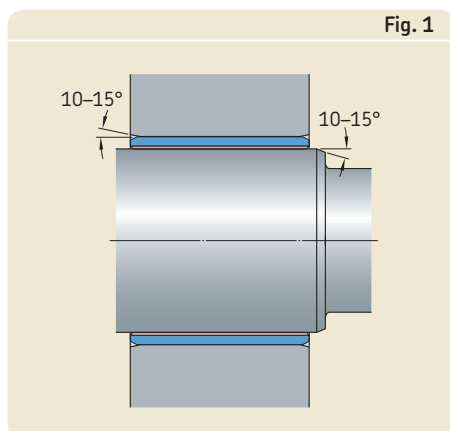

Bushing extending beyond the bearing seating in the housing on both sides to prevent inadmissibly high edge stresses

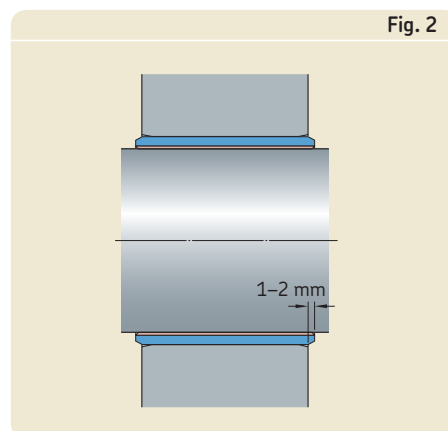

Combination of a bushing and thrust washer

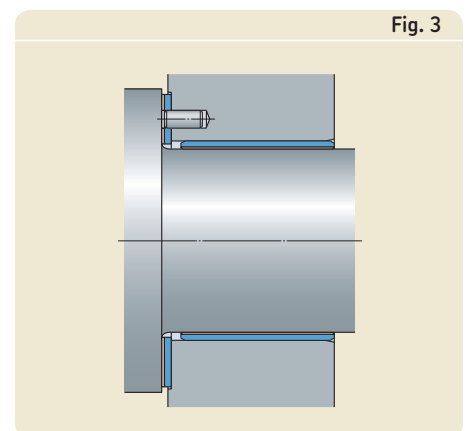

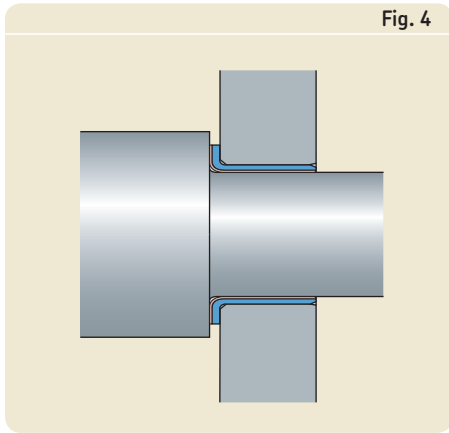

Fig. 4

The mating surface should cover the entire surface of the flange

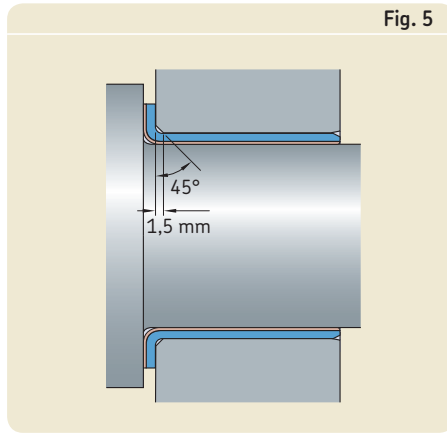

Fig. 5

The transition between housing bore and support surface must be sufficiently large

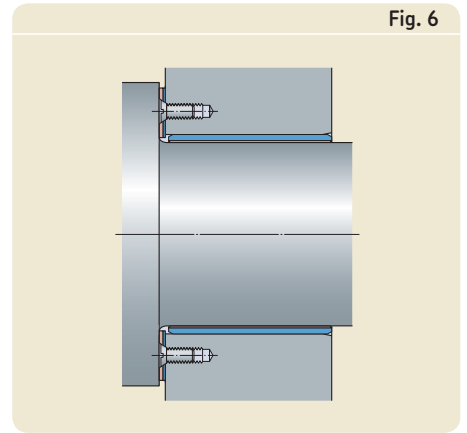

Fig. 6

Thrust washer secured by two screws

## Seals

Seals can decisively influence the service life of composite plain bearings. When selecting seals consider, for example, the design, the available space and the justifiable expense.

Composite plain bearings, particularly the POM composite, are able to embed contaminant particles and are thus relatively insensitive to contamination. They generally require no special protection against normal airborne dirt. If, however, the bearing position is subjected to heavier contamination it should be sealed from the outside. Simple and efficient sealing can be obtained if adjacent components can also serve as seals (→ fig. 7).

Radial shaft seals with a low cross section, e.g. seals in the G series, as used for needle roller bearings, can provide adequate protec-

tion for composite plain bearings in most cases (→ fig. 8). If the demands placed on the sealing arrangement are high, it may be necessary to resort to special seals of rubber, plastic or similar materials (→ fig. 9).

In highly contaminated environments, particularly where sand or clay is present, rubber or plastic seals tend to have a very short service life. Under these conditions, a good seal can be achieved by periodically relubricating the bushing.

Adjacent components serve as seals

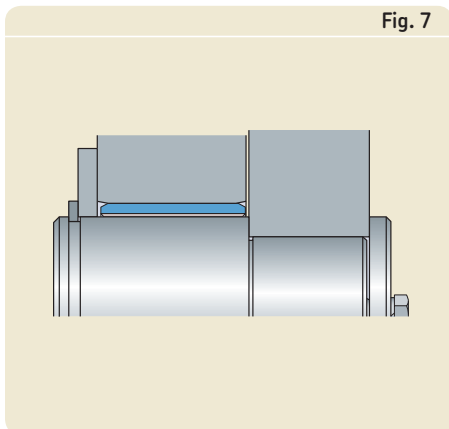

Fig. 7

A shaft seal with low cross sectional height can be used

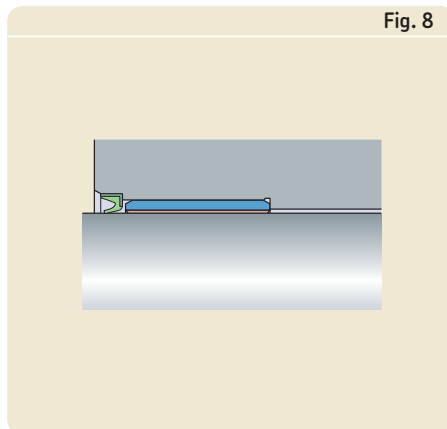

Fig. 8

Sealing with a wiper-scraper seal of nitrile rubber

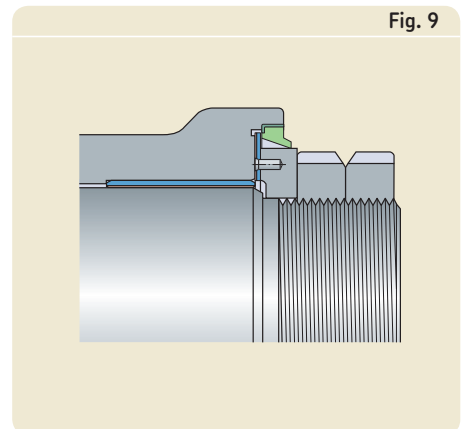
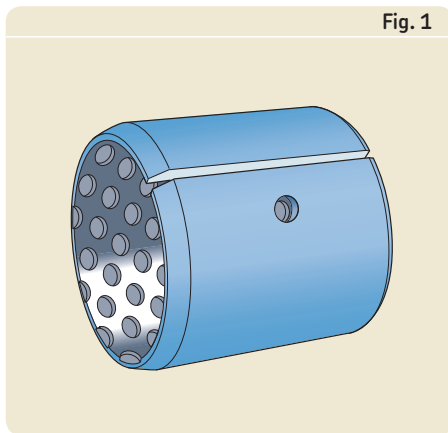

Fig. 9



# Lubrication



*POM composite straight bushing with a lubrication hole*

## PTFE composite bearings

PTFE composite plain bearings have good dry sliding characteristics and do not require lubrication. However, the use of other lubricants not normally associated with bearings such as water, kerosene or paraffin, can be used.

A lubricant helps to dissipate heat from the bearing position as it forms a hydrodynamic lubricating film to reduce wear and extend bearing service life. However, relubrication is also very important.

If a bearing is greased during mounting to enhance sealing or to protect the counterface against corrosion, bearing service life will be extended, provided the bearing is relubricated periodically. If the bearing is not relubricated, the grease will form a paste-like mixture with the wear particles produced during run-in. This paste will significantly accelerate bearing wear.

## POM composite bearings

POM composite plain bearings require an initial application of grease during mounting. Relubrication is not required but the presence or constant supply of a lubricating fluid or grease can extend bearing service life considerably.

For this reason POM composite bushings with a bore diameter  $\geq 10$  mm and a width  $\geq 12$  mm are available as standard with a lubrication hole ( $\rightarrow$  **fig. 1**). The hole dimensions and position are in accordance with ISO 3547-3:2006.

Age-resistant greases with a lithium thickener are preferred for operating temperatures up to 80 °C, while at higher temperatures, silicone greases should be used. Greases containing solid lubricants such as molybdenum disulphide are totally unsuitable.

# Mounting

Skill and care in mounting are prerequisites for long bearing service life. In addition, cleanliness, and understanding the causes of premature bearing failure can help too.

Check that the counterface (shaft seating) and other components like the housing are clean, deburred and that they do not contain any abrasive particles. Check also the shaft for sharp edges, burrs or surface defects, which could damage the sliding surface of the bushings as they are mounted. Once all the components have been cleaned and checked, the bushing is ready to be installed.

To install smaller PTFE or POM bushings, with or without a flange, a mounting dolly should be used (→ **fig. 1**). To do this, place an O-ring on the dolly to keep the bushing in position. Then drive the bushing into place with a mechanical or hydraulic press or by

tapping the dolly lightly with a hammer. To facilitate the mounting of small bushings, apply a light coating of oil or grease to the housing bore. For larger bushings, SKF recommends using a mounting ring (→ **fig. 2**) because it aligns and centres the bushing while it is being pressed into place. When mounting larger bushings, use a solid lubricant paste, like the SKF anti-fretting agent LGAF 3E, on the seating to reduce the risk of fretting corrosion and also to reduce the force required for mounting.

Composite straight bushings and flanged bushings which are to be heavily loaded in operation should be mounted so that the butt joint is at 90° to the loaded zone during operation (→ **fig. 3**), otherwise service life will be reduced. When mounting, thrust washers

should be positioned so that the steel backing abuts the housing wall.

If composite plain bearings are to be located in a housing using an adhesive, the adhesive should be suitable for the expected operating temperature and should have suitable expansion, ageing resistance, strength and curing properties. If no operational experience is available, SKF recommends contacting an adhesive manufacturer for advice. When applying an adhesive, care should be taken so that no adhesive reaches the sliding surface.

**Mounting with a mandrel**

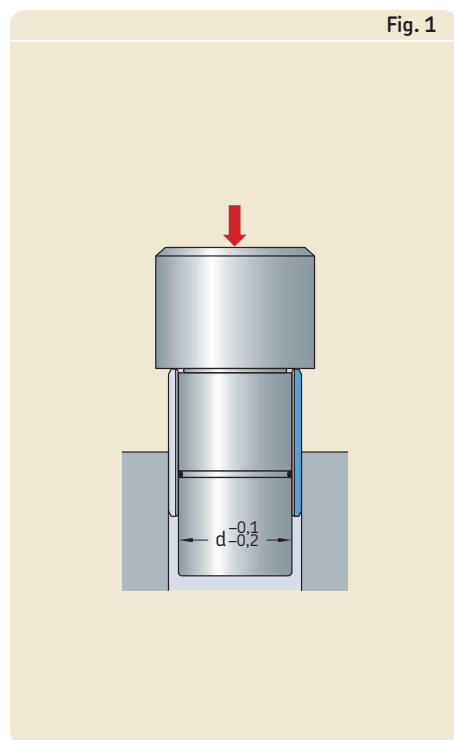

**Mounting with a mandrel and mounting ring**

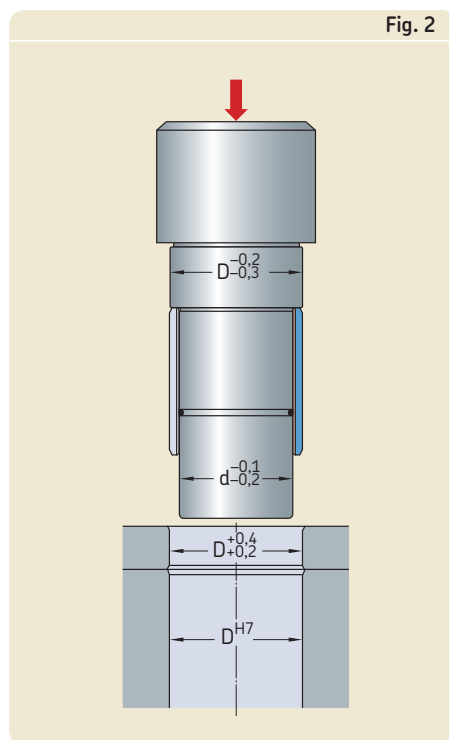

*The main direction of the load must be at 90° to the plane of the butt joint*

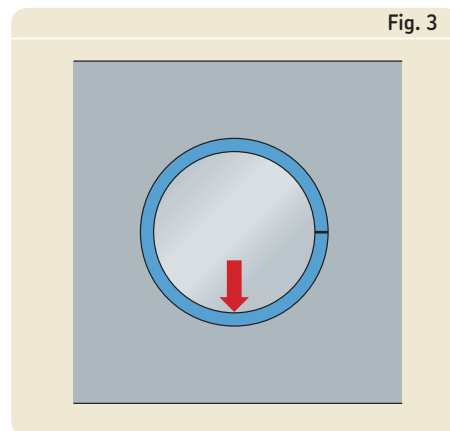

# Bearing data – general

## Dimensions

The dimensions for metric straight bushings are in accordance, with few exceptions, with those specified in ISO 3547-1:2006.

The dimensions of inch bushings, flanged bushings and thrust washers have not been standardized.

## Tolerances

**Straight bushings:** The tolerances for the outside diameter of metric straight bushings correspond to ISO 3547-1:2006. To check the values, use the procedure provided in ISO 3547-2:2006.

**Flanged bushings:** When mounted, the tolerances are a uniform  $\pm 0,5$  mm for the flange diameter  $D_1$  and  $+0,05/-0,20$  mm for the width  $B_1$ .

**Thrust washers:** The tolerances for the diameters are provided in the product table. The tolerances for the height are

- $0/-0,05$  mm for PTFE composite washers
- $0/-0,10$  mm for POM composite washers.

**Strips:** The tolerances for the height are

- $0/-0,05$  mm for PTFE composite strips
- $0/-0,10$  mm for POM composite strips.

**Chamfer dimensions:** The minimum values are provided in the product tables. Chamfer dimensions and tolerances for metric sizes are provided in **table 1**.

## Operating clearances

The operating clearance of a bushing depends on its selected shaft and housing tolerances. Guideline values for metric bushings are provided in **tables 1** and **2**, on **pages 16 to 18**, and for inch bushings in **tables 3** and **4** on **pages 19 to 22**.

Excessive clearance may have a negative influence on the service life of PTFE composite bushings if they are not lubricated.

## Permissible operating temperature range

PTFE composite plain bearings can be used at temperatures between  $-200$  and  $+250$  °C.

The operating temperature range for POM composite bearings is  $-40$  to  $+110$  °C, although brief periods of operation at  $+130$  °C are permissible.

The service life of SKF composite plain bearings will be reduced if operating temperatures exceed the limit values. This decrease in service life can be taken into account when calculating the basic rating life by the temperature factor  $c_3$  ( $\rightarrow$  **diagram 5**, **page 12**).

## Product designations

The basic designation of SKF composite plain bearings consists of

- a prefix, a combination of three or four letters, which indicates the bearing type,
- a combination of 4 to 9 figures, identifying the size, and
- suffixes, identifying material and design variants.

The prefix PCM identifies a metric and the prefix PCZ identifies an inch composite straight bushing. Supplementary letters, following these combinations identify other bearing types and have the following meaning:

- F: flanged bushing,
- S: strip,
- W: thrust washer.

In the case of metric bushings, flanged bushings and thrust washers, the combination of 6 to 9 figures identify the bore diameter (d), the outside diameter (D) and the width (B) or height (H). For example, a POM composite bushing with  $d = 8$  mm,  $D = 10$  mm and  $B = 8$  mm is designated PCM 081008 M. Small bushings carrying the additional suffix VB055 are an exception to this: the outside diameter is 0,5 mm larger than indicated in the designation.

In the case of composite strips, the combination of figures identifies width, length and height.

The designations for inch bushings are similar but in this case the figures only identify the bore diameter (d) and the width (B) in  $1/16$ ths of an inch. For example a PTFE composite bushing with bore diameter  $d = 3/4 = 12/16$  inch and  $B = 1/2 = 8/16$  inch is designated PCZ 1208 E.

The suffixes used to identify the material variant are listed below

- E: layer of PTFE with molybdenum disulfide additives
- M: layer of POM composite.

**Table 1**

### Chamfer dimensions and tolerances (metric sizes)

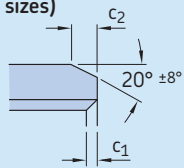

### Wall thickness

	$c_{1min}$	$c_{1max}$	$c_2$
mm			mm
0.75	0.1	0.4	0.5 +/- 0.3
1	0.1	0.6	0.6 +/- 0.4
1.5	0.1	0.7	0.6 +/- 0.4
2	0.1	0.7	1.2 +/- 0.4
2.5	0.2	1.0	1.8 +/- 0.6

# Metric composite straight bushings

d 3 – 15 mm

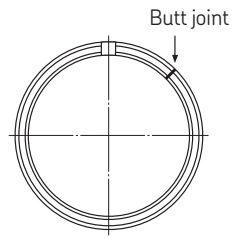
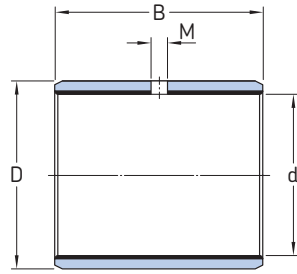
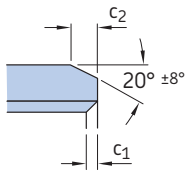

Dimensions						Basic load ratings		Mass	Designations	POM composite
d	D	B	M <sup>1)</sup>	c <sub>1</sub> <sup>1)</sup> min	c <sub>2</sub> <sup>1)</sup> min	dynamic C	static C <sub>0</sub>	g	Straight bushing of PTFE composite	
mm						kN			–	
3	4,5	3	–	0,1	0,2	0,72	2,24	0,2	PCM 030403 E/VB055	–
	4,5	6	–	0,1	0,2	1,43	4,5	0,4	PCM 030406 E/VB055	–
4	5,5	3	–	0,1	0,2	0,965	3	0,2	PCM 040503 E/VB055	–
	5,5	4	–	0,1	0,2	1,27	4	0,3	PCM 040504 E/VB055	–
	5,5	6	–	0,1	0,2	1,93	6	0,6	PCM 040506 E/VB055	–
	5,5	10	–	0,1	0,2	3,2	10	0,8	PCM 040510 E/VB055	–
5	7	5	–	0,1	0,2	2	6,2	0,7	PCM 050705 E	–
	7	8	–	0,1	0,2	3,2	10	1,1	PCM 050708 E	–
	7	10	–	0,1	0,2	4	12,5	1,4	PCM 050710 E	–
6	8	6	–	0,1	0,2	2,9	9	1,0	PCM 060806 E	–
	8	8	–	0,1	0,2	3,8	12	1,3	PCM 060808 E	–
	8	10	–	0,1	0,2	4,8	15	1,6	PCM 060810 E	–
7	9	10	–	0,1	0,2	5,6	17,6	1,8	PCM 070910 E	–
8	10	6	–	0,1	0,2	3,8	12	1,2	PCM 081006 E	–
	10	8	–	0,1	0,2	5,1	16	1,7	PCM 081008 E	–
	10	8	–	0,1	0,2	7,65	16	1,3	–	PCM 081008 M
	10	10	–	0,1	0,2	6,4	20	2,1	PCM 081010 E	–
	10	10	–	0,1	0,2	9,65	20	1,6	–	PCM 081010 M
	10	12	–	0,1	0,2	7,65	24	2,5	PCM 081012 E	–
	10	12	–	0,1	0,2	11,6	24	1,9	–	PCM 081012 M

<sup>1)</sup> If no values are given for M, the bushing has no lubrication hole.

Dimensions						Basic load ratings		Mass	Designations		
d	D	B	M <sup>1)</sup> min	c <sub>1</sub> min	c <sub>2</sub> min	C	C <sub>0</sub>		Straight bushing of PTFE composite	POM composite	
mm						kN		g	–		
10	12	8	–	0,1	0,2	6,4	20	2,0	PCM 101208 E	–	
	12	10	–	0,1	0,2	8	25	2,5	PCM 101210 E	–	
	12	10	3	0,1	0,2	12	25	1,9	–	PCM 101210 M	
	12	12	–	0,1	0,2	9,65	30	3,0	PCM 101212 E	–	
	12	12	3	0,1	0,2	14,3	30	2,3	–	PCM 101212 M	
	12	15	–	0,1	0,2	12	37,5	3,8	PCM 101215 E	–	
	12	15	3	0,1	0,2	18	37,5	2,9	–	PCM 101215 M	
	12	20	–	0,1	0,2	16	50	5,1	PCM 101220 E	–	
	12	20	3	0,1	0,2	24	50	3,9	–	PCM 101220 M	
	12	14	8	–	0,1	0,2	7,65	24	2,4	PCM 121408 E	–
		14	10	–	0,1	0,2	9,65	30	3,0	PCM 121410 E	–
		14	10	–	0,1	0,2	14,3	30	2,3	–	PCM 121410 M
		14	12	–	0,1	0,2	11,6	36	3,6	PCM 121412 E	–
		14	12	3	0,1	0,2	17,3	36	2,8	–	PCM 121412 M
14		15	–	0,1	0,2	14,3	45	4,5	PCM 121415 E	–	
14		15	3	0,1	0,2	21,6	45	3,5	–	PCM 121415 M	
14		20	–	0,1	0,2	19,3	60	6,0	PCM 121420 E	–	
14		20	3	0,1	0,2	29	60	4,6	–	PCM 121420 M	
14		25	–	0,1	0,2	24	75	7,6	PCM 121425 E	–	
14		25	3	0,1	0,2	36	75	5,8	–	PCM 121425 M	
13		15	10	–	0,1	0,2	10,4	32,5	3,2	PCM 131510 E	–
		15	10	–	0,1	0,2	15,6	32,5	2,4	–	PCM 131510 M
		15	20	–	0,1	0,2	20,8	65,5	6,3	PCM 131520 E	–
14	16	10	–	0,1	0,2	11,2	34,5	3,5	PCM 141610 E	–	
	16	12	–	0,1	0,2	13,4	41,5	4,2	PCM 141612 E	–	
	16	15	–	0,1	0,2	16,6	52	5,2	PCM 141615 E	–	
	16	15	3	0,1	0,2	25	52	4,0	–	PCM 141615 M	
	16	20	–	0,1	0,2	22,4	70	7,0	PCM 141620 E	–	
	16	20	3	0,1	0,2	33,5	70	5,3	–	PCM 141620 M	
	16	25	–	0,1	0,2	28	88	8,7	PCM 141625 E	–	
	16	25	3	0,1	0,2	41,5	88	6,6	–	PCM 141625 M	
	15	17	10	–	0,1	0,2	12	37,5	3,7	PCM 151710 E	–
		17	10	–	0,1	0,2	18	37,5	2,8	–	PCM 151710 M
17		12	–	0,1	0,2	14,3	45	4,4	PCM 151712 E	–	
17		12	3	0,1	0,2	21,6	45	3,4	–	PCM 151712 M	
17		15	–	0,1	0,2	18	56	5,6	PCM 151715 E	–	
17		15	3	0,1	0,2	27	56	4,3	–	PCM 151715 M	
17		20	–	0,1	0,2	24	75	7,4	PCM 151720 E	–	
17		25	–	0,1	0,2	30	93	9,3	PCM 151725 E	–	

<sup>1)</sup> If no values are given for M, the bushing has no lubrication hole.

# Metric composite straight bushings

d 16 – 30 mm

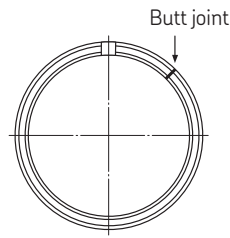
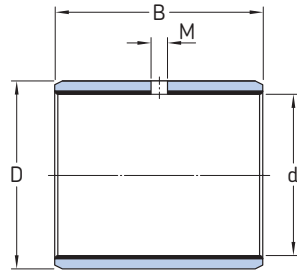
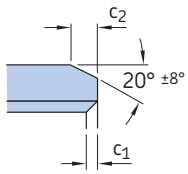

Dimensions						Basic load ratings		Mass	Designations	POM composite
d	D	B	M <sup>1)</sup>	c <sub>1</sub> min	c <sub>2</sub> min	dynamic	static		Straight bushing of PTFE composite	
mm						kN		g	–	
16	18	10	–	0,1	0,2	12,9	40	3,9	PCM 161810 E	–
	18	12	–	0,1	0,2	15,3	48	4,7	PCM 161812 E	–
	18	15	–	0,1	0,2	19,3	60	5,9	PCM 161815 E	–
	18	15	3	0,1	0,2	29	60	4,5	–	PCM 161815 M
	18	20	–	0,1	0,2	25,5	80	7,9	PCM 161820 E	–
	18	20	3	0,1	0,2	38	80	6,0	–	PCM 161820 M
	18	25	–	0,1	0,2	32	100	9,9	PCM 161825 E	–
	18	25	3	0,1	0,2	48	100	7,5	–	PCM 161825 M
17	19	20	–	0,1	0,2	27	85	8,3	PCM 171920 E	–
18	20	15	–	0,1	0,2	21,6	67	6,6	PCM 182015 E	–
	20	15	3	0,1	0,2	32,5	67	5,0	–	PCM 182015 M
	20	20	–	0,1	0,2	29	90	8,8	PCM 182020 E	–
	20	20	3	0,1	0,2	43	90	6,7	–	PCM 182020 M
	20	25	–	0,1	0,2	36	112	11	PCM 182025 E	–
	20	25	3	0,1	0,2	54	112	8,4	–	PCM 182025 M
20	23	10	–	0,1	0,2	14,6	45,5	7,4	PCM 202310 E	–
	23	10	–	0,1	0,2	22	45,5	6,4	–	PCM 202310 M
	23	15	–	0,1	0,2	22,8	71	11	PCM 202315 E	–
	23	15	3	0,1	0,2	34	71	9,7	–	PCM 202315 M
	23	20	–	0,1	0,2	30,5	96,5	15	PCM 202320 E	–
	23	20	3	0,1	0,2	46,5	96,5	13	–	PCM 202320 M
	23	25	–	0,1	0,2	39	120	19	PCM 202325 E	–
	23	25	3	0,1	0,2	58,5	120	16	–	PCM 202325 M
	23	30	–	0,1	0,2	46,5	146	23	PCM 202330 E	–
	23	30	3	0,1	0,2	69,5	146	19	–	PCM 202330 M

<sup>1)</sup> If no values are given for M, the bushing has no lubrication hole.

Dimensions						Basic load ratings		Mass	Designations	
d	D	B	M <sup>1)</sup>	c <sub>1</sub> min	c <sub>2</sub> min	C	C <sub>0</sub>		Straight bushing of PTFE composite	POM composite
mm						kN		g	–	
22	25	15	–	0,1	0,2	25	78	12	PCM 222515 E	–
	25	15	3	0,1	0,2	37,5	78	11	–	PCM 222515 M
	25	20	–	0,1	0,2	34	106	16	PCM 222520 E	–
	25	20	3	0,1	0,2	51	106	14	–	PCM 222520 M
	25	25	–	0,1	0,2	42,5	134	21	PCM 222525 E	–
	25	25	3	0,1	0,2	64	134	18	–	PCM 222525 M
	25	30	–	0,1	0,2	51	160	25	PCM 222530 E	–
	25	30	3	0,1	0,2	76,5	160	21	–	PCM 222530 M
24	27	15	–	0,1	0,2	27,5	85	13	PCM 242715 E	–
	27	20	–	0,1	0,2	36,5	116	18	PCM 242720 E	–
	27	20	4	0,1	0,2	55	116	15	–	PCM 242720 M
	27	25	–	0,1	0,2	46,5	146	22	PCM 242725 E	–
	27	30	–	0,1	0,2	56	176	26	PCM 242730 E	–
	28	15	–	0,1	0,2	28,5	88	14	PCM 252815 E	–
25	28	15	4	0,1	0,2	42,5	88	12	–	PCM 252815 M
	28	20	–	0,1	0,2	38	120	18	PCM 252820 E	–
	28	20	4	0,1	0,2	57	120	16	–	PCM 252820 M
	28	25	–	0,1	0,2	48	150	23	PCM 252825 E	–
	28	25	4	0,1	0,2	72	150	20	–	PCM 252825 M
	28	30	–	0,1	0,2	58,5	183	28	PCM 252830 E	–
	28	30	4	0,1	0,2	88	183	24	–	PCM 252830 M
	28	40	–	0,1	0,2	78	245	37	PCM 252840 E	–
	28	50	–	0,1	0,2	98	310	47	PCM 252850 E	–
	28	50	4	0,1	0,2	146	310	40	–	PCM 252850 M
28	32	20	–	0,1	0,8	43	134	28	PCM 283220 E	–
	32	20	4	0,1	0,8	64	134	25	–	PCM 283220 M
	32	25	–	0,1	0,8	54	170	35	PCM 283225 E	–
	32	25	4	0,1	0,8	81,5	170	32	–	PCM 283225 M
	32	30	–	0,1	0,8	65,5	204	42	PCM 283230 E	–
	32	30	4	0,1	0,8	98	204	38	–	PCM 283230 M
30	34	15	–	0,1	0,8	34	106	22	PCM 303415 E	–
	34	20	–	0,1	0,8	46,5	143	30	PCM 303420 E	–
	34	20	4	0,1	0,8	69,5	143	27	–	PCM 303420 M
	34	25	–	0,1	0,8	58,5	180	37	PCM 303425 E	–
	34	30	–	0,1	0,8	69,5	220	45	PCM 303430 E	–
	34	30	4	0,1	0,8	106	220	41	–	PCM 303430 M
	34	40	–	0,1	0,8	95	300	60	PCM 303440 E	–
	34	40	4	0,1	0,8	140	300	54	–	PCM 303440 M

<sup>1)</sup> If no values are given for M, the bushing has no lubrication hole.

# Metric composite straight bushings

d 32 – 65 mm

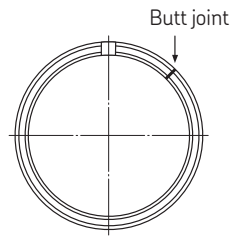
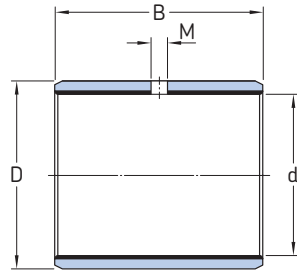
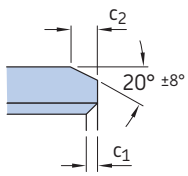

Dimensions						Basic load ratings		Mass	Designations	POM composite
d	D	B	M <sup>1)</sup>	c <sub>1</sub> min	c <sub>2</sub> min	dynamic C	static C <sub>0</sub>	g	Straight bushing of PTFE composite	
mm						kN			–	
32	36	20	–	0,1	0,8	49	153	31	PCM 323620 E	–
	36	20	4	0,1	0,8	73,5	153	29	–	PCM 323620 M
	36	30	–	0,1	0,8	75	232	48	PCM 323630 E	–
	36	30	4	0,1	0,8	112	232	43	–	PCM 323630 M
	36	40	–	0,1	0,8	100	315	64	PCM 323640 E	–
	36	40	4	0,1	0,8	150	315	57	–	PCM 323640 M
35	39	20	–	0,1	0,8	54	166	34	PCM 353920 E	–
	39	20	4	0,1	0,8	80	166	31	–	PCM 353920 M
	39	30	–	0,1	0,8	81,5	255	52	PCM 353930 E	–
	39	30	4	0,1	0,8	122	255	47	–	PCM 353930 M
	39	40	–	0,1	0,8	110	345	68	PCM 353940 E	–
	39	50	–	0,1	0,8	137	430	87	PCM 353950 E	–
37	39	50	4	0,1	0,8	208	430	78	–	PCM 353950 M
	40	20	–	0,1	0,8	57	176	27	PCM 374020 E	–
	40	20	4	0,1	0,8	85	176	23	–	PCM 374020 M
40	40	30	4	0,1	0,8	129	270	35	–	PCM 374030 M
	44	20	–	0,1	0,8	61	193	39	PCM 404420 E	–
	44	20	4	0,1	0,8	91,5	193	36	–	PCM 404420 M
	44	30	–	0,1	0,8	93	290	59	PCM 404430 E	–
	44	30	4	0,1	0,8	140	290	53	–	PCM 404430 M
	44	40	–	0,1	0,8	125	390	78	PCM 404440 E	–
44	44	40	4	0,1	0,8	190	390	66	–	PCM 404440 M
	44	50	–	0,1	0,8	156	490	98	PCM 404450 E	–
	44	50	4	0,1	0,8	236	490	89	–	PCM 404450 M

<sup>1)</sup> If no values are given for M, the bushing has no lubrication hole.



Dimensions						Basic load ratings		Mass	Designations	POM composite	
d	D	B	M <sup>1)</sup>	c <sub>1</sub> min	c <sub>2</sub> min	C	C <sub>0</sub>		Straight bushing of PTFE composite		
mm						kN		g	–		
45	50	20	–	0,2	1,2	69,5	216	65	PCM 455020 E	–	
	50	20	5	0,2	1,2	104	216	52	–	PCM 455020 M	
	50	30	–	0,2	1,2	106	325	83	PCM 455030 E	–	
	50	30	5	0,2	1,2	156	325	78	–	PCM 455030 M	
	50	40	–	0,2	1,2	140	440	110	PCM 455040 E	–	
	50	40	5	0,2	1,2	212	440	105	–	PCM 455040 M	
	50	50	–	0,2	1,2	176	550	140	PCM 455050 E	–	
	50	50	5	0,2	1,2	265	550	130	–	PCM 455050 M	
	50	55	20	–	0,2	1,2	76,5	240	62	PCM 505520 E	–
		55	30	–	0,2	1,2	116	365	93	PCM 505530 E	–
55		30	5	0,2	1,2	176	365	86	–	PCM 505530 M	
55		40	–	0,2	1,2	156	490	125	PCM 505540 E	–	
55		40	5	0,2	1,2	236	490	115	–	PCM 505540 M	
55		60	–	0,2	1,2	236	735	185	PCM 505560 E	–	
55		60	5	0,2	1,2	355	735	170	–	PCM 505560 M	
55		60	20	–	0,2	1,2	85	265	67	PCM 556020 E	–
		60	20	6	0,2	1,2	127	265	63	–	PCM 556020 M
		60	25	–	0,2	1,2	106	335	84	PCM 556025 E	–
	60	25	6	0,2	1,2	160	335	78	–	PCM 556025 M	
	60	30	–	0,2	1,2	129	400	100	PCM 556030 E	–	
	60	30	6	0,2	1,2	193	400	94	–	PCM 556030 M	
	60	40	–	0,2	1,2	173	540	135	PCM 556040 E	–	
	60	40	6	0,2	1,2	260	540	125	–	PCM 556040 M	
	60	50	–	0,2	1,2	216	680	170	PCM 556050 E	–	
	60	60	–	0,2	1,2	260	815	200	PCM 556060 B	–	
60	65	20	–	0,2	1,2	91,5	290	75	PCM 606520 E	–	
	65	30	–	0,2	1,2	140	440	110	PCM 606530 E	–	
	65	30	6	0,2	1,2	212	440	100	–	PCM 606530 M	
	65	40	–	0,2	1,2	190	585	145	PCM 606540 E	–	
	65	40	6	0,2	1,2	280	585	135	–	PCM 606540 M	
	65	60	–	0,2	1,2	285	880	220	PCM 606560 E	–	
	65	60	6	0,2	1,2	425	880	205	–	PCM 606560 M	
	65	70	–	0,2	1,2	335	1 040	255	PCM 606570 E	–	
	65	70	6	0,2	1,2	500	1 040	240	–	PCM 606570 M	
	65	70	30	–	0,2	1,2	153	475	120	PCM 657030 E	–
70		50	–	0,2	1,2	255	800	200	PCM 657050 E	–	
70		50	6	0,2	1,2	380	800	185	–	PCM 657050 M	
70		70	–	0,2	1,2	360	1 120	275	PCM 657070 E	–	
70		70	6	0,2	1,2	540	1 120	255	–	PCM 657070 M	

<sup>1)</sup> If no values are given for M, the bushing has no lubrication hole.

# Metric composite straight bushings

d 70 – 135 mm

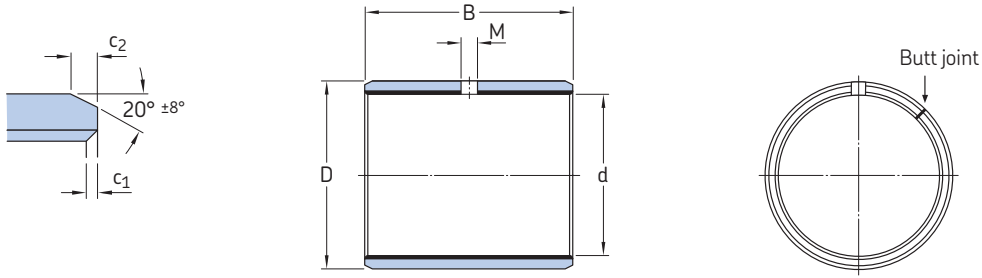

Dimensions						Basic load ratings		Mass	Designations Straight bushing of PTFE composite	POM composite
d	D	B	M <sup>1)</sup>	c <sub>1</sub> min	c <sub>2</sub> min	C	C <sub>0</sub>			
mm						kN		g	–	
70	75	40	–	0,2	1,2	220	680	170	PCM 707540 E	–
	75	50	–	0,2	1,2	275	865	210	PCM 707550 E	–
	75	50	6	0,2	1,2	415	865	195	–	PCM 707550 M
	75	70	–	0,2	1,2	390	1 220	300	PCM 707570 E	–
	75	70	6	0,2	1,2	585	1 220	275	–	PCM 707570 M
75	80	40	6	0,2	1,2	355	735	170	–	PCM 758040 M
	80	50	–	0,2	1,2	300	930	230	PCM 758050 E	–
	80	60	–	0,2	1,2	355	1 100	270	PCM 758060 E	–
	80	60	6	0,2	1,2	530	1 100	255	–	PCM 758060 M
	80	80	–	0,2	1,2	475	1 500	365	PCM 758080 E	–
	80	80	6	0,2	1,2	710	1 500	340	–	PCM 758080 M
80	85	40	6	0,2	1,2	375	780	180	–	PCM 808540 M
	85	60	–	0,2	1,2	375	1 180	290	PCM 808560 E	–
	85	60	6	0,2	1,2	560	1 180	270	–	PCM 808560 M
	85	80	6	0,2	1,2	750	1 560	360	–	PCM 808580 M
	85	100	–	0,2	1,2	630	1 960	485	PCM 8085100 E	–
	85	100	6	0,2	1,2	950	1 960	450	–	PCM 8085100 M
85	90	30	–	0,2	1,2	196	610	150	PCM 859030 E	–
	90	30	6	0,2	1,2	290	610	145	–	PCM 859030 M
	90	60	–	0,2	1,2	400	1 250	305	PCM 859060 E	–
	90	60	6	0,2	1,2	600	1 250	285	–	PCM 859060 M
	90	100	–	0,2	1,2	670	2 080	510	PCM 8590100 E	–
	90	100	6	0,2	1,2	1 000	2 080	475	–	PCM 8590100 M
90	95	60	–	0,2	1,2	425	1 320	325	PCM 909560 E	–
	95	60	6	0,2	1,2	640	1 320	300	–	PCM 909560 M
	95	100	–	0,2	1,2	710	2 240	540	PCM 9095100 E	–
	95	100	6	0,2	1,2	1 060	2 240	505	–	PCM 9095100 M

<sup>1)</sup> If no values are given for M, the bushing has no lubrication hole.

Dimensions						Basic load ratings		Mass	Designations	POM composite	
d	D	B	M <sup>1)</sup>	c <sub>1</sub> min	c <sub>2</sub> min	C	C <sub>0</sub>		Straight bushing of PTFE composite		
mm						kN		g	–		
95	100	30	6	0,2	1,2	325	680	160	–	PCM 9510030 M	
	100	60	–	0,2	1,2	450	1 400	340	PCM 9510060 E	–	
	100	60	6	0,2	1,2	670	1 400	320	–	PCM 9510060 M	
	100	100	–	0,2	1,2	750	2 360	570	PCM 95100100 E	–	
	100	100	6	0,2	1,2	1 120	2 360	530	–	PCM 95100100 M	
100	105	30	6	0,2	1,2	345	720	170	–	PCM 10010530 M	
	105	50	–	0,2	1,2	390	1 220	305	PCM 10010550 E	–	
	105	50	6	0,2	1,2	585	1 220	280	–	PCM 10010550 M	
	105	60	–	0,2	1,2	475	1 460	360	PCM 10010560 E	–	
	105	60	6	0,2	1,2	710	1 460	335	–	PCM 10010560 M	
	105	80	6	0,2	1,2	950	1 960	445	–	PCM 10010580 M	
	105	115	–	0,2	1,2	915	2 850	690	PCM 100105115 E	–	
	105	115	6	0,2	1,2	1 370	2 850	640	–	PCM 100105115 M	
	105	110	60	–	0,2	1,2	490	1 530	375	PCM 10511060 E	–
		110	60	8	0,2	1,2	735	1 530	350	–	PCM 10511060 M
110		115	–	0,2	1,2	950	3 000	725	PCM 105110115 E	–	
110		115	8	0,2	1,2	1 430	3 000	675	–	PCM 105110115 M	
110	115	50	8	0,2	1,2	640	1 340	305	–	PCM 11011550 M	
	115	60	–	0,2	1,2	520	1 630	395	PCM 11011560 E	–	
	115	60	8	0,2	1,2	780	1 630	370	–	PCM 11011560 M	
	115	115	–	0,2	1,2	1 000	3 150	760	PCM 110115115 E	–	
	115	115	8	0,2	1,2	1 500	3 150	705	–	PCM 110115115 M	
115	120	50	–	0,2	1,2	450	1 400	340	PCM 11512050 E	–	
	120	50	8	0,2	1,2	670	1 400	320	–	PCM 11512050 M	
	120	70	–	0,2	1,2	630	1 960	480	PCM 11512070 E	–	
	120	70	8	0,2	1,2	950	1 960	450	–	PCM 11512070 M	
120	125	60	–	0,2	1,2	560	1 760	430	PCM 12012560 E	–	
	125	60	8	0,2	1,2	850	1 760	400	–	PCM 12012560 M	
	125	100	–	0,2	1,2	950	3 000	715	PCM 120125100 E	–	
	125	100	8	0,2	1,2	1 430	3 000	665	–	PCM 120125100 M	
	125	120	–	0,2	1,2	1 140	3 550	880	PCM 120125120 E	–	
125	130	100	–	0,2	1,2	980	3 100	745	PCM 125130100 E	–	
	130	100	8	0,2	1,2	1 500	3 100	695	–	PCM 125130100 M	
130	135	60	–	0,2	1,2	610	1 900	465	PCM 13013560 E	–	
	135	60	8	0,2	1,2	915	1 900	435	–	PCM 13013560 M	
	135	100	–	0,2	1,2	1 020	3 200	775	PCM 130135100 E	–	
	135	100	8	0,2	1,2	1 530	3 200	720	–	PCM 130135100 M	
135	140	60	–	0,2	1,2	640	2 000	480	PCM 13514060 E	–	
	140	60	8	0,2	1,2	950	2 000	450	–	PCM 13514060 M	
	140	80	–	0,2	1,2	850	2 650	645	PCM 13514080 E	–	
	140	80	8	0,2	1,2	1 270	2 650	600	–	PCM 13514080 M	

<sup>1)</sup> If no values are given for M, the bushing has no lubrication hole.

# Metric composite straight bushings

d 140 – 300 mm

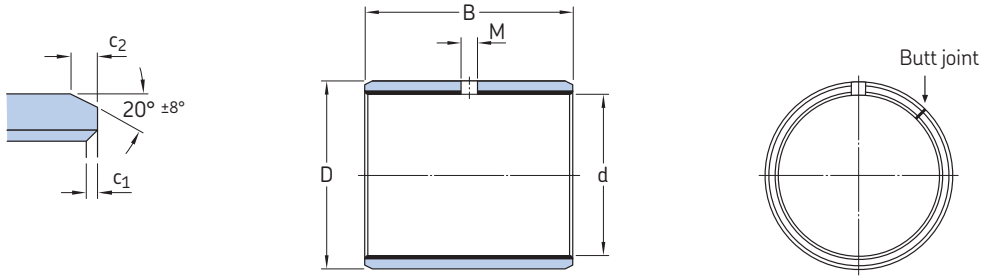

Dimensions						Basic load ratings		Mass	Designations Straight bushing of PTFE composite	POM composite
d	D	B	M <sup>1)</sup>	c <sub>1</sub> min	c <sub>2</sub> min	C	C <sub>0</sub>			
mm						kN		kg	–	
<b>140</b>	145	60	–	0,2	1,2	655	2 040	0,50	PCM 14014560 E	–
	145	60	8	0,2	1,2	980	2 040	0,47	–	PCM 14014560 M
	145	100	–	0,2	1,2	1 100	3 450	0,84	PCM 140145100 E	–
	145	100	8	0,2	1,2	1 660	3 450	0,78	–	PCM 140145100 M
	145	120	–	0,2	1,2	1 340	4 150	1,00	PCM 140145120 E	–
<b>150</b>	155	60	–	0,2	1,2	710	2 200	0,54	PCM 15015560 E	–
	155	60	8	0,2	1,2	1 060	2 200	0,50	–	PCM 15015560 M
	155	80	–	0,2	1,2	950	3 000	0,72	PCM 15015580 E	–
	155	80	8	0,2	1,2	1 430	3 000	0,67	–	PCM 15015580 M
	155	100	–	0,2	1,2	1 200	3 750	0,89	PCM 150155100 E	–
	155	100	8	0,2	1,2	1 800	3 750	0,83	–	PCM 150155100 M
<b>160</b>	165	80	–	0,2	1,2	1 000	3 150	0,78	PCM 16016580 E	–
	165	80	8	0,2	1,2	1 500	3 150	0,71	–	PCM 16016580 M
	165	100	–	0,2	1,2	1 270	3 900	0,97	PCM 160165100 E	–
	165	100	8	0,2	1,2	1 900	3 900	0,89	–	PCM 160165100 M
<b>180</b>	185	80	–	0,2	1,2	1 140	3 550	0,87	PCM 18018580 E	–
	185	80	8	0,2	1,2	1 700	3 550	0,80	–	PCM 18018580 M
	185	100	–	0,2	1,2	1 430	4 400	1,10	PCM 180185100 E	–
	185	100	8	0,2	1,2	2 120	4 400	1,00	–	PCM 180185100 M
<b>190</b>	195	60	8	0,2	1,2	1 340	2 800	0,63	–	PCM 19019560 M
	195	100	8	0,2	1,2	2 240	4 650	1,05	–	PCM 190195100 M
<b>200</b>	205	100	–	0,2	1,2	1 600	4 900	1,20	PCM 200205100 E	–
	205	100	8	0,2	1,2	2 360	4 900	1,10	–	PCM 200205100 M
<b>210</b>	215	100	–	0,2	1,2	1 660	5 200	1,25	PCM 210215100 E	–
	215	100	8	0,2	1,2	2 500	5 200	1,15	–	PCM 210215100 M
<b>220</b>	225	100	–	0,2	1,2	1 730	5 400	1,35	PCM 220225100 E	–
	225	100	8	0,2	1,2	2 600	5 400	1 20	–	PCM 220225100 M

<sup>1)</sup> If no values are given for M, the bushing has no lubrication hole.

Dimensions						Basic load ratings		Mass	Designations Straight bushing of PTFE composite	POM composite
d	D	B	M <sup>1)</sup>	c <sub>1</sub> min	c <sub>2</sub> min	C	C <sub>0</sub>			
mm						kN		kg	–	
250	255	100	–	0,2	1,2	1 960	6 100	1,50	PCM 250255100 E	–
	255	100	8	0,2	1,2	3 000	6 100	1,40	–	PCM 250255100 M
280	285	80	–	0,2	1,2	1 760	5 500	1,35	PCM 28028580 E	–
	285	80	8	0,2	1,2	2 650	5 500	1,25	–	PCM 28028580 M
300	305	50	–	0,2	1,2	1 180	3 650	0,90	PCM 30030550 E	–
	305	50	8	0,2	1,2	1 760	3 650	0,83	–	PCM 30030550 M
	305	100	–	0,2	1,2	2 360	7 350	1,80	PCM 300305100 E	–
	305	100	8	0,2	1,2	3 550	7 350	1,65	–	PCM 300305100 M

<sup>1)</sup> If no values are given for M, the bushing has no lubrication hole.

# Inch composite straight bushings

d 1/8 – 1 3/4 in

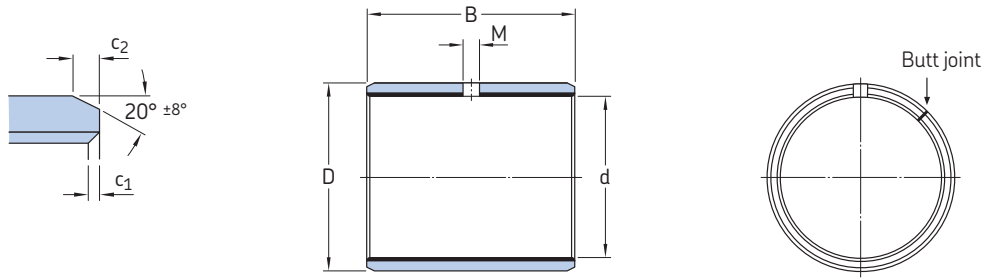

Dimensions						Basic load ratings		Mass	Designations				
						dynamic	static		Straight bushing of				
d	D		B	M <sup>1)</sup>	c <sub>1</sub> min	c <sub>2</sub> min	C	C <sub>0</sub>	g	PTFE composite	POM composite		
in	mm	in	mm	in	mm		kN			–	–		
1/8	3,175	3/16	4,763	1/8	3,175	–	0,1	0,2	0,8	2,5	0,23	PCZ 0202 E	–
		3/16	4,763	3/16	4,763	–	0,1	0,2	1,2	3,75	0,34	PCZ 0203 E	–
3/16	4,763	1/4	6,350	3/16	4,763	–	0,1	0,2	1,8	5,7	0,48	PCZ 0303 E	–
		1/4	6,350	1/4	6,35	–	0,1	0,2	2,4	7,5	0,63	PCZ 0304 E	–
		1/4	6,350	3/8	9,525	–	0,1	0,2	3,65	11,4	0,95	PCZ 0306 E	–
1/4	6,35	5/16	7,938	1/4	6,35	–	0,1	0,2	3,25	10	0,81	PCZ 0404 E	–
		5/16	7,938	3/8	9,525	–	0,1	0,2	4,8	15	1,2	PCZ 0406 E	–
5/16	7,938	3/8	9,525	3/8	9,525	–	0,1	0,2	6	19	1,5	PCZ 0506 E	–
		3/8	9,525	1/2	12,7	–	0,1	0,2	8	25	2,0	PCZ 0508 E	–
3/8	9,525	15/32	11,906	3/8	9,525	–	0,1	0,2	7,2	22,8	2,8	PCZ 0606 E	–
		15/32	11,906	3/8	9,525	–	0,1	0,2	10,8	22,8	2,3	–	PCZ 0606 M
		15/32	11,906	1/2	12,7	–	0,1	0,2	9,8	30	3,8	PCZ 0608 E	–
		15/32	11,906	1/2	12,7	–	0,1	0,2	11,4	30	3,0	–	PCZ 0608 M
		15/32	11,906	3/4	19,05	–	0,1	0,2	14,6	45,5	5,8	PCZ 0612 E	–
		15/32	11,906	3/4	19,05	–	0,1	0,2	21,6	45,5	4,6	–	PCZ 0612 M
7/16	11,113	17/32	13,494	1/2	12,7	–	0,1	0,2	11,2	35,5	4,3	PCZ 0708 E	–
		17/32	13,494	1/2	12,7	3	0,1	0,2	17	35,5	3,5	–	PCZ 0708 M
		17/32	13,494	3/4	19,05	–	0,1	0,2	17	53	6,5	PCZ 0712 E	–
		17/32	13,494	3/4	19,05	3	0,1	0,2	25,5	53	5,2	–	PCZ 0712 M
1/2	12,7	19/32	15,081	3/8	9,525	–	0,1	0,2	9,8	30	3,7	PCZ 0806 E	–
		19/32	15,081	3/8	9,525	3	0,1	0,2	14,6	30	3,0	–	PCZ 0806 M
		19/32	15,081	1/2	12,7	–	0,1	0,2	12,9	41/2	4,9	PCZ 0808 E	–
		19/32	15,081	1/2	12,7	3	0,1	0,2	19,3	41/2	3,9	–	PCZ 0808 M
		19/32	15,081	5/8	15,875	–	0,1	0,2	16	50	6,1	PCZ 0810 E	–
		19/32	15,081	5/8	15,875	3	0,1	0,2	24	50	4,9	–	PCZ 0810 M
		19/32	15,081	7/8	22,225	–	0,1	0,2	22,4	71	8,5	PCZ 0814 E	–
		19/32	15,081	7/8	22,225	3	0,1	0,2	33,4	71	6,9	–	PCZ 0814 M
9/16	14,288	21/32	16,669	1/2	12,7	–	0,1	0,2	14,6	45,5	5,4	PCZ 0908 E	–
		21/32	16,669	1/2	12,7	3	0,1	0,2	21,6	45,5	4,4	–	PCZ 0908 M
		21/32	16,669	3/4	19,05	–	0,1	0,2	21,6	68	8,2	PCZ 0912 E	–
		21/32	16,669	3/4	19,05	3	0,1	0,2	32,5	68	6,6	–	PCZ 0912 M
5/8	15,875	23/32	18,256	1/2	12,7	–	0,1	0,2	16	50	6,0	PCZ 1008 E	–
		23/32	18,256	1/2	12,7	3	0,1	0,2	24	50	4,9	–	PCZ 1008 M
		23/32	18,256	5/8	15,875	–	0,1	0,2	20	63	7,5	PCZ 1010 E	–
		23/32	18,256	5/8	15,875	3	0,1	0,2	30	63	6,1	–	PCZ 1010 M
		23/32	18,256	3/4	19,05	–	0,1	0,2	24	75	9,0	PCZ 1012 E	–
		23/32	18,256	3/4	19,05	3	0,1	0,2	36	75	7,3	–	PCZ 1012 M
		23/32	18,256	7/8	22,225	–	0,1	0,2	28	88	10,5	PCZ 1014 E	–
		23/32	18,256	7/8	22,225	3	0,1	0,2	42,5	88	8,5	–	PCZ 1014 M

<sup>1)</sup> If no values are given for M, the bushing has no lubrication hole.

Dimensions						Basic load ratings			Mass	Designations			
dynamic		static		Straight bushing of PTFE composite	POM composite								
d	D	B	M <sup>1)</sup>			c <sub>1</sub> min	c <sub>2</sub> min	C	C <sub>0</sub>				
in	mm	in	mm	in	mm	kN	g	-					
1 <sup>1</sup> / <sub>16</sub>	17,463	2 <sup>5</sup> / <sub>32</sub>	19,844	7/8	22,225	-	0,1	0,2	31	96,5	11	PCZ 1114 E	-
		2 <sup>5</sup> / <sub>32</sub>	19,844	7/8	22,225	3	0,1	0,2	46,5	96,5	9,3	-	PCZ 1114 M
3/4	19,05	7/8	22,225	1/2	12,7	-	0,1	0,2	18,3	56	9,8	PCZ 1208 E	-
		7/8	22,225	1/2	12,7	3	0,1	0,2	27	56	8,4	-	PCZ 1208 M
		7/8	22,225	3/4	19,05	-	0,1	0,2	28	86,5	15	PCZ 1212 E	-
		7/8	22,225	3/4	19,05	3	0,1	0,2	41,5	86,5	13	-	PCZ 1212 M
		7/8	22,225	1	25,4	-	0,1	0,2	37,5	118	20	PCZ 1216 E	-
7/8	22,225	7/8	22,225	1	25,4	3	0,1	0,2	56	118	17	-	PCZ 1216 M
		1	25,4	3/4	19,05	-	0,1	0,2	32,5	102	17	PCZ 1412 E	-
		1	25,4	3/4	19,05	4	0,1	0,2	49	102	15	-	PCZ 1412 M
		1	25,4	7/8	22,225	-	0,1	0,2	38	120	20	PCZ 1414 E	-
		1	25,4	7/8	22,225	4	0,1	0,2	57	120	17	-	PCZ 1414 M
1	25,4	1	25,4	1	25,4	-	0,1	0,2	44	137	23	PCZ 1416 E	-
		1	25,4	1	25,4	4	0,1	0,2	65,5	137	19	-	PCZ 1416 M
		1 1/8	28,575	3/4	19,05	-	0,1	0,2	37,5	116	19	PCZ 1612 E	-
		1 1/8	28,575	3/4	19,05	4	0,1	0,2	56	116	17	-	PCZ 1612 M
		1 1/8	28,575	1	25,4	-	0,1	0,2	50	156	26	PCZ 1616 E	-
1 1/8	28,575	1 1/8	28,575	1	25,4	4	0,1	0,2	75	156	22	-	PCZ 1616 M
		1 1/8	28,575	1 1/2	38,1	-	0,1	0,2	76,5	236	38	PCZ 1624 E	-
		1 1/8	28,575	1 1/2	38,1	4	0,1	0,2	115	236	33	-	PCZ 1624 M
		1 9/32	32,544	3/4	19,05	-	0,1	0,8	41,5	129	27	PCZ 1812 E	-
		1 9/32	32,544	3/4	19,05	4	0,1	0,8	63	129	24	-	PCZ 1812 M
1 1/4	31,75	1 9/32	32,544	1	25,4	-	0,1	0,8	56	176	36	PCZ 1816 E	-
		1 9/32	32,544	1	25,4	4	0,1	0,8	85	176	32	-	PCZ 1816 M
		1 13/32	35,719	3/4	19,05	-	0,1	0,8	46,5	146	30	PCZ 2012 E	-
		1 13/32	35,719	3/4	19,05	4	0,1	0,8	69,5	146	27	-	PCZ 2012 M
1 3/8	34,925	1 13/32	35,719	1	25,4	-	0,1	0,8	64	196	40	PCZ 2016 E	-
		1 13/32	35,719	1	25,4	4	0,1	0,8	93	196	36	-	PCZ 2016 M
		1 13/32	35,719	1 1/4	31,75	-	0,1	0,8	78	245	50	PCZ 2020 E	-
		1 13/32	35,719	1 1/4	31,75	4	0,1	0,8	118	245	45	-	PCZ 2020 M
		1 13/32	35,719	1 3/4	44,45	-	0,1	0,8	110	345	71	PCZ 2028 E	-
		1 13/32	35,719	1 3/4	44,45	4	0,1	0,8	166	345	63	-	PCZ 2028 M
		1 17/32	38,894	1	25,4	-	0,1	0,8	68	216	44	PCZ 2216 E	-
		1 17/32	38,894	1	25,4	4	0,1	0,8	104	216	39	-	PCZ 2216 M
1 1/2	38,1	1 17/32	38,894	1 3/8	34,925	-	0,1	0,8	95	300	61	PCZ 2222 E	-
		1 17/32	38,894	1 3/8	34,925	4	0,1	0,8	143	300	54	-	PCZ 2222 M
		1 17/32	38,894	1 3/4	44,45	-	0,1	0,8	122	380	77	PCZ 2228 E	-
		1 17/32	38,894	1 3/4	44,45	4	0,1	0,8	183	380	69	-	PCZ 2228 M
		1 21/32	42,069	1	25,4	-	0,1	0,8	75	236	48	PCZ 2416 E	-
1 5/8	41,275	1 21/32	42,069	1	25,4	4	0,1	0,8	112	236	43	-	PCZ 2416 M
		1 21/32	42,069	1 1/4	31,75	-	0,1	0,8	95	290	60	PCZ 2420 E	-
		1 21/32	42,069	1 1/4	31,75	4	0,1	0,8	143	290	53	-	PCZ 2420 M
		1 21/32	42,069	1 1/2	38,1	-	0,1	0,8	114	355	72	PCZ 2424 E	-
		1 21/32	42,069	1 1/2	38,1	4	0,1	0,8	170	355	64	-	PCZ 2424 M
		1 21/32	42,069	2	50,8	-	0,1	0,8	153	475	96	PCZ 2432 E	-
		1 21/32	42,069	2	50,8	4	0,1	0,8	228	475	85	-	PCZ 2432 M
		1 25/32	45,244	1	25,4	-	0,1	0,8	81,5	255	53	PCZ 2616 E	-
1 3/4	44,45	1 25/32	45,244	1	25,4	5	0,1	0,8	122	255	46	-	PCZ 2616 M
		1 25/32	45,244	1 1/2	38,1	-	0,1	0,8	122	380	78	PCZ 2624 E	-
		1 25/32	45,244	1 1/2	38,1	5	0,1	0,8	186	380	69	-	PCZ 2624 M
		1 15/16	49,213	1	25,4	-	0,2	1,2	88	275	68	PCZ 2816 E	-
1 15/16	49,213	1 15/16	49,213	1	25,4	5	0,2	1,2	132	275	61	-	PCZ 2816 M
		1 15/16	49,213	1 1/2	38,1	-	0,2	1,2	132	415	100	PCZ 2824 E	-
		1 15/16	49,213	1 1/2	38,1	5	0,2	1,2	200	415	92	-	PCZ 2824 M
		1 15/16	49,213	1 3/4	44,45	-	0,2	1,2	156	490	120	PCZ 2828 E	-
		1 15/16	49,213	1 3/4	44,45	5	0,2	1,2	232	490	110	-	PCZ 2828 M
		1 15/16	49,213	2	50,8	-	0,2	1,2	180	560	140	PCZ 2832 E	-
		1 15/16	49,213	2	50,8	5	0,2	1,2	265	560	130	-	PCZ 2832 M

<sup>1)</sup> If no values are given for M, the bushing has no lubrication hole.

# Inch composite straight bushings

d 1 7/8 – 7 in

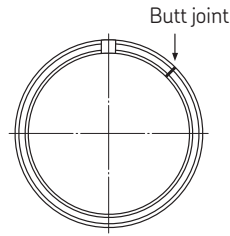
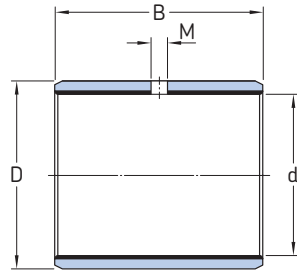
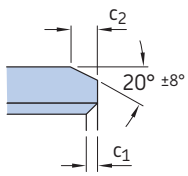

Dimensions						Basic load ratings		Mass	Designations				
d	D	B	M <sup>1)</sup>	c <sub>1</sub> min	c <sub>2</sub> min	dynamic	static		Straight bushing of PTFE composite	POM composite			
in	mm	in	mm			kN	C <sub>0</sub>	g	–	–			
1 7/8	47,625	2 1/16	52,388	1	25,4	–	0,2	1,2	93	290	72	PCZ 3016 E	–
		2 1/16	52,388	1	25,4	5	0,2	1,2	140	290	66	–	PCZ 3016 M
		2 1/16	52,388	1 7/8	47,625	–	0,2	1,2	180	560	135	PCZ 3030 E	–
		2 1/16	52,388	1 7/8	47,625	5	0,2	1,2	270	560	125	–	PCZ 3030 M
		2 1/16	52,388	2 1/4	57,15	–	0,2	1,2	216	670	160	PCZ 3036 E	–
		2 1/16	52,388	2 1/4	57,15	5	0,2	1,2	320	670	145	–	PCZ 3036 M
2	50,8	2 3/16	55,563	1	25,4	–	0,2	1,2	100	310	77	PCZ 3216 E	–
		2 3/16	55,563	1	25,4	6	0,2	1,2	150	310	70	–	PCZ 3216 M
		2 3/16	55,563	1 1/2	38,1	–	0,2	1,2	153	475	115	PCZ 3224 E	–
		2 3/16	55,563	1 1/2	38,1	6	0,2	1,2	228	475	105	–	PCZ 3224 M
		2 3/16	55,563	2	50,8	–	0,2	1,2	204	640	155	PCZ 3232 E	–
		2 3/16	55,563	2	50,8	6	0,2	1,2	305	640	140	–	PCZ 3232 M
		2 3/16	55,563	2 1/2	63,5	–	0,2	1,2	255	800	190	PCZ 3240 E	–
		2 3/16	55,563	2 1/2	63,5	6	0,2	1,2	380	800	175	–	PCZ 3240 M
2 1/4	57,15	2 7/16	61,913	2	50,8	–	0,2	1,2	228	710	170	PCZ 3632 E	–
		2 7/16	61,913	2	50,8	6	0,2	1,2	345	710	155	–	PCZ 3632 M
		2 7/16	61,913	2 1/4	57,15	–	0,2	1,2	260	800	195	PCZ 3636 E	–
		2 7/16	61,913	2 1/4	57,15	6	0,2	1,2	390	800	175	–	PCZ 3636 M
		2 7/16	61,913	2 1/2	63,5	–	0,2	1,2	285	900	215	PCZ 3640 E	–
		2 7/16	61,913	2 1/2	63,5	6	0,2	1,2	430	900	195	–	PCZ 3640 M
		2 7/16	61,913	3	76,2	–	0,2	1,2	345	1 080	250	PCZ 3648 E	–
2 1/2	63,5	2 11/16	68,263	2	50,8	–	0,2	1,2	255	800	190	PCZ 4032 E	–
		2 11/16	68,263	2	50,8	6	0,2	1,2	380	800	175	–	PCZ 4032 M
		2 11/16	68,263	2 1/2	63,5	–	0,2	1,2	320	1 000	240	PCZ 4040 E	–
		2 11/16	68,263	2 1/2	63,5	6	0,2	1,2	480	1 000	215	–	PCZ 4040 M
		2 11/16	68,263	3	76,2	–	0,2	1,2	380	1 200	285	PCZ 4048 E	–
		2 11/16	68,263	3 1/2	88,9	–	0,2	1,2	450	1 400	335	PCZ 4056 E	–
2 3/4	69,85	2 15/16	74,613	2	50,8	–	0,2	1,2	280	880	210	PCZ 4432 E	–
		2 15/16	74,613	2	50,8	6	0,2	1,2	415	880	190	–	PCZ 4432 M
		2 15/16	74,613	2 1/2	63,5	–	0,2	1,2	355	1 100	260	PCZ 4440 E	–
		2 15/16	74,613	2 1/2	63,5	6	0,2	1,2	530	1 100	235	–	PCZ 4440 M
		2 15/16	74,613	3	76,2	–	0,2	1,2	425	1 320	315	PCZ 4448 E	–
		2 15/16	74,613	3	76,2	6	0,2	1,2	630	1 320	285	–	PCZ 4448 M
		2 15/16	74,613	3 1/2	88,9	–	0,2	1,2	490	1 530	365	PCZ 4456 E	–
		2 15/16	74,613	3 1/2	88,9	6	0,2	1,2	735	1 530	330	–	PCZ 4456 M
		–	–	–	–	–	–	–	–	–	–	–	–
3	76,2	3 3/16	80,963	2	50,8	–	0,2	1,2	305	950	225	PCZ 4832 E	–
		3 3/16	80,963	2	50,8	6	0,2	1,2	455	950	205	–	PCZ 4832 M
		3 3/16	80,963	3	76,2	–	0,2	1,2	455	1 430	340	PCZ 4848 E	–
		3 3/16	80,963	3	76,2	6	0,2	1,2	695	1 430	310	–	PCZ 4848 M
		3 3/16	80,963	3 3/4	95,25	–	0,2	1,2	570	1 800	425	PCZ 4860 E	–
		3 3/16	80,963	3 3/4	95,25	6	0,2	1,2	865	1 800	385	–	PCZ 4860 M

<sup>1)</sup> If no values are given for M, the bushing has no lubrication hole.



Dimensions									Basic load ratings		Mass	Designations	
d		D		B		M <sup>1)</sup>	c <sub>1</sub> min	c <sub>2</sub> min	C	C <sub>0</sub>		g	Straight bushing of PTFE composite POM composite
in	mm	in	mm	in	mm				kN				-
3 1/2	88,9	3 11/16	93,663	2 1/2	63,5	-	0,2	1,2	440	1 370	330	PCZ 5640 E	-
		3 11/16	93,663	2 1/2	63,5	6	0,2	1,2	670	1 370	300	-	PCZ 5640 M
		3 11/16	93,663	3	76,2	-	0,2	1,2	530	1 660	395	PCZ 5648 E	-
		3 11/16	93,663	3	76,2	6	0,2	1,2	800	1 660	360	-	PCZ 5648 M
		3 11/16	93,663	3 3/4	95,25	-	0,2	1,2	670	2 080	495	PCZ 5660 E	-
		3 11/16	93,663	3 3/4	95,25	6	0,2	1,2	1000	2 080	450	-	PCZ 5660 M
4	101,6	4 3/16	106,363	3	76,2	-	0,2	1,2	610	1 900	450	PCZ 6448 E	-
		4 3/16	106,363	3	76,2	8	0,2	1,2	915	1 900	410	-	PCZ 6448 M
		4 3/16	106,363	3 3/4	95,25	-	0,2	1,2	765	2 400	565	PCZ 6460 E	-
		4 3/16	106,363	3 3/4	95,25	8	0,2	1,2	1 140	2 400	510	-	PCZ 6460 M
		4 3/16	106,363	4 3/4	120,65	-	0,2	1,2	965	3 050	715	PCZ 6476 E	-
		4 3/16	106,363	4 3/4	120,65	8	0,2	1,2	1 460	3 050	645	-	PCZ 6476 M
5	127	5 3/16	131,763	3	76,2	-	0,2	1,2	765	2 400	560	PCZ 8048 E	-
		5 3/16	131,763	3 3/4	95,25	-	0,2	1,2	950	3 000	700	PCZ 8060 E	-
6	152,4	6 3/16	157,163	3	76,2	-	0,2	1,2	915	2 850	670	PCZ 9648 E	-
		6 3/16	157,163	3 3/4	95,25	-	0,2	1,2	1 146	3 600	840	PCZ 9660 E	-
7	177,8	7 3/16	182,563	3 3/4	95,25	-	0,2	1,2	1 340	4 150	975	PCZ 11260 E	-

<sup>1)</sup> If no values are given for M, the bushing has no lubrication hole.

# Composite flanged bushings

d 6 – 35 mm

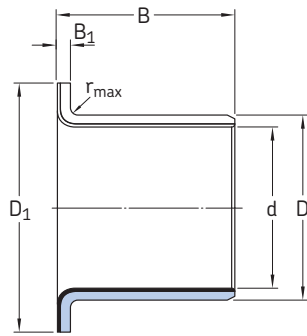
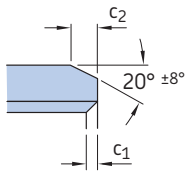

Butt joint

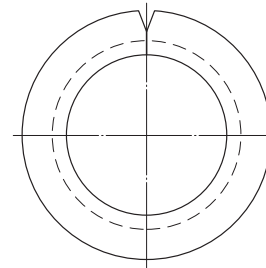

Dimensions								Basic load ratings				Mass	Designations
d	D	B	D <sub>1</sub>	B <sub>1</sub>	c <sub>1</sub> min	c <sub>2</sub> min	r <sub>max</sub>	radial dynamic C	static C <sub>0</sub>	axial dynamic C <sub>a</sub>	static C <sub>0a</sub>	g	Bushings of PTFE composite Material E
mm								kN				g	-
6	8	4	12	1	0,1	0,2	1	0,965	3	2,75	8,65	1,3	PCMF 060804 E
	8	8	12	1	0,1	0,2	1	2,9	9	2,75	8,65	1,9	PCMF 060808 E
8	10	5,5	15	1	0,1	0,2	1	2,24	6,95	5,1	16	2,1	PCMF 081005.5 E
	10	7,5	15	1	0,1	0,2	1	3,55	11	5,1	16	2,5	PCMF 081007.5 E
	10	9,5	15	1	0,1	0,2	1	4,8	15	5,1	16	2,9	PCMF 081009.5 E
10	12	7	18	1	0,1	0,2	1	4	12,5	8	25	3,1	PCMF 101207 E
	12	9	18	1	0,1	0,2	1	5,6	17,6	8	25	3,6	PCMF 101209 E
	12	12	18	1	0,1	0,2	1	8	25	8	25	4,3	PCMF 101212 E
	12	17	18	1	0,1	0,2	1	12	37,5	8	25	5,6	PCMF 101217 E
12	14	7	20	1	0,1	0,2	1	4,8	15	9,15	28,5	3,6	PCMF 121407 E
	14	9	20	1	0,1	0,2	1	6,7	20,8	9,15	28,5	4,2	PCMF 121409 E
	14	12	20	1	0,1	0,2	1	9,65	30	9,15	28,5	5,1	PCMF 121412 E
	14	15	20	1	0,1	0,2	1	12,5	39	9,15	28,5	6,1	PCMF 121415 E
	14	17	20	1	0,1	0,2	1	14,3	45	9,15	28,5	6,6	PCMF 121417 E
14	16	12	22	1	0,1	0,2	1	11	34,5	10	31,5	5,8	PCMF 141612 E
	16	17	22	1	0,1	0,2	1	16,6	52	10	31,5	7,5	PCMF 141617 E
15	17	9	23	1	0,1	0,2	1	8,3	26	10,4	32,5	5,1	PCMF 151709 E
	17	12	23	1	0,1	0,2	1	12	37,5	10,4	32,5	6,2	PCMF 151712 E
	17	17	23	1	0,1	0,2	1	18	56	10,4	32,5	7,6	PCMF 151717 E
16	18	12	24	1	0,1	0,2	1	12,2	38	8,5	26,5	6,2	PCMF 161812 E
	18	17	24	1	0,1	0,2	1	18,6	58,5	8,5	26,5	8,1	PCMF 161817 E
18	20	12	26	1	0,1	0,2	1	13,7	42,5	9,3	29	7,3	PCMF 182012 E
	20	17	26	1	0,1	0,2	1	20,8	65,5	9,3	29	9,5	PCMF 182017 E
	20	22	26	1	0,1	0,2	1	28	88	9,3	29	12	PCMF 182022 E
20	23	11,5	30	1,5	0,1	0,2	1,5	14,3	45	17,3	54	13	PCMF 202311.5 E
	23	15	30	1,5	0,1	0,2	1,5	20	62	17,3	54	16	PCMF 202315 E
	23	16,5	30	1,5	0,1	0,2	1,5	22	69,5	17,3	54	17	PCMF 202316.5 E
	23	21,5	30	1,5	0,1	0,2	1,5	31/2	95	17,3	54	21	PCMF 202321.5 E
25	28	11,5	35	1,5	0,1	0,2	1,5	17,3	54	20,4	64	16	PCMF 252811.5 E
	28	16,5	35	1,5	0,1	0,2	1,5	28	85	20,4	64	21	PCMF 252816.5 E
	28	21,5	35	1,5	0,1	0,2	1,5	37,5	116	20,4	64	25	PCMF 252821.5 E
30	34	16	42	2	0,1	0,8	2	30,5	95	29	91,5	35	PCMF 303416 E
	34	26	42	2	0,1	0,8	2	54	170	29	91,5	50	PCMF 303426 E
35	39	16	47	2	0,1	0,8	2	35,5	110	33,5	104	43	PCMF 353916 E
	39	26	47	2	0,1	0,8	2	63	196	33,5	104	61	PCMF 353926 E

## Composite thrust washers

d 12 – 62 mm

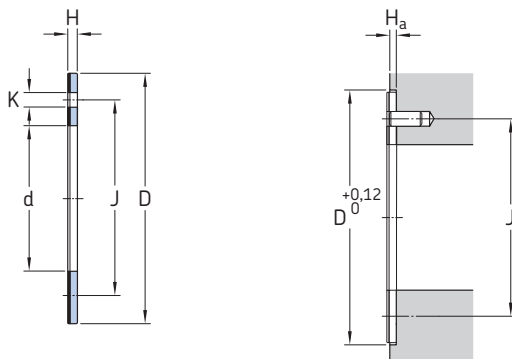

Dimensions						Basic load ratings		Mass	Designations	
d	D	H	J	K	H <sub>a</sub>	dynamic	static		Washer of PTFE composite	POM composite
±0,25	0/-0,25		±0,12	±0,15		C	C <sub>0</sub>			
mm						kN		g	-	
12	24	1,5	18	1,75	1	28	85	3,8	PCMW 122401.5 E	-
	24	1,5	18	1,75	1	40,5	85	3,2	-	PCMW 122401.5 M
14	26	1,5	20	2,25	1	30	93	4,2	PCMW 142601.5 E	-
	26	1,5	20	2,25	1	45	93	3,6	-	PCMW 142601.5 M
18	32	1,5	25	2,25	1	44	137	6,1	PCMW 183201.5 E	-
	32	1,5	25	2,25	1	65,5	137	5,3	-	PCMW 183201.5 M
20	36	1,5	28	3,25	1	56	176	7,8	PCMW 203601.5 E	-
	36	1,5	28	3,25	1	85	176	6,7	-	PCMW 203601.5 M
22	38	1,5	30	3,25	1	60	186	8,8	PCMW 223801.5 E	-
	38	1,5	30	3,25	1	90	186	7,7	-	PCMW 223801.5 M
26	44	1,5	35	3,25	1	78	245	11	PCMW 264401.5 E	-
	44	1,5	35	3,25	1	118	245	9,4	-	PCMW 264401.5 M
28	48	1,5	38	4,25	1	93	290	13	PCMW 284801.5 E	-
	48	1,5	38	4,25	1	140	290	11	-	PCMW 284801.5 M
32	54	1,5	43	4,25	1	116	365	16	PCMW 325401.5 E	-
	54	1,5	43	4,25	1	176	365	14	-	PCMW 325401.5 M
38	62	1,5	50	4,25	1	150	465	21	PCMW 386201.5 E	-
	62	1,5	50	4,25	1	224	465	18	-	PCMW 386201.5 M
42	66	1,5	54	4,25	1	163	510	23	PCMW 426601.5 E	-
	66	1,5	54	4,25	1	240	510	19	-	PCMW 426601.5 M
48	74	2	61	4,25	1,5	200	620	37	PCMW 487402 E	-
	74	2	61	4,25	1,5	300	620	34	-	PCMW 487402 M
52	78	2	65	4,25	1,5	208	655	39	PCMW 527802 E	-
	78	2	65	4,25	1,5	315	655	36	-	PCMW 527802 M
62	90	2	76	4,25	1,5	265	830	52	PCMW 629002 E	-

**Composite strips**  
H 1 – 3,06 mm

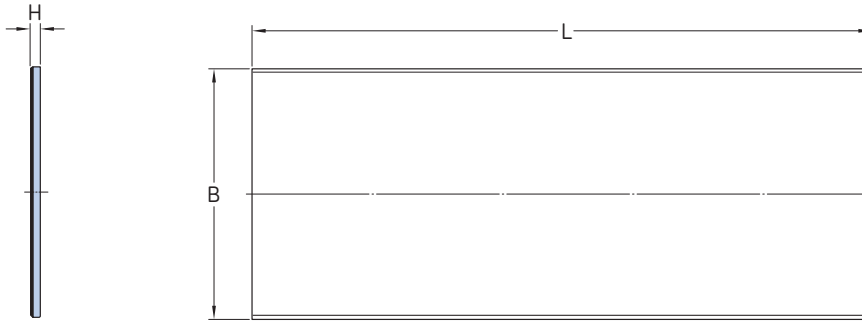

Due to manufacturing the usable width of Composite strips may be smaller than the nominal width.

Dimensions			Mass	Designations	
H	B ±0,5	L +3		Strip of PTFE composite	POM composite
mm			kg	–	
1	200	500	0,83	PCMS 2005001.0 E	–
	200	500	0,28	–	PCMS 2005001.0 M
1,5	200	500	1,25	PCMS 2005001.5 E	–
	200	500	0,93	–	PCMS 2005001.5 M
2	200	500	1,66	PCMS 2005002.0 E	–
	200	500	1,34	–	PCMS 2005002.0 M
2,5	200	500	2,08	PCMS 2005002.5 E	–
	200	500	1,76	–	PCMS 2005002.5 M
3,06	200	500	2,24	PCMS 2005003.06 E	–
	200	500	2,15	–	PCMS 2005003.06 M



# Related SKF products

## Maintenance-free filament wound bushings

Filament wound bushings are produced by winding a self-lubricating composite. The sliding layer consists of strands of high-strength polyester and reinforced PTFE (polytetrafluoroethylene) in an epoxy resin matrix. The shell or backing is made of wound high-strength tensioned glass fibre also in an epoxy resin matrix. The sliding and backing layers are firmly anchored to each other. Both layers are produced by winding endless strands in a crisscross pattern.

Modern filament winding technology has made it possible to combine the special mechanical properties of glass fibre with the excellent tribological properties of high-strength thermoplastic and PTFE fibres

embedded in epoxy resin to produce a new innovative bearing material. The defined position of the strands in the crisscross pattern and the intensive binding between the strands and the resin provide very high load carrying capacity and wear-resistance.

Maintenance-free plain bearings, series designation PWM, are only available as cylindrical bushings. They are intended for oscillating, rotational and linear movement, where there is risk of heavy edge loading and/or where chemical resistance and maintenance-free operation are required. They can be used at temperatures between  $-50$  and  $+140$  °C.

## Assortment

The range of SKF maintenance-free PWM bushings currently comprises bushings with bore diameters ranging from 20 to 300 mm.

## Further information

More information about PWM bushings can be found in the

- “SKF Interactive Engineering Catalogue” online at [www.skf.com](http://www.skf.com)
- brochure “SKF bushings”
- brochure “Filament wound bushings, PWM series”.



## SKF spherical plain bearings

For arrangements where alignment movements have to be accommodated between two components in relative motion or where tilting movements or oscillations occur at relatively low sliding velocities, spherical plain bearings are an excellent solution. They have an inner ring with a sphered convex outside surface and an outer ring with a correspondingly sphered but concave inside surface. Wherever spherical plain bearings are needed, whether maintenance-free or not, SKF spherical plain bearings can do the job.

Spherical plain bearings with steel-on-steel sliding contact surfaces require maintenance. The high wear-resistance of the sliding surfaces makes these bearings especially suitable for arrangements where there are heavy loads in alternating directions, shock loads or heavy static loads.

SKF maintenance-free spherical plain bearings incorporate special sliding layers of advanced materials that have very low friction. They are used in applications where long bearing service life is required without maintenance, or where operating conditions like inadequate lubrication or the absence of any lubricant do not allow the use of steel-on-steel bearings. SKF maintenance-free bearings are produced with three different sliding contact surface combinations, depending on bearing size and series. These sliding contact surface combinations are

- steel/PTFE sintered bronze
- steel/PTFE fabric
- steel/PTFE FRP

### Assortment

The comprehensive SKF assortment comprises radial, angular contact and thrust bearings and covers a shaft diameter range from 4 to 1.000 mm.

### Further information

For detailed information about SKF spherical plain bearings please refer to the

- “SKF Interactive Engineering Catalogue” online at [www.skf.com](http://www.skf.com)
- PUB BU/P1 6116/1 “SKF spherical plain bearings and rod ends”



## SKF rod ends

Rod ends have been designed for use in construction and control rod linkages, for the end of piston rods or the base of pneumatic or hydraulic cylinders. In these applications, tensile and compressive loads must be transmitted at the same time that alignment movements have to be accommodated. A rod end is basically an eye-shaped head with integral shank (the housing) and a self-aligning bearing. Most SKF rod ends incorporate a standard spherical plain bearing that is held in the housing bore by staking both sides or by retaining rings. The wide range of SKF rod ends can accommodate a wide range of operating conditions.

SKF rod ends with steel-on-steel or steel-on-bronze sliding contact surfaces require maintenance. These rod ends generally require periodic relubrication.

The high wear-resistance of steel-on-steel rod ends makes them especially suitable for arrangements where loads alternate direction or where there are relatively heavy static loads. Under these operating conditions but where lubricant starvation may be encountered, steel-on-bronze rod ends are recommended.

SKF maintenance-free rod ends are produced with three different sliding contact surface combinations, depending on size and series. These sliding contact surface combinations are

- steel/PTFE sintered bronze
- steel/PTFE fabric
- steel/PTFE FRP

The sliding layers of modern materials that have very low friction are the same as those used for SKF maintenance-free spherical plain bearings.

## Assortment

The SKF assortment comprises male or female rod ends with right or left-hand thread and also with welding shank. The latter are only available as steel-on-steel rod ends as standard. The assortment covers a pin diameter range between 5 and 200 mm.

## Further information

For detailed information about SKF rod ends please refer to the

- “SKF Interactive Engineering Catalogue” online at [www.skf.com](http://www.skf.com)
- PUB BU/P1 6116/1 “SKF spherical plain bearings and rod ends”.





# Application examples

The unique properties and excellent performance of composite plain bearings have led to their use in a variety of industrial, domestic and other applications. They are particularly suitable for conditions where both maintenance and lubrication are either not required or not possible. Examples of typical existing applications for these bearings are as follows.

## Automotive

King pins, starter pinions, brake rod linkages, brake shafts, brake shoes, suspensions, window lifts, foot pedals, accelerator linkages, fans, propeller shafts, clutch release levers, steering rods, steering columns, swinging arms, shock absorbers, carburettor butterfly valves etc.

## Rail vehicles, railway installations

Automatic doors, level crossing barriers, brakes, pantographs, controllers, load switches, relay boxes, signalling equipment, wagons, points etc.

## Aerospace

Brakes, electronic equipment, undercarriages, engines, radar equipment, control devices etc.

## Construction industry, conveying equipment

Lifts, excavator drives, excavator arms, excavator control equipment, concrete mixers, fork lift trucks, hydraulic rams, chain tensioning sprockets, crane drives, crane control equipment, crane jibs, mortar carriers, pallet lift trucks, pneumatic lifts, caterpillar graders, escalators, moving pavements, vibrating screens, slides, shuttering cleaning machines, low loader trailers, winches, conveyors of all kinds etc.

## Office machines and equipment

Addressing machines, data processing equipment, tape recorders, swiveling chairs, franking machines, copiers, blueprint copiers, drawing tables, drawing machines etc.

## Domestic appliances, hospital equipment

Dental equipment, dishwashers, ironing machines, air conditioning equipment, hospital beds, refrigerators, sewing machines, operating tables, X-ray equipment, vacuum cleaners, washing machines etc.

## Agricultural machines and food-processing machinery

Bottling machines, bakery equipment, timber saws, filtering centrifuges, abattoir and meat processing equipment, hay tedders, potato harvesters, wine-making equipment, loaders, unloaders, combine harvesters, mills, planting machines, root crop harvesters, balers, tractors, tractor seats, automatic packaging equipment, weighing equipment etc.

## General engineering

Chamfering machines, bending machines, machines for sheet metal working, briquetting machines, forge machinery, woodworking machines, plastic moulding machines, presses, automatic welding equipment, machine tools, crushing plants etc.

## Papermaking and textile machines

Cutting machines, printing machines, doubling machines, folding machines, yarn and wool machines, vulcanizing machines, carders, button machines, papermaking and paper-treating machinery, sorting devices, spinning machines, stuffers, knitting machines, looms etc.

## Pumps and valves

Axial and radial piston pumps, metering pumps, firefighting pumps, compressors, ball cocks, mixer valves, oil burners, pumps for chemicals, regulating valves, submersible pumps, vacuum pumps, spur gear pumps etc.

## Electrical equipment

Starting levers for electric motors, contactors, control equipment, switch gear etc.

## Automatic devices and tools

Charging and feeding devices, vending machines, pneumatic tools, hydraulic tools etc.

## Other uses

Refuse disposal equipment and plant, brake magnets, heat treatment plant, blinds, awnings, smelting furnaces, continuously variable gears, drying plant, steel construction etc.

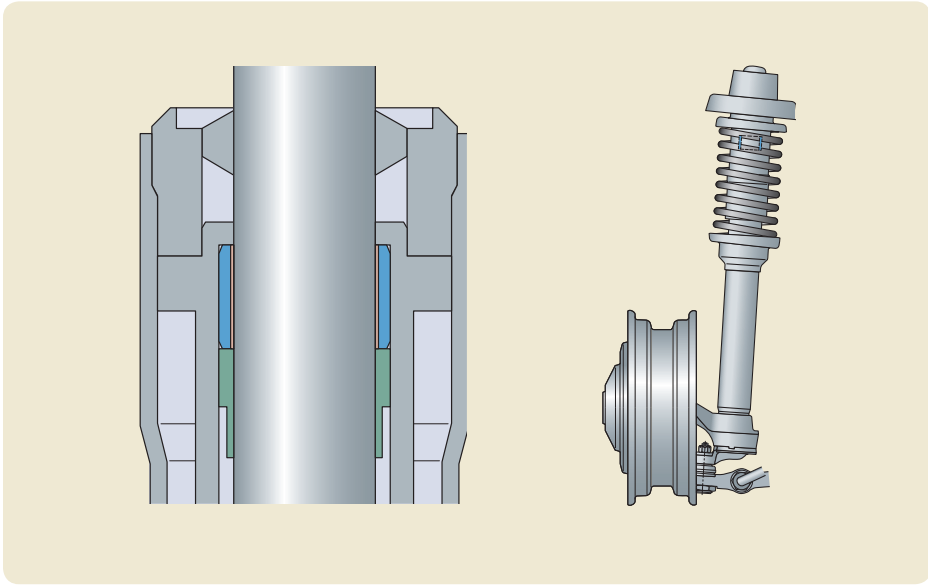

*Linear guide for a car suspension strut piston rod with a PTFE composite straight bushing*

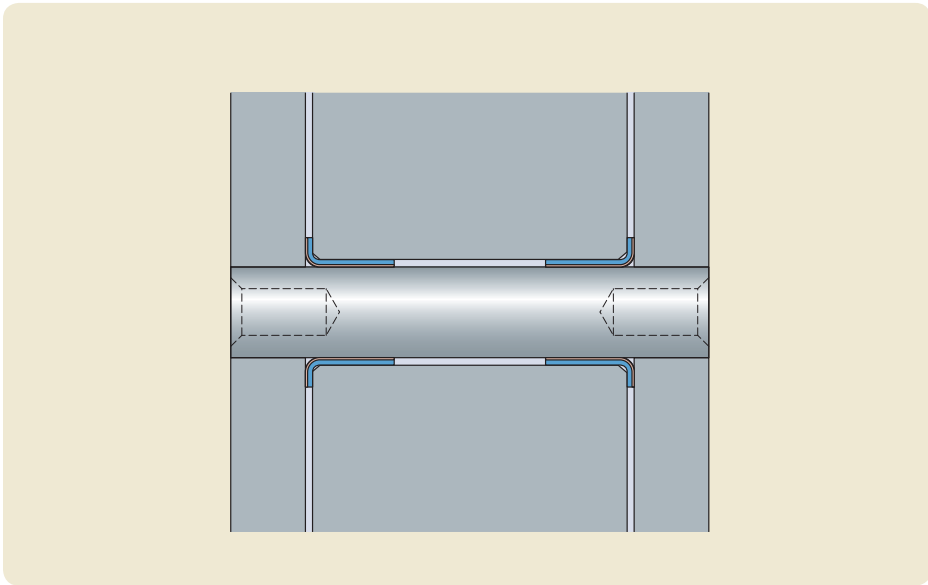

*Bearing arrangement for a sunshade (awning) linkage with flanged PTFE composite bushings*

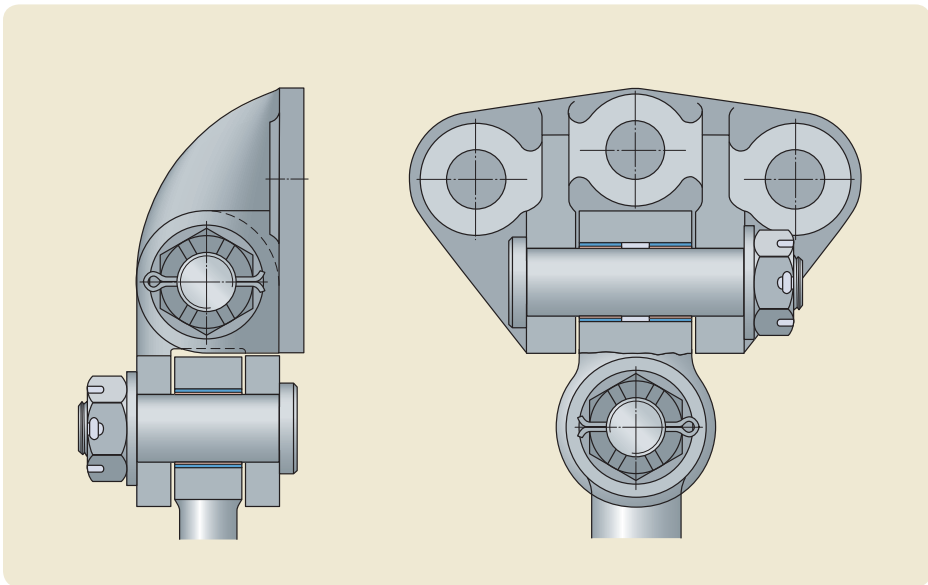

*Bearing arrangement for the leaf spring attachment to the upper linkage of a bogie with PTFE composite straight bushings*

*Linear guide for a continuously variable governor gear pulley with POM composite straight bushings*

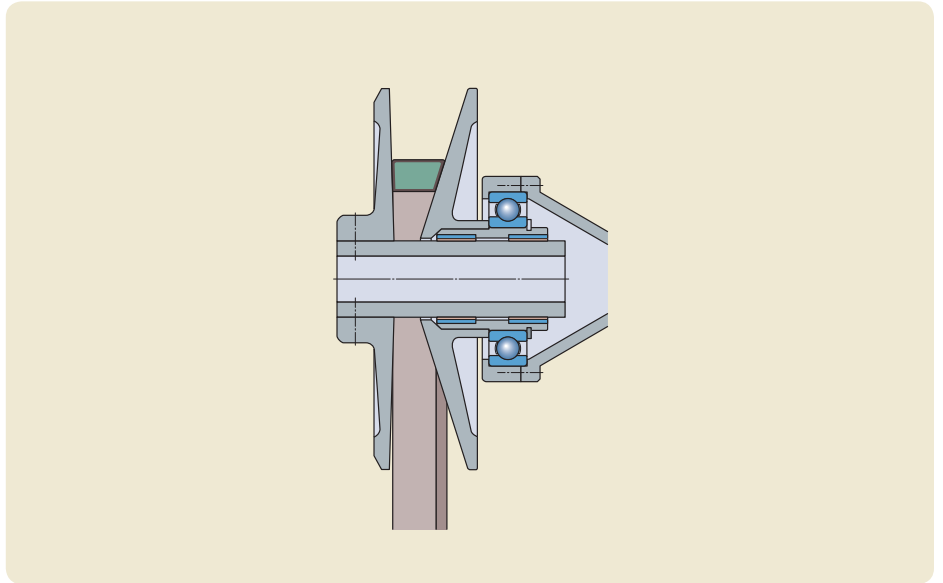

*Linear guide for a hydraulic cylinder piston rod with a POM composite straight bushing*

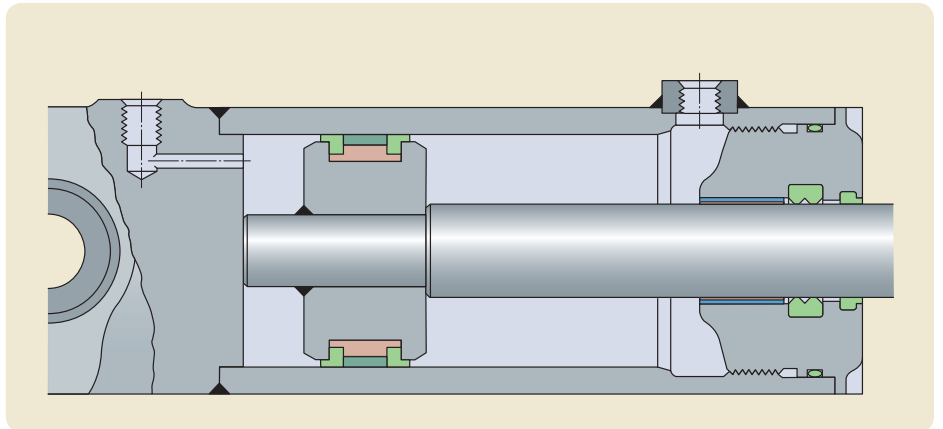

*Bearing arrangement for a geared pump with PTFE composite straight bushings*

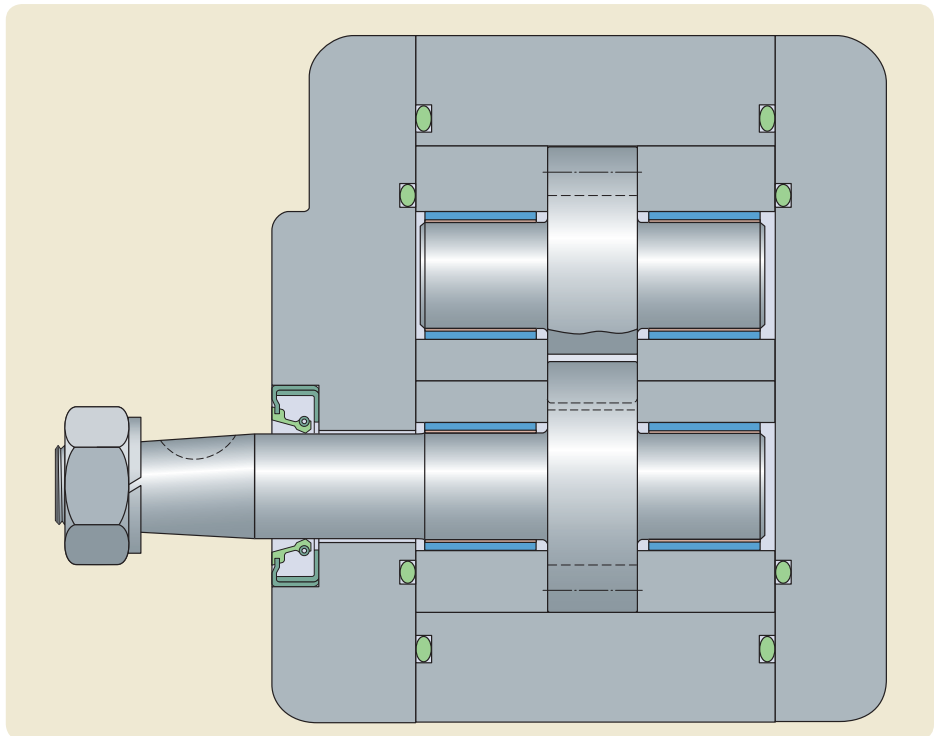

*Bearing arrangement  
for a heavy loader  
trailer steering gear  
shift lever with POM  
composite straight  
bushings*

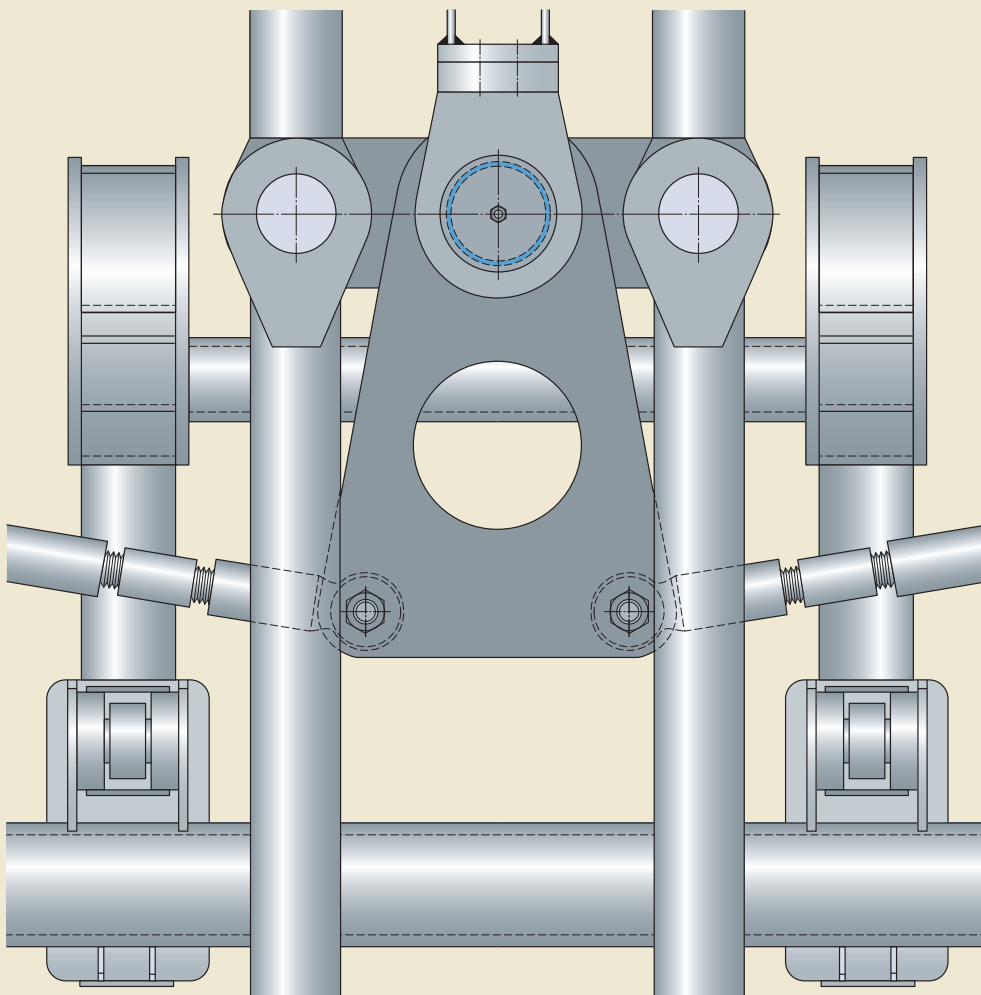
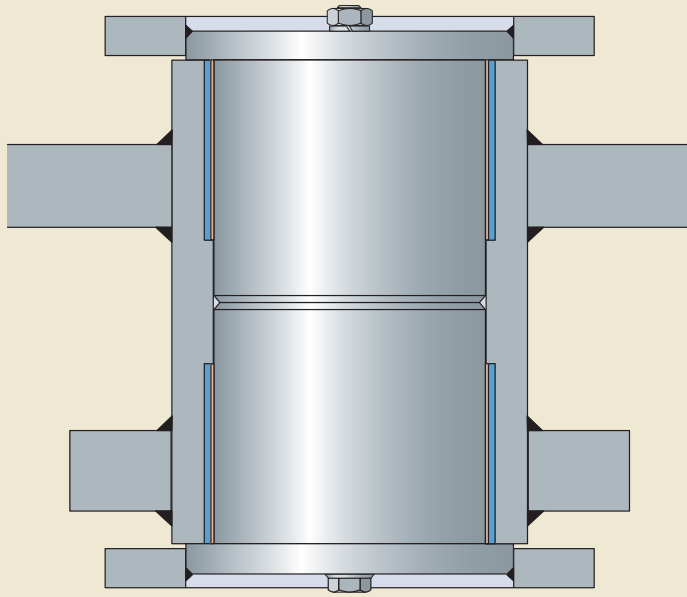

*Bearing arrangement  
for a pallet lift truck  
loading frame coupling  
rod with POM  
composite straight  
bushings*

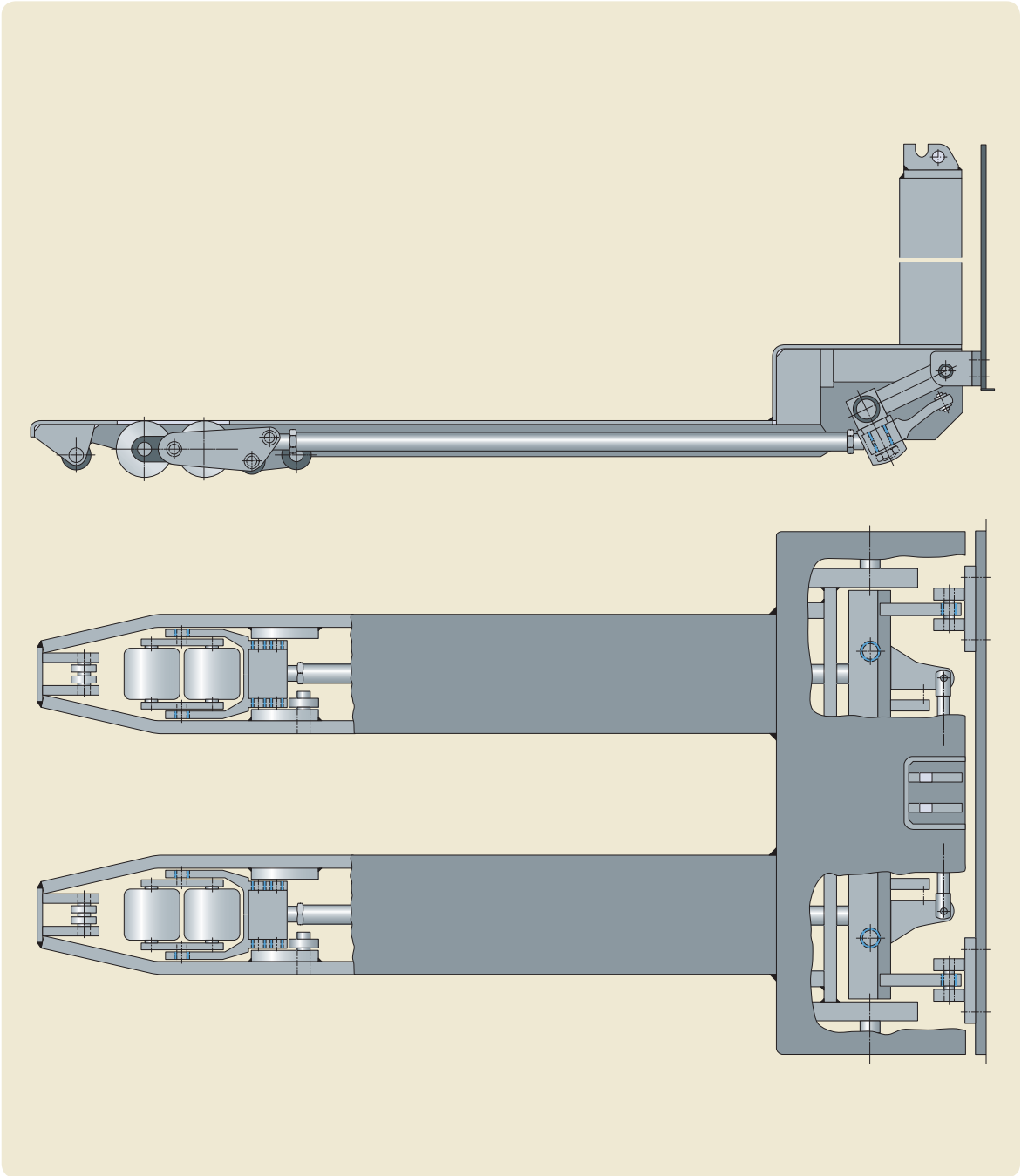

*Bearing arrangement  
for the rotor on  
an underwater pump  
with PTFE composite  
straight bushings*

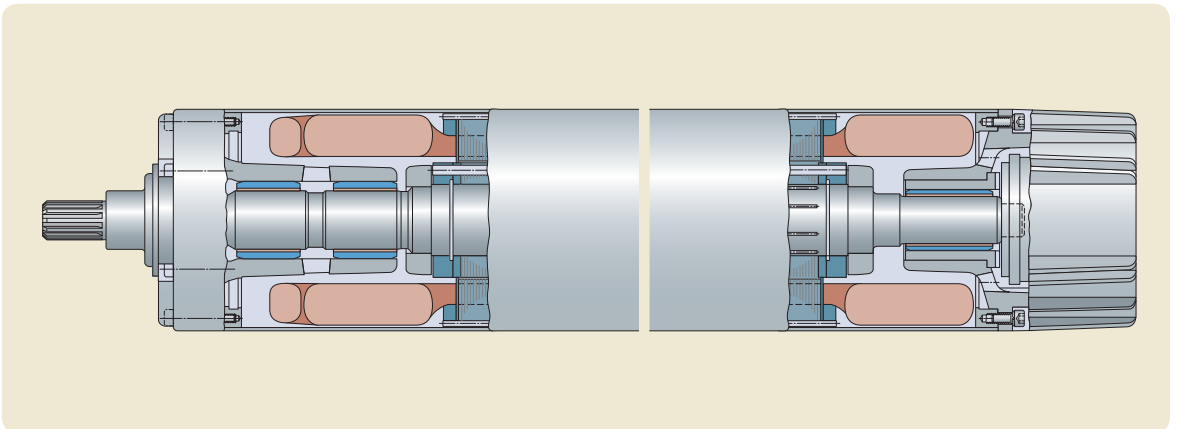

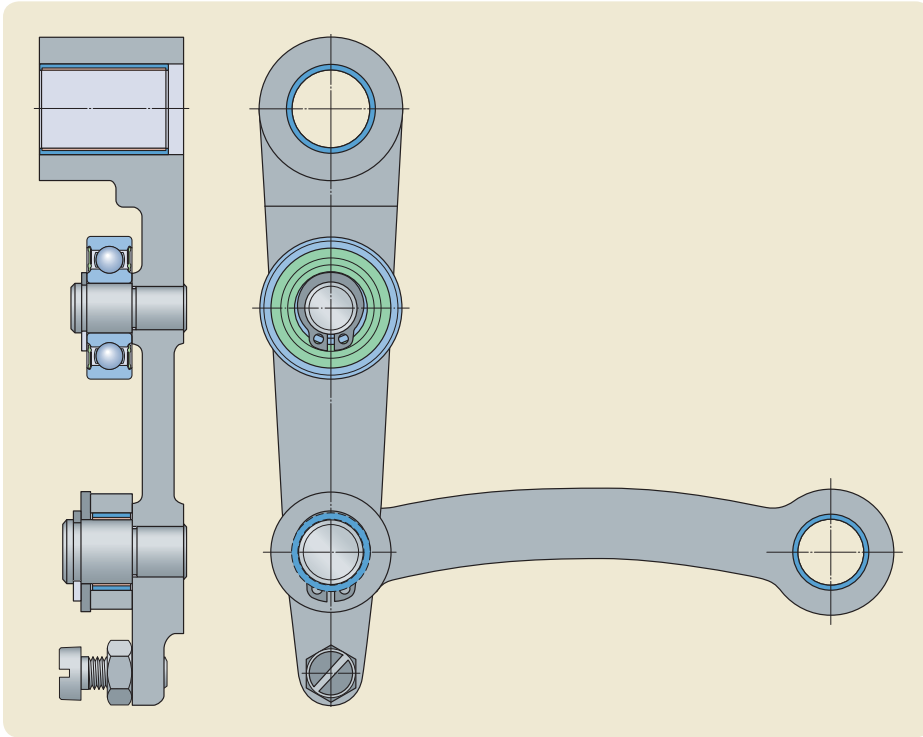

*Coupling rod bearing arrangement for a printing press gear lever with PTFE composite straight bushings*

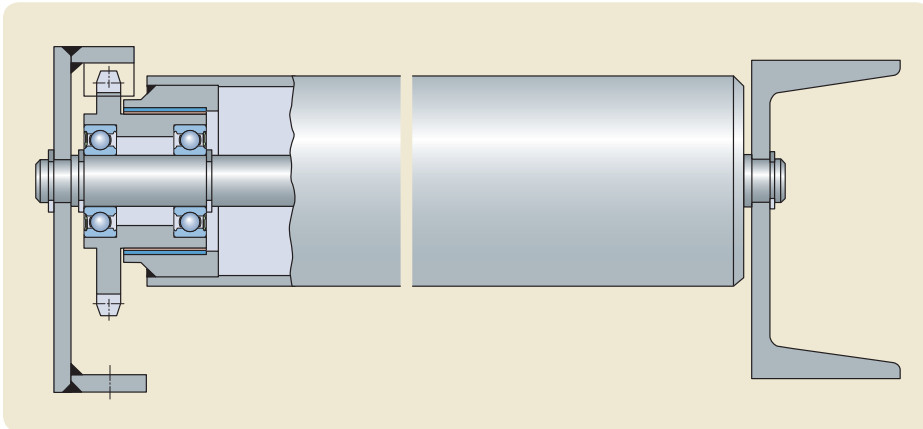

*Bearing arrangement for a conveyor roller with a PTFE composite straight bushing*

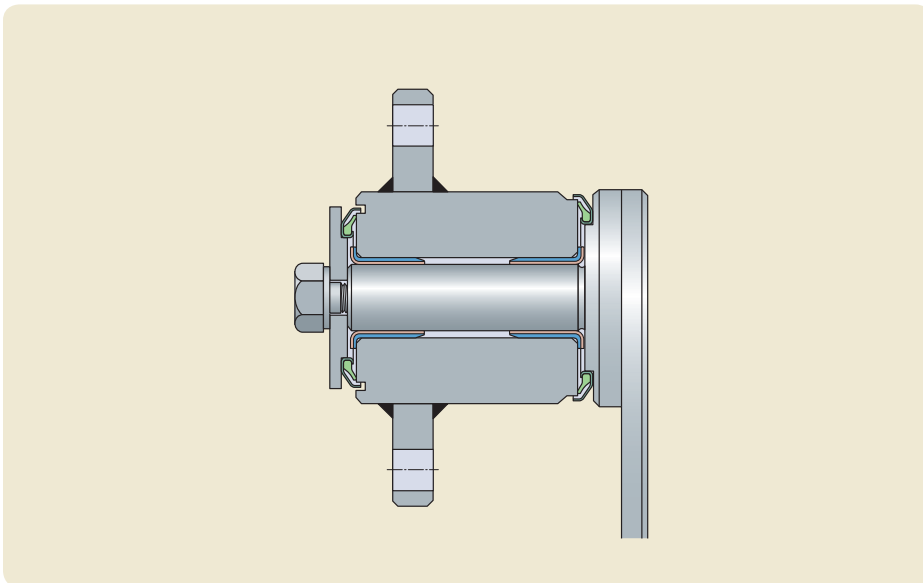

*Bearing arrangement for the cutter on debarking equipment with flanged PTFE composite straight bushings*

*Bearing arrangement for the castors on an airline catering trolley with PTFE composite straight bushings*

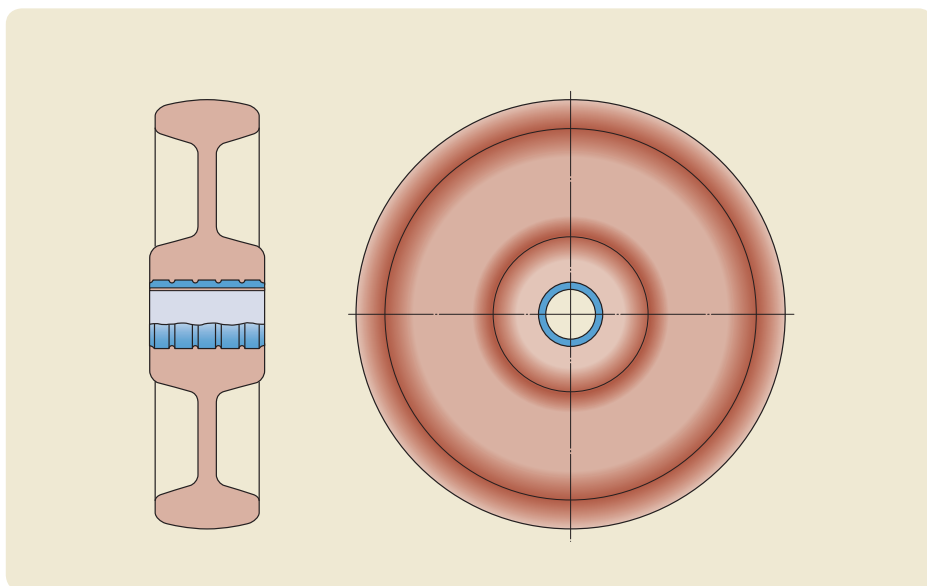

*Swivelling device for a washbasin column with POM composite straight bushings*

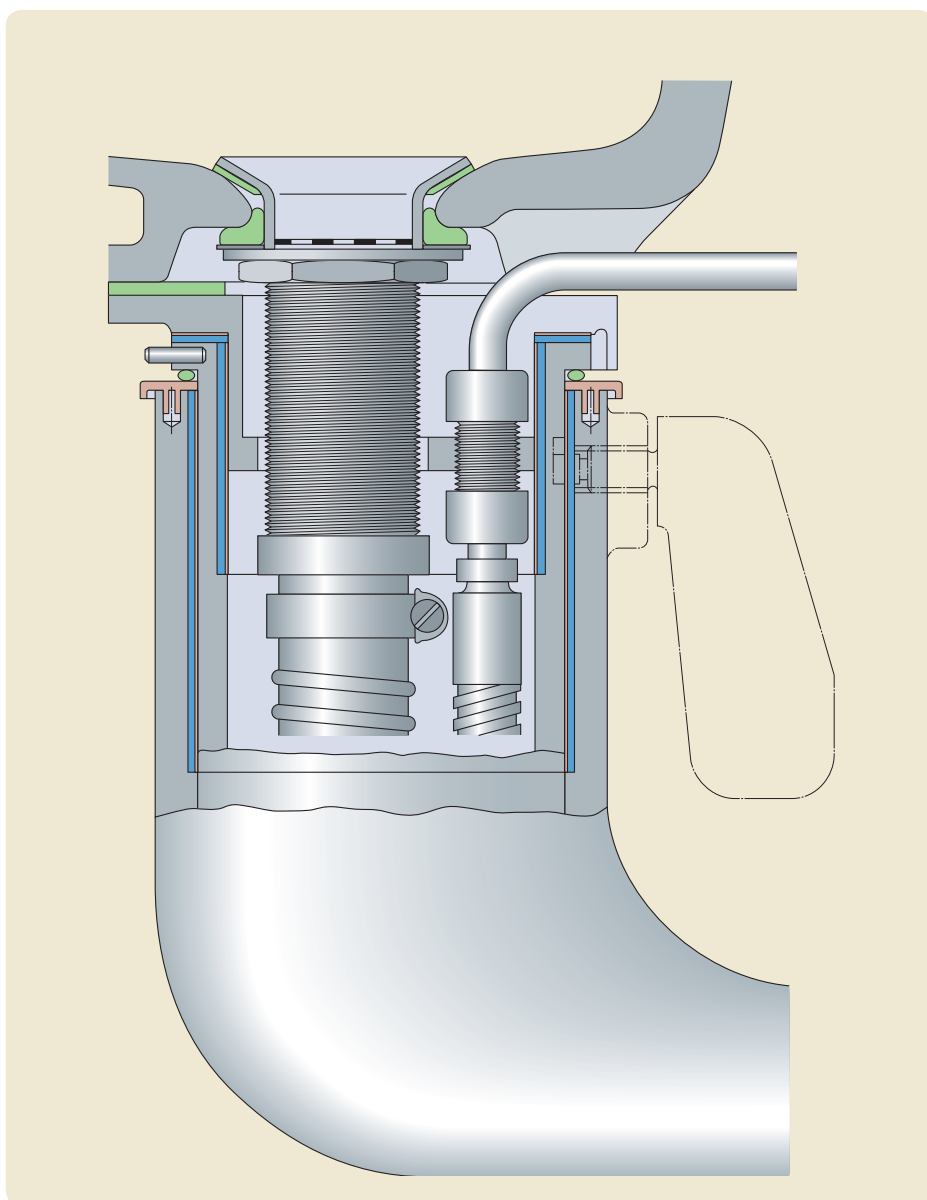

D

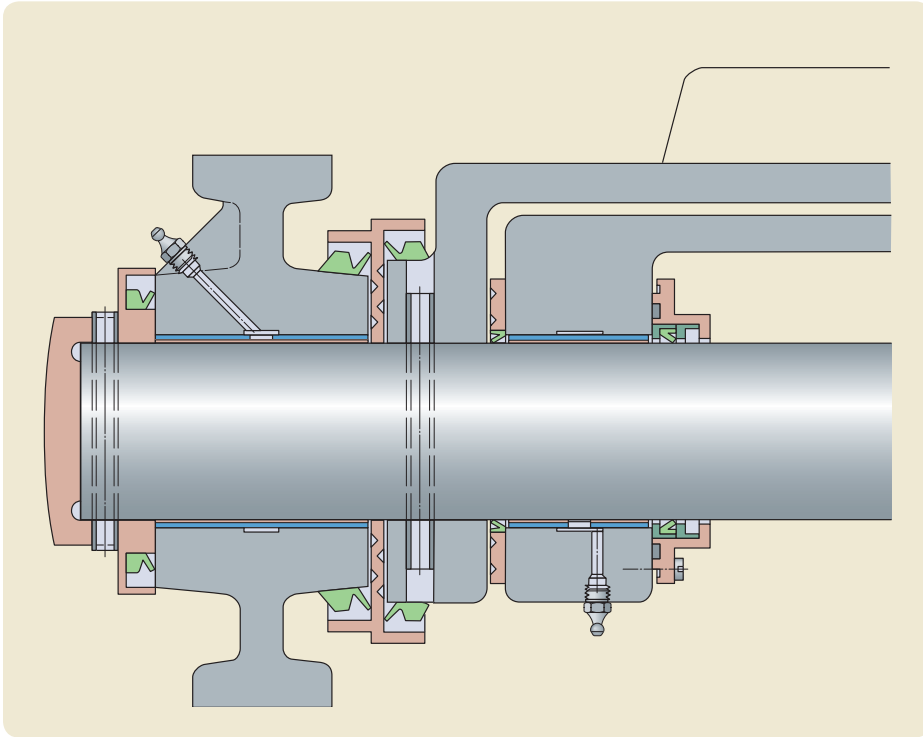

*Bearing arrangement for the platform and side rollers of a platform conveyor with POM composite straight bushings*

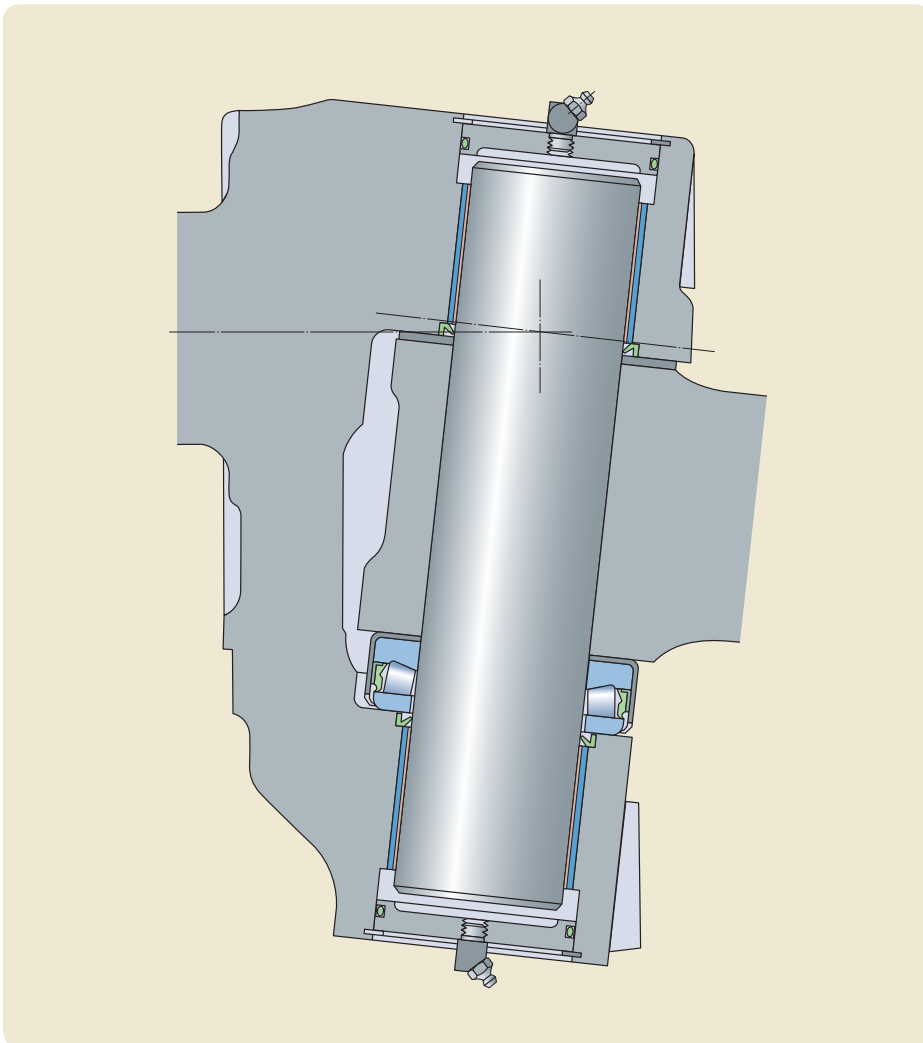

*King pin bearing arrangement with POM composite straight bushings*



*Bearing arrangement for the linear guide of a truck servo steering unit with PTFE composite bushings.*

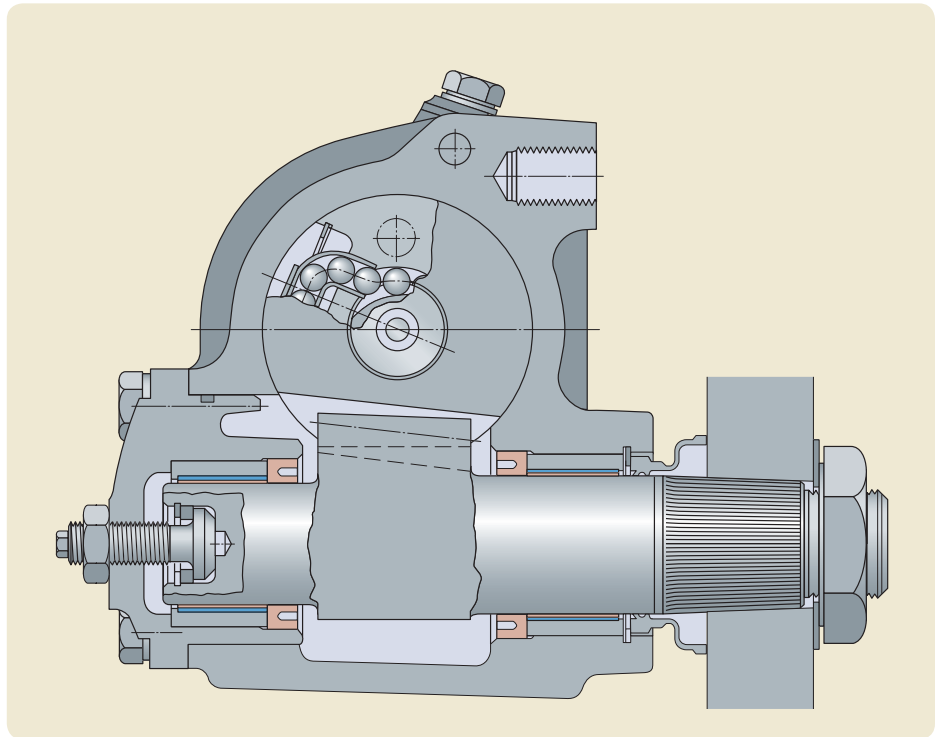

*Bearing arrangement for a lift-off axle with POM composite straight bushings and thrust washers*

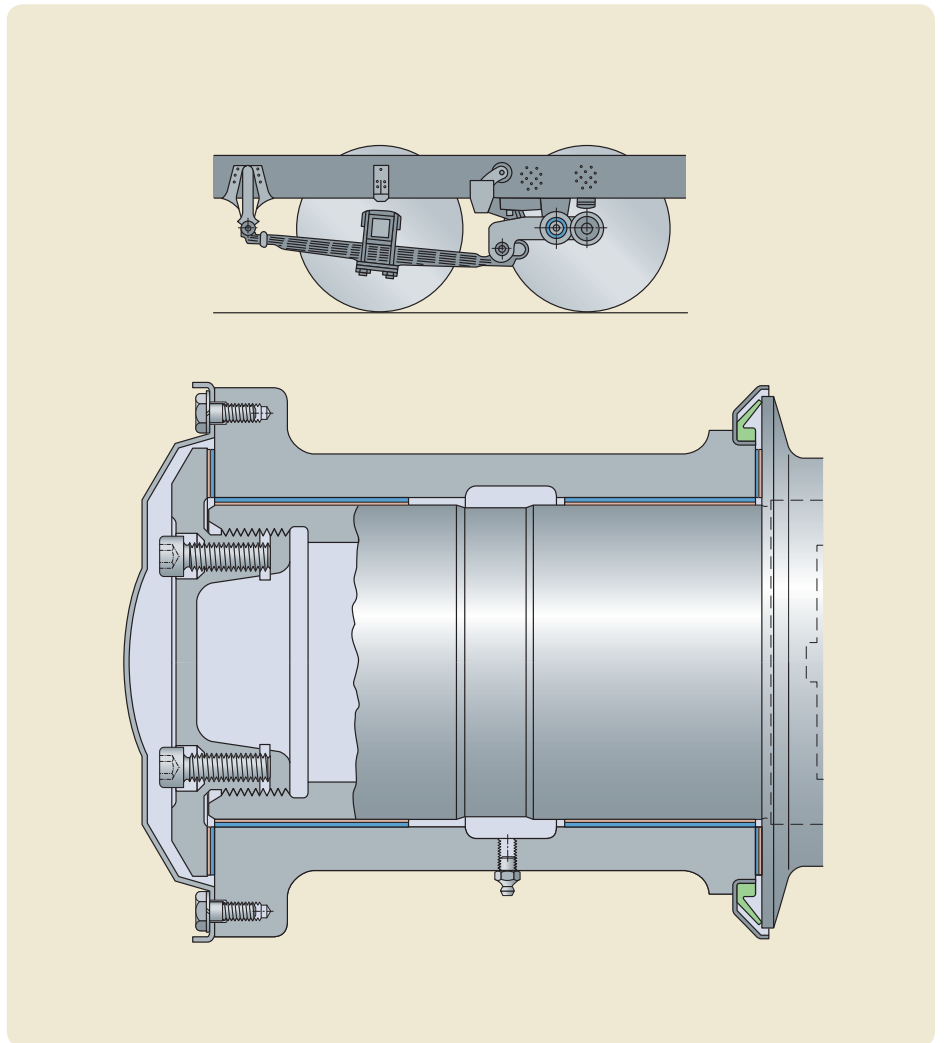

# SKF – the knowledge engineering company

From the company that invented the self-aligning ball bearing more than 100 years ago, SKF has evolved into a knowledge engineering company that is able to draw on five technology platforms to create unique solutions for its customers. These platforms include bearings, bearing units and seals, of course, but extend to other areas including: lubricants and lubrication systems, critical for long bearing life in many applications; mechatronics that combine mechanical and electronics knowledge into systems for more effective linear motion and sensorized solutions; and a full range of services, from design and logistics support to condition monitoring and reliability systems.

Though the scope has broadened, SKF continues to maintain the world's leadership in the design, manufacture and marketing of rolling bearings, as well as complementary products such as radial seals. SKF also holds an increasingly important position in the market for linear motion products, high-precision aerospace bearings, machine tool spindles and plant maintenance services.

The SKF Group is globally certified to ISO 14001, the international standard for environmental management, as well as OHSAS 18001, the health and safety management standard. Individual divisions have been approved for quality certification in accordance with ISO 9001 and other customer specific requirements.

With over 120 manufacturing sites worldwide and sales companies in 70 countries, SKF is a truly international corporation. In addition, our distributors and dealers in some 15 000 locations around the world, an e-business marketplace and a global distribution system put SKF close to customers for the supply of both products and services. In essence, SKF solutions are available wherever and whenever customers need them. Overall, the SKF brand and the corporation are stronger than ever. As the knowledge engineering company, we stand ready to serve you with world-class product competencies, intellectual resources, and the vision to help you succeed.



© Airbus – photo: e'm company, H. Goussé

## **Evolving by-wire technology**

SKF has a unique expertise in the fast-growing by-wire technology, from fly-by-wire, to drive-by-wire, to work-by-wire. SKF pioneered practical fly-by-wire technology and is a close working partner with all aerospace industry leaders. As an example, virtually all aircraft of the Airbus design use SKF by-wire systems for cockpit flight control.

SKF is also a leader in automotive by-wire technology, and has partnered with automotive engineers to develop two concept cars, which employ SKF mechatronics for steering and braking. Further by-wire development has led SKF to produce an all-electric forklift truck, which uses mechatronics rather than hydraulics for all controls.

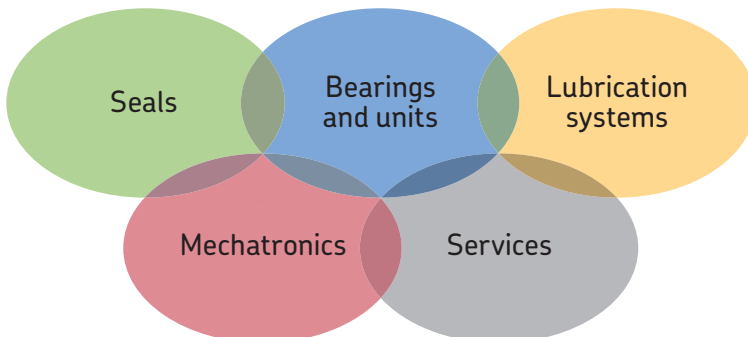



#### **Harnessing wind power**

The growing industry of wind-generated electric power provides a source of clean, green electricity. SKF is working closely with global industry leaders to develop efficient and trouble-free turbines, providing a wide range of large, highly specialized bearings and condition monitoring systems to extend equipment life of wind farms located in even the most remote and inhospitable environments.



#### **Working in extreme environments**

In frigid winters, especially in northern countries, extreme sub-zero temperatures can cause bearings in railway axleboxes to seize due to lubrication starvation. SKF created a new family of synthetic lubricants formulated to retain their lubrication viscosity even at these extreme temperatures. SKF knowledge enables manufacturers and end user customers to overcome the performance issues resulting from extreme temperatures, whether hot or cold. For example, SKF products are at work in diverse environments such as baking ovens and instant freezing in food processing plants.



#### **Developing a cleaner cleaner**

The electric motor and its bearings are the heart of many household appliances. SKF works closely with appliance manufacturers to improve their products' performance, cut costs, reduce weight, and reduce energy consumption. A recent example of this cooperation is a new generation of vacuum cleaners with substantially more suction. SKF knowledge in the area of small bearing technology is also applied to manufacturers of power tools and office equipment.



#### **Maintaining a 350 km/h R&D lab**

In addition to SKF's renowned research and development facilities in Europe and the United States, Formula One car racing provides a unique environment for SKF to push the limits of bearing technology. For over 60 years, SKF products, engineering and knowledge have helped make Scuderia Ferrari a formidable force in F1 racing. (The average racing Ferrari utilizes around 150 SKF components.) Lessons learned here are applied to the products we provide to automakers and the aftermarket worldwide.



#### **Delivering Asset Efficiency Optimization**

Through SKF Reliability Systems, SKF provides a comprehensive range of asset efficiency products and services, from condition monitoring hardware and software to maintenance strategies, engineering assistance and machine reliability programmes. To optimize efficiency and boost productivity, some industrial facilities opt for an Integrated Maintenance Solution, in which SKF delivers all services under one fixed-fee, performance-based contract.



#### **Planning for sustainable growth**

By their very nature, bearings make a positive contribution to the natural environment, enabling machinery to operate more efficiently, consume less power, and require less lubrication. By raising the performance bar for our own products, SKF is enabling a new generation of high-efficiency products and equipment. With an eye to the future and the world we will leave to our children, the SKF Group policy on environment, health and safety, as well as the manufacturing techniques, are planned and implemented to help protect and preserve the earth's limited natural resources. We remain committed to sustainable, environmentally responsible growth.

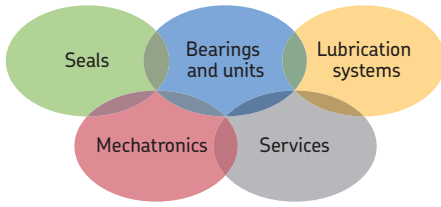

### The Power of Knowledge Engineering

Drawing on five areas of competence and application-specific expertise amassed over more than 100 years, SKF brings innovative solutions to OEMs and production facilities in every major industry worldwide. These five competence areas include bearings and units, seals, lubrication systems, mechatronics (combining mechanics and electronics into intelligent systems), and a wide range of services, from 3-D computer modelling to advanced condition monitoring and reliability and asset management systems. A global presence provides SKF customers uniform quality standards and worldwide product availability.

SKF is a registered trademark of the SKF Group.

© SKF Group 2012

The contents of this publication are the copyright of the publisher and may not be reproduced (even extracts) unless prior written permission is granted. Every care has been taken to ensure the accuracy of the information contained in this publication but no liability can be accepted for any loss or damage whether direct, indirect or consequential arising out of the use of the information contained herein.

PUB BU/P2 11004 EN · October 2012

This publication supersedes publication 6110 EN.

Printed in Sweden on environmentally friendly paper.

