

Filters

For oil
For use in SKF centralized lubrication systems

Standard filter



Disk filter



Return filter



Why filtering?

Solids are diagnosed to be the main cause of damages on the components that are used in lubrication systems. Malfunctions or a shutdown of the machine or system occur if components are damaged by dirt.

Lubrication systems can fail from the following causes:

- Contamination prior to the start-up (e.g. metal chips, paint residues)
- Contamination during the installation (e.g. burr formation, sealing material)
- Contamination in the oil (e.g. residues during production and filling)
- Contamination after the start-up (e.g. wear, oil ageing, water in the oil)

Filters help prevent system or component failures from such causes.

Filters reduce solids and the system can be operated more economically, reliably and maintenance-friendly.



Important information on product usage

All SKF products may be used only for their intended purpose as described in this brochure and in the operating instructions. If operating instructions are supplied together with the products, they must be read and followed.

Not all lubricants can be fed using centralized lubrication systems. SKF can, on request, inspect the suitability of the lubricant selected by the user for pumping in centralized lubrication systems. Lubrication systems and their components manufactured by SKF are not approved for use in conjunction with gases, liquefied gases, pressurized gases in solution, vapors or such fluids whose vapor pressure exceeds normal atmospheric pressure (1013 mbar) by more than 0.5 bar at their maximum permissible temperature.

In particular, we call your attention to the fact that hazardous materials of any kind, especially the materials classified as hazardous by EC Directive 67/548/EEC, Article 2, Para. 2, may only be filled into SKF centralized lubrication systems and components and delivered and/or distributed with the same after consultation with and written approval from SKF.

Table of contents

Standard filters DIN 24550	4
General	4
Characteristics	5
Filter mount	5
Pressure filter as per DIN 24550, complete	6
Dirt indicators	7
Examples for standard filters, complete	8
Filter elements/filter housings	10
Double changeover filters as per DIN 24550, complete	11
Screen filters	12/13
Suction strainers	13
Disk filters	14/15
Return filters	16/17
Venting filters	18

Filter

Standard filters DIN 24550

General

Filter design

The pressure filters are standard filters according to DIN 24550. They are modular in design.

They consist of a filter housing (filter head/ filter body) (fig. 1), a filter element (fig. 2) and a screw plug (fig. 4). Optionally a dirt indicator (fig. 3) can be selected instead of the screw plug. In the standard design, the filters are delivered with a screw plug.

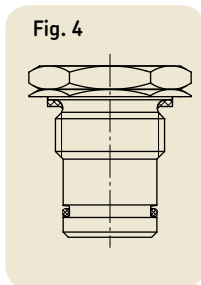
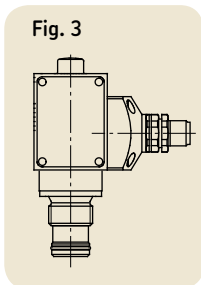
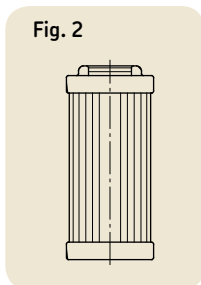
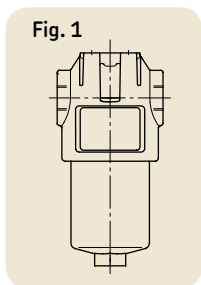

Filter installation

The pressure filters are used as line filters in the pipes of the lubrication system for separating solids from the fluids. This increases the service life of the system's components and minimizes the chance of system failure. When arranging the filter on the container or in the system, make sure that the filters are easily accessible and that the filter cartridges can be easily replaced. Strictly adhere to the installation height (technical drawing starting from page 10). Otherwise the change of the filter cartridge cannot be ensured. The mounting position is vertical.

Filter housing

The housings are used to accommodate the filter element and are available in various designs and nominal dimensions (NG 40; NG 63; NG 100)

- without reverse flow valves
- with 2 reverse flow valves

Filters with two reverse flow valves can be flushed in both directions. Filtering takes place only in one direction. Function: Fluid flows from A to B, necessarily via the filter element. The flow from B to A does not take place via the filter element, because the first check valve will close. The second valve opens in direction A.

Filter element see table 2 (page 6)

The filter element removes the solids from the lubricant.

- Filter element in star crimp (high dirt retention)
- Flow direction from the outside to the inside

1. Fiberglass fleece – disposable elements based on inorganic fibers/ absolute filtration

- Application: max. allow. Δp on element 30 bars
- Protection against element damage
- Collapse pressure resistance 20 bars

2. Wire fabric/nominal filtration

- High permissible temperature range
- Cleanable
- Collapse pressure resistance 30 bars

Dirt indicators

see table 3 (page 7)

The dirt indicator monitors the filter element and signals when it needs to be replaced.

- electrical/optical/M12x1/NO-contact-NC contact (75%/100%)
- electrical/M12x1/NO-contact-NC contact (75%/100%)/LED/cold start suppression
- electrical/optical/M12x1/NC contact (75%/100%)
- electrical/M12x1/NO-contact-NC contact (75%/100%)/LED
- optical
- electrical DIN EN 175301-803-A (DIN 43650)/changeover contact
- The response pressure of the dirt indicators is $\Delta p = 5$ bars.

Filter maintenance

The dirt indicator displays when the next filter maintenance is due. Proper maintenance helps to maximize utilization of filter elements.

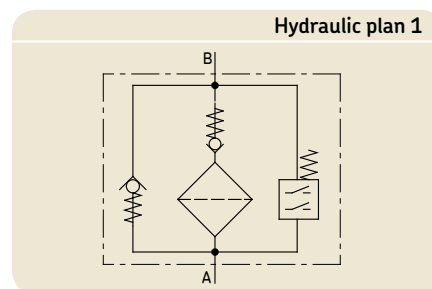

Accessories

Connecting pieces, see brochure **1-0103-EN**.

Repair kit **995-901-056** consisting of various FKM (FPM) seals..

Filter

Standard filters DIN 24550

Technical data

Characteristics

Temperature range	-30 °C to +100 °C
Mounting position	Vertical, make certain the direction of flow is correct.
Connections acc. to ISO 228	G 1/2
Volumetric flow up to	40 liters 63 liters 100 liters
Pressure stage	100 bars

Compatibility with fluids..... Mineral oils, difficultly inflammable and water-containing fluids, rapidly biodegradable fluids

Material

Housing, cpl.	Aluminum
Gasket.	FKM (FPM)
Filtermaterial	Fiberglass fleece – inorganic fiber – absolute filtration Wire fabric – stainless steel – nominal filtration

Filter mount

Table 1

Designation	Order No.
Mounting bracket for 3-liter plastic and metal reservoir	881-280-050
Retaining plate for 6-liter plastic reservoir	881-280-044
Filter plate for 6-liter metal reservoir	881-290-270
Filter plate for 15-liter metal reservoir	881-290-271
Filter plate for 30-liter metal reservoir	881-290-272
Filter plate for 50-liter metal reservoir	881-290-273

Fig. 5

Mounting bracket 881-280-050

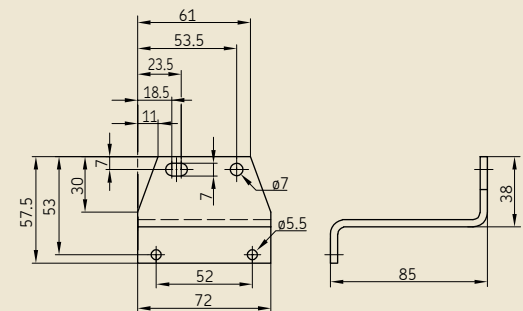

Fig. 6

Retaining plate 881-280-044

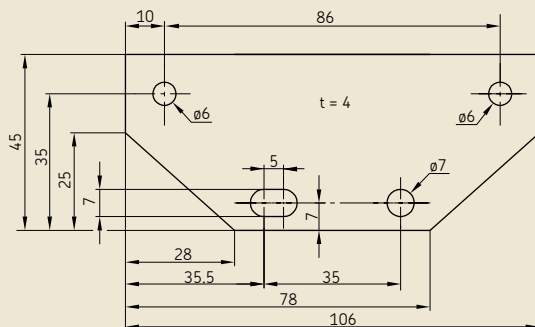
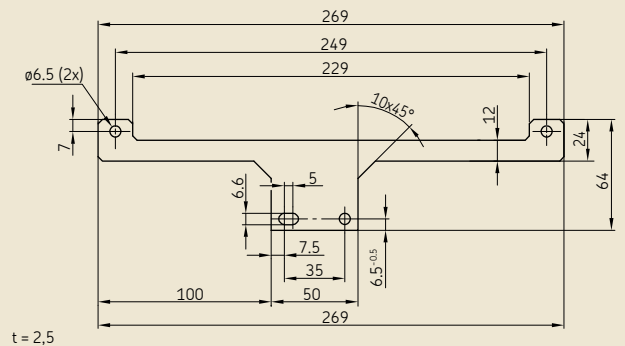

Fig. 7

Filter plate 881-290-270



1-0116-EN

Pressure filter DIN 24550

Selection table

Table 2

Standard filter, kpl. Order No.	Filter fig. no.	NG	Element 1) Order No.	Filter rating [µm]	Dirt retention or filter area ISO 16889/ at Δp = 5 bars	Filter element	Reverse flow valve 3) (2×)	Dirt dispaty 1) 2) Order No.	Dim. draw.	Housing Order No.
169-460-077	16	40	169-400-260-V57	3	5.2 g	Fiberglass fleece	with	176-200-014	11	853-880-010
169-460-099-V57	14	63	169-400-257	3	9.2 g	Fiberglass fleece	with	176-200-009	9	853-880-014
169-460-135	15	63	169-400-257	3	9.2 g	Fiberglass fleece	with	176-200-012	10	853-880-014
169-460-260-V57	14	40	169-400-260-V57	3	5.2 g	Fiberglass fleece	with	176-200-009	9	853-880-010
169-460-260-V64	14	40	169-400-260-V57	3	5.2 g	Fiberglass fleece	with	176-200-009	9	853-880-010
169-460-261	15	40	169-400-260-V57	3	5.2 g	Fiberglass fleece	without	176-200-012	10	853-880-011
169-460-269	13	40	169-400-260-V57	3	5.2 g	Fiberglass fleece	without	833-030-014	8	853-880-011
169-460-273	17	40	169-400-260-V57	3	5.2 g	Fiberglass fleece	without	176-200-013	12	853-880-011
169-460-275	14	40	169-400-260-V57	3	5.2 g	Fiberglass fleece	with	176-200-011	9	853-880-010
169-460-279	16	40	169-400-260-V57	3	5.2 g	Fiberglass fleece	without	176-200-014	11	853-880-011
169-460-280	14	40	169-400-260-V57	3	5.2 g	Fiberglass fleece	without	176-200-011	9	853-880-011
169-460-283	15	40	169-400-260-V57	3	5.2 g	Fiberglass fleece	with	176-200-012	10	853-880-010
169-460-080	15	63	169-400-252	10	11.1 g	Fiberglass fleece	with	176-200-012	10	853-880-014
169-460-087-V57	14	40	169-400-250	10	6.3 g	Fiberglass fleece	with	176-200-009	9	853-880-010
169-460-087-V64	14	40	169-400-250	10	6.3 g	Fiberglass fleece	with	176-200-009	9	853-880-010
169-460-087-V70	14	40	169-400-250	10	6.3 g	Fiberglass fleece	with	176-200-009	9	853-880-010
169-460-155	14	40	169-400-250	10	6.3 g	Fiberglass fleece	with	176-200-011	9	853-880-010
169-460-250	13	40	169-400-250	10	6.3 g	Fiberglass fleece	with	833-030-014	8	853-880-010
169-460-251	17	40	169-400-250	10	6.3 g	Fiberglass fleece	with	176-200-013	12	853-880-010
169-460-252	16	40	169-400-250	10	6.3 g	Fiberglass fleece	with	176-200-014	11	853-880-010
169-460-262	15	40	169-400-250	10	6.3 g	Fiberglass fleece	without	176-200-012	10	853-880-011
169-460-264	15	63	169-400-252	10	11.1 g	Fiberglass fleece	without	176-200-012	10	853-880-012
169-460-266	15	100	169-400-254	10	18.6 g	Fiberglass fleece	without	176-200-012	10	853-880-013
169-460-270	13	40	169-400-250	10	6.3 g	Fiberglass fleece	without	833-030-014	8	853-880-011
169-460-274	17	40	169-400-250	10	6.3 g	Fiberglass fleece	without	176-200-013	12	853-880-011
169-460-277	14	40	169-400-250	10	6.3 g	Fiberglass fleece	with	176-200-009	9	853-880-010
169-460-277-V64	14	40	169-400-250	10	6.3 g	Fiberglass fleece	with	176-200-009	9	853-880-010
169-460-287	16	63	169-400-252	10	11.1 g	Fiberglass fleece	without	176-200-014	11	853-880-012
169-460-286	17	63	169-400-286	20	–	Fiberglass fleece	without	176-200-013	12	853-880-012
169-460-185	14	40	169-400-185-V57	25	440 m ²	Wire fabric	with	176-200-009	9	853-880-010
169-460-185-V57	14	40	169-400-185-V57	25	440 m ²	Wire fabric	with	176-200-009	9	853-880-010
169-460-253	13	40	169-400-185-V57	25	440 m ²	Wire fabric	with	833-030-014	8	853-880-010
169-460-254	17	40	169-400-185-V57	25	440 m ²	Wire fabric	with	176-200-013	12	853-880-010
169-460-255	14	40	169-400-255	25	7 g	Fiberglass fleece	with	176-200-011	9	853-880-010
169-460-263	15	40	169-400-255	25	7 g	Fiberglass fleece	without	176-200-012	10	853-880-011
169-460-265	15	63	169-400-253	25	12.8 g	Fiberglass fleece	without	176-200-012	10	853-880-012
169-460-267	15	100	169-400-256	25	20.6 g	Fiberglass fleece	without	176-200-012	10	853-880-013
169-460-268	16	40	169-400-185-V57	25	440 m ²	Wire fabric	with	176-200-014	11	853-880-010
169-460-271	13	40	169-400-255	25	7 g	Fiberglass fleece	without	833-030-014	8	853-880-011
169-460-276	15	40	169-400-255	25	7 g	Fiberglass fleece	without	176-200-010	10	853-880-011
169-460-278	17	40	169-400-255	25	7 g	Fiberglass fleece	without	176-200-013	12	853-880-011
169-460-281	15	40	169-400-185-V57	25	440 m ²	Wire fabric	with	176-200-012	10	853-880-010
169-460-284	13	40	169-400-185-V57	25	440 m ²	Wire fabric	without	833-030-014	8	853-880-011
169-460-288	15	63	169-400-253	25	12.8 g	Fiberglass fleece	without	176-200-010	10	853-880-012
169-460-256	13	40	169-400-251	50	440 m ²	Wire fabric	with	833-030-014	8	853-880-010
169-460-257	17	40	169-400-251	50	440 m ²	Wire fabric	with	176-200-013	12	853-880-010
169-460-258	16	40	169-400-251	50	440 m ²	Wire fabric	with	176-200-014	11	853-880-010
169-460-259	13	40	169-400-251	50	440 m ²	Wire fabric	without	833-030-014	8	853-880-011
169-460-272	17	40	169-400-251	50	440 m ²	Wire fabric	without	176-200-013	12	853-880-011
169-460-282	14	40	169-400-251	50	440 m ²	Wire fabric	without	176-200-009	9	853-880-011

Fittings according ISO 228: G^{1/2}
Pressure filter without by-pass

Dirt indicators

Table 3

Order No.	Dim. draw.	Indication ¹⁾	Switching type	Electrical connection ²⁾	Switching points
176-200-009	9	Electrical/Optical	1× NO-contact / 1× NC-contact	M12×1 / 4-pin	75% / 100%
176-200-010	10	Electrical/Optical	1× NO-contact / 1× NC-contact	M12×1 / 4-pin / LED- Cold start suppression 30°C	75% / 100%
176-200-011	9	Electrical/Optical	2× NC-contact	M12×1 / 4-pin	75% / 100%
176-200-012	10	Electrical/Optical	1× NO-contact / 1× NC-contact	M12×1 / 4-pin / LED	75% / 100%
176-200-013	12	Optical			
176-200-014	11	Electrical	Changeover contact	DIN EN 175301-803-A	
Screw plug					
833-030-014	8				

Opening pressure: $\Delta p = 5$ bars

Fig. 8

Screw plug

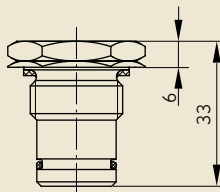

Fig. 9

Electrical/Optical

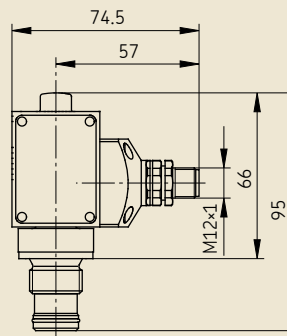

Fig. 10

Electrical – with LED

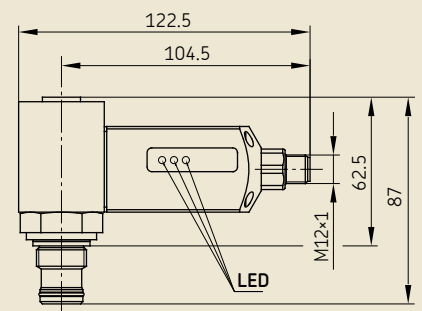

Fig. 11

Electrical

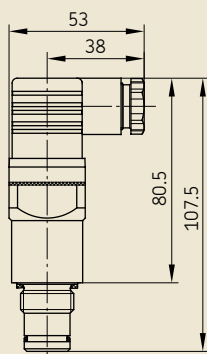
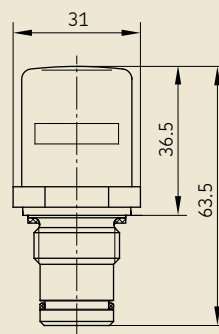
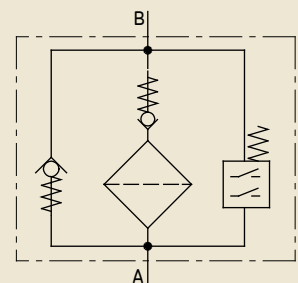

Fig. 12

Optical



Hydraulic plan 2



¹⁾ Other filter housings (e.g. with by-pass), filter elements (e.g. stainless steel) and dirt indicator (e.g. opening pressure at 2 bars) on request.

²⁾ The cold start suppression prevents an activation of the dirt indicator when temperatures fall below 30 °C.

³⁾ Filters with two reverse flow valves can be flushed in both directions.

Filtering takes place only in one direction.

Function: Fluid flows from A to B, necessarily via the filter element.

The flow from B to A does not take place via the filter element, because the first check valve will close.

The second valve opens in direction A.

Standard filters

Examples, complete

Fig. 13

With screw plug

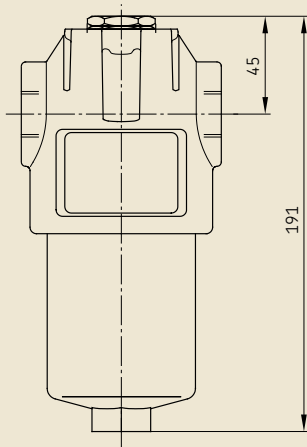

Fig. 14

With electrical/optical dirt indicator

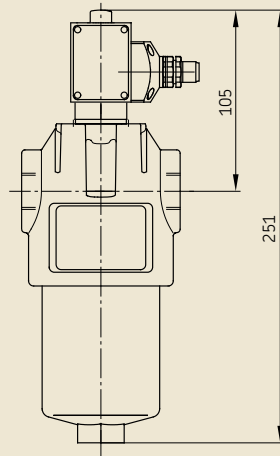
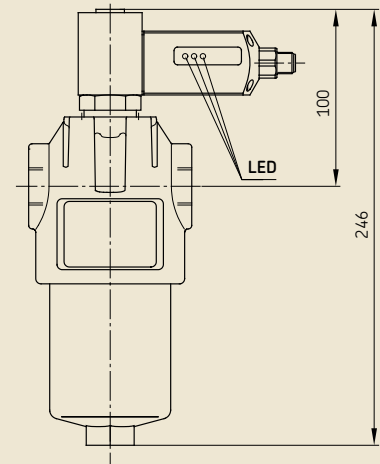

Fig. 15

With electrical/optical dirt indicator



Order No.

169-460-269
169-460-250
169-460-270
169-460-253
169-460-271
169-460-284
169-460-256
169-460-259

Screw plug
833-030-014

Hydraulic plan 3

with reverse flow valve

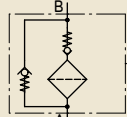

Hydraulic plan 4

without reverse flow valve



Order No.

169-460-099-V57
169-460-260-V57
169-460-087-V57
169-460-277
169-460-277-V64
169-460-185
169-460-185-V57
169-460-282

169-460-275
169-460-280
169-460-155
169-460-255

Hydraulic plan 5

with reverse flow valve

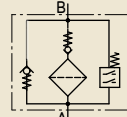

Hydraulic plan 6

without reverse flow valve

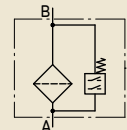

Order No.

169-460-276
169-460-288

169-460-135
169-460-261
169-460-080
169-460-262
169-460-264
169-460-266
169-460-263
169-460-265
169-460-267
169-460-281

Hydraulic plan 7

with reverse flow valve

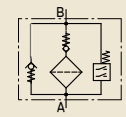

Hydraulic plan 8

without reverse flow valve

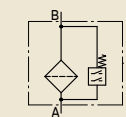

Wiring diagram 1

Dirt indicator

176-200-009 – NO-contact – NC-contact – M12×1

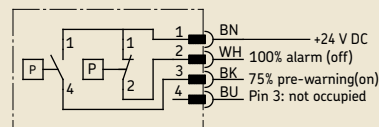

Wiring diagram 2

Dirt indicator

176-200-010 – NO-contact – NC-contact – M12×1
Cold start suppression

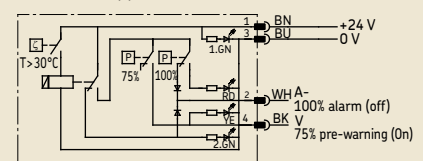

Wiring diagram 3

Dirt indicator

176-200-011 – 2× NC-contact – M12×1

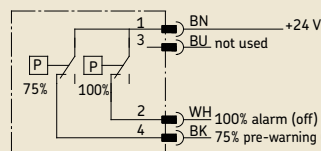

Wiring diagram 4

Dirt indicator

176-200-012 – NO-contact – NC-contact – M12×1

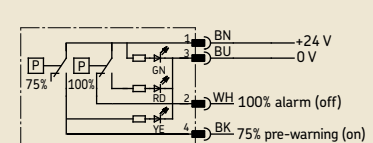

Standard filters

Examples, complete

Fig. 16

With electrical dirt indicator

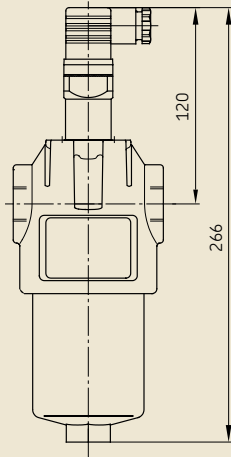
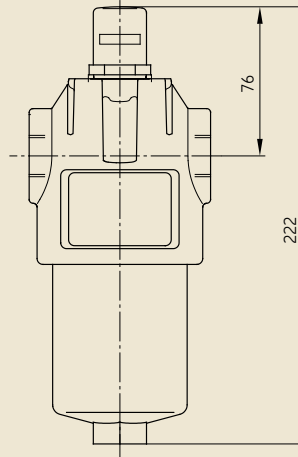

Fig. 17

With optical dirt indicator



Order No.

- 169-460-077
- 169-460-279
- 169-460-269
- 169-460-258
- 169-460-254
- 169-460-287

Hydraulic plan 9

with reverse flow valve

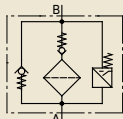

Hydraulikplan 10

without reverse flow valve

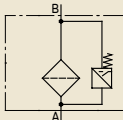

Order No.

- 169-460-273
- 169-460-251
- 169-460-274
- 169-460-278
- 169-460-257
- 169-460-272
- 169-460-286

Hydraulic plan 11

with reverse flow valve

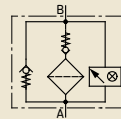

Hydraulikplan 12

without reverse flow valve

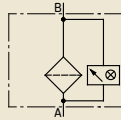

Wiring diagram 5

Dirt indicator

176-200-014 – DIN EN 175301-803-A

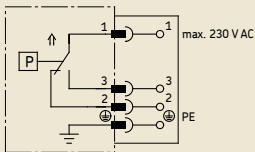

Filter elements and filter housing

Filter elements ¹⁾

Filter elements are available in different nominal dimensions (NG) and filter ratings

Filter elements

- 3 µm:
169-400-260-V57 NG 40
169-400-257 NG 63
- 10 µm:
169-400-250 NG 40
169-400-252 NG 63
- 169-400-254 NG 100
- 20 µm:
169-400-286 NG 63
- 25 µm:
169-400-185-V57 NG 40
169-400-253 NG 63
169-400-255 NG 40
169-400-256 NG 100
- 50 µm:
169-400-251 NG 40

Fig. 18

Filter elements

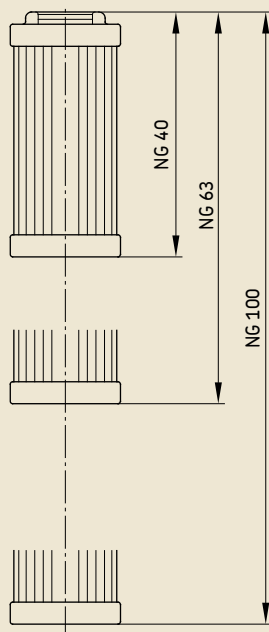

Filter housing ¹⁾

Filter housings are available in different nominal dimensions (NG) and with/without reverse flow valves:

Filter housing

- with 2× reverse flow valve:
853-880-010 NG 40
- 853-880-014 NG 63
- without reverse flow valve:
853-880-011 NG 40
853-880-012 NG 63
853-880-013 NG 100

Fig. 19

Filter housing

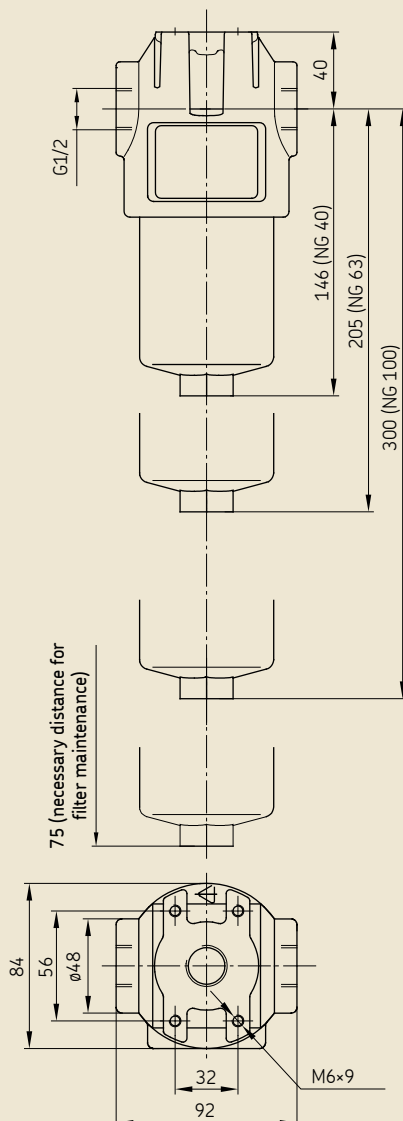

¹⁾ Other filter housings (e.g. with by-pass), filter elements (e.g. stainless steel) and dirt indicator (e.g. opening pressure at 2 bars) on request.

Screen filters



These filters should be used preferably in the delivery (discharge) lines for intermittently operated, centralized lubrication systems.

To clean the screen filter element, the hexagon screw (SW 13) must be unscrewed. The filter element can then be pulled out without loosening the tubing.

Approximately 40 mm space below is required for the cleaning of the filter element.

Table 5

Screen filter Order No.	Dim. draw.	Element Order No.	Filter rating [µm]	Filter element material	Reverse flow valve [bar]	Hydraulic plan	Mesh-width [mm]	Screen area [cm ²]	Flow rate volume [l/min]	Operating pressure max. [bar]	Dirt indicator Order No.	Connections
213-870	21	213-870.U1	63	Wire fabric	without	14	0,063	21	2 ²⁾	60	without	G 1/4
213-870F *)	21	213-870.U2	160	Wire fabric	without	14	0,160	20	–	60	without	G 1/4
213-880	21	213-880.U1	25	Wire fabric	without	14	0,025	21	2	60	without	G 1/4
213-890	21	213-890.U1	320	Wire fabric	without	14	0,320	21	2	60	without	G 1/4
213-900	22	213-880.U1	25	Wire fabric	0.1	15	0,025	21	2 ¹⁾	45	without	M14×1.5
213-910 **)	22	213-910.U1	25	Wire fabric	without	14	0,025	20	–	60	without	G 1/4
213-920	21	213-920.U1	3	Filter fabric	without	14	0,003	21	2 ¹⁾	60	without	G 1/4
213-930F	–	213-870.U2	160	Wire fabric	0.1	15	0,160	21	2 ¹⁾	45	without	G 1/4
213-940	23	213-920.U1	3	Filter fabric	without	14	0,003	21	2 ¹⁾	60	176-200-004	G 1/4
213-950F	–	213-870.U2	160	Wire fabric	without	14	0,160	20	2	60	without	2× G 1/2 2× G 1/2

*) for grease, NLGI grades 000 and 00

**) for grease, NLGI grade 000

¹⁾ At an operating viscosity of the flow medium of 100 mm²/s, a pressure loss of 0.38 bar and a clean filter.

²⁾ At an operating viscosity of the flow medium of 370 mm²/s, a pressure loss of 0.5 bar and a clean filter.

Accessories

Connecting pieces, see brochure **1-0103-EN**.

Fig. 21

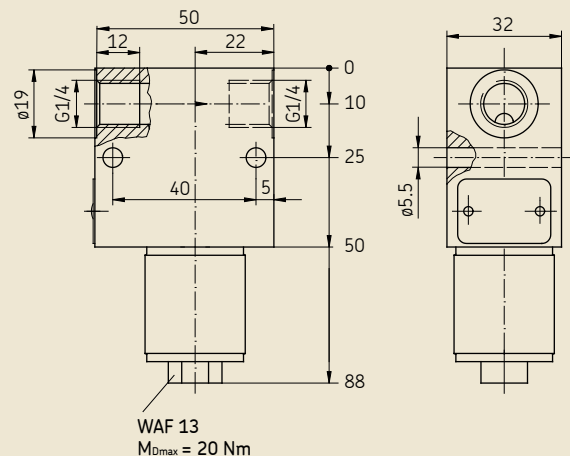

Disk filters

General

In the main and by-pass flow, disk filters can be used. Wire disk filters are suitable for the filtration of very soiled media. The filter elements are flushed from the outside to the inside. The filter rating is determined by the gap width.

Disk filters are easy to maintain and are characterized by their long service life.

Cleaning can be performed during operation by turning the handle. The dirt particles collect in the collecting area and are emptied by loosening the screw plug during operation or downtimes.

CAUTION

Strictly adhere to the installation height shown in the technical drawings to enable the change of the filter element.

Table 7

Disk filters Order No	Dim. draw.	Gap width	Nominal flow [l/min]	Operating pressure [bar]	Operating overpressure [bar]	Max. differential pressure strength coil [bar]	Connections
169-420-011	25	30 µm	35 ¹⁾	40	–	–	G 1
169-420-016	27	130 µm	60	–	40/63	40	G 1
169-420-017	26	30 µm	18	40	–	–	G 3/4
169-420-018	27	100 µm	40	40	–	40	G 1

¹⁾ The flow specifications apply to fluids with a viscosity of 72 mm²/s at a flow resistance of 0.2 to 0.4 bar. In case the amount of dirt is low and the flow resistance may increase, the indicated flow specifications can be exceeded.



Accessories

Connecting pieces, see brochure **1-0103-EN**.

Return filters

Filter installation

The return filter is installed on a container or tank and prevents dirt particles in fluid from entering the system.

Thereby are especially the pump units protected.

Filter design

- The return filter consists of:
- Housing
- Element
- Container ventilation

Optionally, an electric dirt indicator, a pressure switch and/or a by-pass valve can be included with the filter (see table 8).

Filter element

The filter element removes the solids from the lubricant.

- Filter element in star crimp
- Large filter areas
- Low pressure losses
- Especially long maintenance intervals
- Flow direction from the outside to the inside

Filter maintenance

The dirt indicator displays when the next filter maintenance is due. Proper maintenance helps to maximize utilization of filter elements.

Table 8

Return filters Order No	Dim. draw.	Filter rating [µm]	Filter area [cm ²]	Filter element [bar]	Nominal flow [l/min]	Operating pressure max. [bar]	Valve setting [bar]	Connection	Pressure switch [bar] (set)
248-501.62	28	100	80	169-400-022	25	–	–	G 1/2	–
248-501.72	28	60	220	–	40	–	1.5	G 1/2	–
248-501.92	28	440	80	–	25	–	–	G 1/2	–
169-450-004	29	60	900	169-400-104	95	10	1.5	G 1	–
169-450-006	28	75	–	169-400-015	18	15	–	G 1/2	–
169-450-009	30	10	–	–	18	16	2.5	G 1/2	1.2 ±0.2

¹⁾ max. switching capacity = 100 VAAC/DC; max. switching capacity = 42 VAC/DC; switching type = NO-contact

Technical datat

Characteristics

Fluid temperature range –30 °C to +100 °C
 Mounting position preferably vertically, discharge is pointing down

Min. diff. pressure 0.5 to 1 bar
 Connections G 1/2; G1

Nominal flow from 18 to 95 liters
 Volumetric flows up to 40 liters
 63 liters

Compatibility with fluids Mineral oils, environmentally-friendly hydraulic fluids

Materials

Cover Polyamide, GF-reinforced
 Housing Aluminum
 Gasket FKM (NBR)
 Filter Microfiber fleece, Paper, Filter fabric



Accessories

Connecting pieces, see brochure 1-0103-EN.

CAUTION

Strictly adhere to the installation height shown in the technical drawings to enable the change of the filter element.

Return filters

Fig. 28

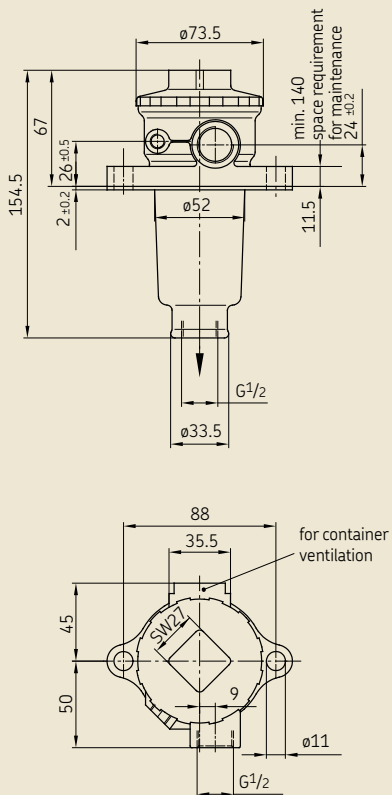

Fig. 29

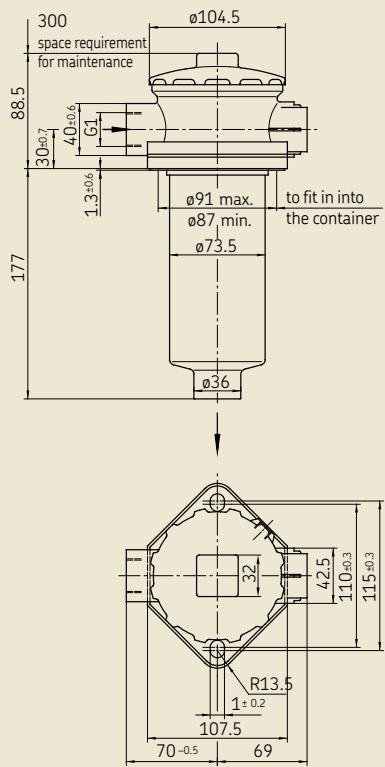
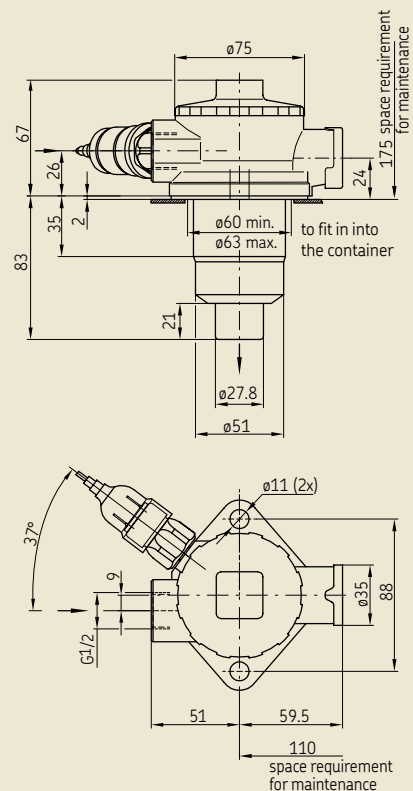

Fig. 30



Venting filters

Table 9

Venting filters Order No.	Dim. draw.	Filter rating [μm]	Filter element	Temperature range [$^{\circ}\text{C}$]
169-400-079	31	10	Paper fleece	-30 to +100
169-400-081	32	10	Papiervlies	-30 to +100
169-400-086	33	3	Papiervlies	-30 to +100
169-400-112	34	10	Papiervlies	-30 to +100
169-400-337	35	40	Polyurethane foam	-15 to +100

Fig. 31

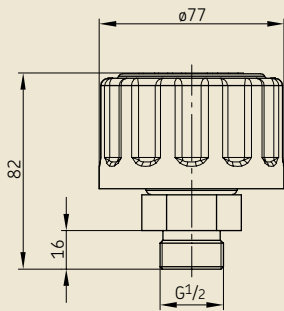

Fig. 33

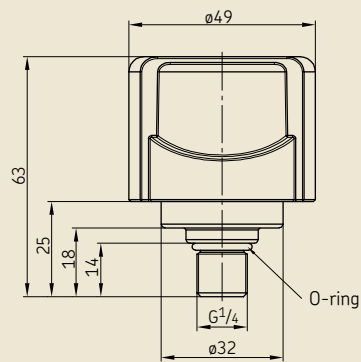

Fig. 35

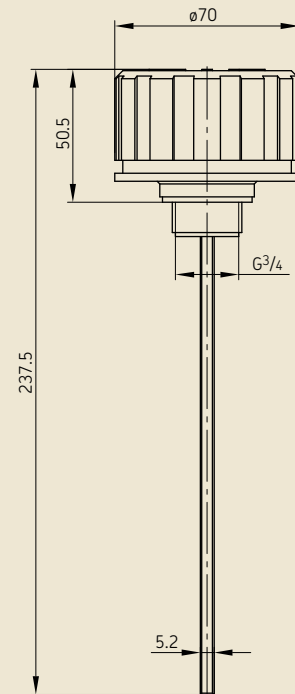

Fig. 32

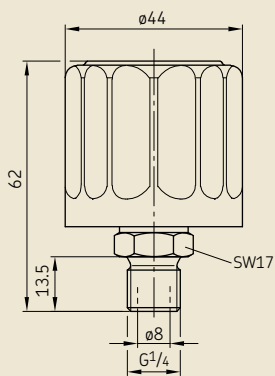
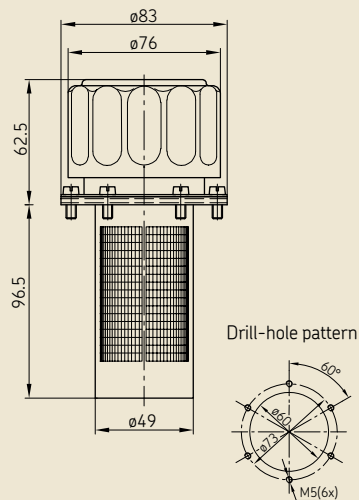

Fig. 34



**Important information on product usage**

SKF and Lincoln lubrication systems or their components are not approved for use with gases, liquefied gases, pressurized gases in solution and fluids with a vapor pressure exceeding normal atmospheric pressure (1.013 mbar) by more than 0,5 bar at their maximum permissible temperature.

Additional brochures for further information:

1-0103-DE *Fittings and Accessories*

1-9201-DE *Transport of Lubricants in Centralized Lubrication Systems*

SKF Lubrication Systems Germany GmbH

Berlin Plant
Motzener Str. 35/37 · 12277 Berlin
PO Box 970444 · 12704 Berlin
Germany

Tel. +49 (0)30 72002-0
Fax +49 (0)30 72002-111

This brochure was presented to you by:

© SKF is a registered trademark of the SKF Group.

© SKF Group 2018

The contents of this publication are the copyright of the publisher and may not be reproduced (even extracts) unless prior written permission is granted. Every care has been taken to ensure the accuracy of the information contained in this publication, but no liability can be accepted for any loss or damage whether direct, indirect or consequential, arising out of use of the information contained herein.

1-0116-EN • October 2018

