



Year-end report 2016

Press release 2 February

In 2016 we have seen market conditions gradually improve and SKF is now growing again. In the fourth quarter, organic sales increased by 1.2% compared to last year. Sequentially, sales were slightly higher, mainly driven by Asia. Net sales in the quarter were SEK 18.8 billion. We saw a gradual strengthening in demand during the quarter and less of the seasonal pre-buying which is otherwise associated with that time of year.

Operating profit, excluding one-time items, was SEK 1 741 million, which was slightly higher than last year. Our operating margin, excluding one-time items, was 9.3%. The cost in the quarter for our new ERP-system amounted to SEK 280 million and impacted the margin negatively by 1.5 percentage points.

Our industrial business delivered an operating margin, excluding one-time items, of 11.0%. We saw higher demand in Asia, especially in industrial distribution, but also in industrial drives. Total demand in Europe was relatively unchanged but we saw growth in our distribution business as well as in the rail and industrial general industries. In North America, market conditions continue to be challenging, but the development in the market is stabilizing.

Our automotive business delivered an operating margin, excluding one-time items, of 5.3%. Organic sales increased by 3.3% in the quarter, compared to the corresponding quarter

last year, driven mainly by strong growth in Asia for both cars and trucks.

Our cash flow continued to be strong, at SEK 1 428 million in the fourth quarter. Net debt decreased by SEK 3 billion and strengthened the balance sheet and brought us close to our net debt/equity target of 80%.

In the past month, we have announced further strategic investments in our factories in Schweinfurt, Germany and Dalian, China. During the last 18 months, investments have been announced in our manufacturing facilities and distribution centres across the world. The first of the investments to be completed is the new spherical roller bearing channel in Gothenburg, where the first customer trial orders are now being produced.

Our new ERP-system went live in Sweden and Finland on 4 January. This is a significant investment for the Group and I am pleased to say that the launch went according to plan.

For the first quarter 2017, demand for our products and services is expected to be slightly higher compared to last year and relatively unchanged compared to the fourth quarter of 2016.

Alrik Danielson
President and CEO

Key figures

Key figures	Q4 2016	Q4 2015	2016	2015
Net sales, SEKm	18 785	18 215	72 787	75 997
Operating profit excl. one-time items, SEKm	1 741	1 726	7 544	8 655
Operating margin excl. one-time items, %	9.3	9.5	10.4	11.4
One-time items in operating profit, SEKm	-155	-687	-17	-1 687
Operating profit, SEKm	1 586	1 039	7 527	6 968
Operating margin, %	8.4	5.7	10.3	9.2
Financial one-time items, SEKm	-	-286	-	-336
Profit before taxes excl. operating and financial one-time items, SEKm	1 531	1 626	6 756	7 857
Profit before taxes, SEKm	1 376	653	6 739	5 834
Net cash flow after investments before financing, SEKm	1 428	1 966	7 717	6 416

Net sales change y-o-y, %:	Organic	Structure	Currency	Total
Q4 2016	1.2	-1.8	3.7	3.1
Full year	-1.6	-2.2	-0.4	-4.2

Organic sales change in local currencies, per region y-o-y, %:	Europe	North America	Latin America	Asia	Middle East & Africa
Q4 2016	0.9	-4.4	-4.5	8.1	6.6
Full year	1.7	-7.3	-4.1	-0.9	2.3

Dividend proposal

The Board has decided to propose an unchanged dividend of SEK 5.50 per share to the Annual General Meeting.

Outlook for the first quarter 2017

Demand compared to the first quarter 2016

The demand for SKF's products and services is expected to be slightly higher for the Group and for Industrial. Demand for Automotive is expected to be higher. Demand is expected to be slightly higher in Europe, North America and in Latin America and higher in Asia.

Demand compared to the fourth quarter 2016

The demand for SKF's products and services is expected to be relatively unchanged for the Group and for Industrial. Demand for Automotive is expected to be higher. Demand is expected to be higher in Europe and North America, slightly lower in Latin America and significantly lower in Asia.

Previous outlook statement

Demand compared to the fourth quarter 2015

The demand for SKF's products and services is expected to be relatively unchanged for the Group and for Industrial. Demand for Automotive is expected to be slightly higher. Demand is expected to be relatively unchanged in Europe, lower in North America, slightly higher in Asia and higher in Latin America.

Demand compared to the third quarter 2016

The demand for SKF's products and services is expected to be relatively unchanged for the Group including both Industrial and Automotive. Demand is expected to be slightly higher in Europe, lower in North America and relatively unchanged in Asia and in Latin America.

Sales

Segment information	Q4				Full year 2016			
	Organic	Structure	Currency	Total	Organic	Structure	Currency	Total
Net sales, change y-o-y, %:								
Industrial	0.3	-2.5	3.7	1.5	-2.8	-3.1	-0.3	-6.2
Automotive	3.3	0.0	3.7	7.0	1.2	0.0	-0.5	0.7

Segment information	Q4					Full year 2016				
	Europe	North America	Latin America	Asia	Middle East & Africa	Europe	North America	Latin America	Asia	Middle East & Africa
Organic sales in local currencies, change y-o-y:										
Industrial	+/-	--	--	++	+/-	+/-	---	---	--	+++
Automotive	+/-	--	---	+++	+	++	---	+/-	+++	--

Customer industries	Q4					Full year 2016				
	Europe	North America	Latin America	Asia	Middle East & Africa	Europe	North America	Latin America	Asia	Middle East & Africa
Organic sales in local currencies, change y-o-y:										
Industrial distribution	+	-	---	+++	++	+/-	--	---	+/-	+/-
Industrial, general	+	+++		+++		+/-	+++	---	+/-	--
Industrial, heavy, special and off-highway	---	+++	--	+/-	--	--	+++	---	---	--
Energy	+/-	+++	---	---		---	---	+++	---	
Aerospace	---	---		---		-	+/-		+++	
Railway	++	---		--		+	--		---	
Cars and light trucks	+	---	---	+++		++	---	---	+++	
Vehicle aftermarket	+/-	++	+	---	+++	++	++	--	---	-
Trucks	++	---		+++		++	--	+++	+++	
Two-wheelers and electrical	--			---		-	+++		---	
Other industry	+++	---		-	+++	+++	---	+++	+	+++

Comments on organic sales in local currencies in Q4 2016, compared to Q4 2015

Europe

Industrial: Overall, sales were relatively unchanged in the quarter. By industry, sales to the railway industry was higher and sales to industrial distribution and industrial general industries were slightly higher. Sales to the energy industry was relatively unchanged while sales to the aerospace industry and to the heavy, special and off-highway industries were significantly lower.

Automotive: Sales in the quarter were relatively unchanged compared to last year with higher sales to the truck industry, slightly higher sales to the cars and light trucks industry and relatively unchanged sales to the vehicle aftermarket.

North America

Industrial: Sales were lower in the quarter compared to Q4 2015. By industry, sales to the energy industry and to industrial, heavy, special and off-highway industries as well as to industrial general industries were all significantly higher. Sales to industrial distribution was slightly lower and sales to railway, aerospace and other industries were significantly lower compared to Q4 last year.

Automotive: Sales in the quarter were lower, including significantly lower sales to the truck industry and the cars and light trucks industry and higher sales to the vehicle aftermarket.

Asia

Industrial: Sales were higher in the quarter. By industry, sales to industrial distribution and industrial general industries were significantly higher, sales to industrial, heavy, special and off-highway industries were relatively unchanged while sales to the aerospace and to the energy industries were significantly lower compared to Q4 2015.

Automotive: Sales were significantly higher compared to Q4 2015. Sales were significantly higher to the truck industry and to the cars and light trucks industries, and significantly lower to the vehicle aftermarket.

Latin America

Industrial: Overall, sales were lower in the quarter. By industry, sales to the heavy, special and off-highway industries were lower while sales all other industries were significantly lower.

Automotive: Sales were significantly lower in the quarter. Sales to the vehicle aftermarket were slightly higher while sales to the car and light trucks industry were significantly lower compared to Q4 2015.

Financial performance

Fourth quarter 2016

- Operating profit for the fourth quarter was 1 586 million (1 039). Operating profit was positively impacted by lower one-time items, increased sales and manufacturing volumes, savings from cost reduction programmes and currency effects compared to the fourth quarter 2015. Operating profit was also negatively impacted by sales price development, customer mix, higher cost for the ERP implementation, general inflation and divested companies. Operating profit included one-time items of -155 million (-687) whereof -117 million related to restructuring and cost reduction activities primarily in Americas and Europe and the remainder related to impairments. Of the -155 million in one-time items in the fourth quarter -66 million (-452) were included in cost of goods sold, -91 million (-208) in selling and administrative expenses and +2 million (-27) in other operating income and expenses.

Operating profit bridge, SEKm	Q4
2015	1 039
One-time items at 2015 exchange rates	533
Operational performance *	-76
Currency impact	130
Divested/acquired companies, ie net divestment	-40
2016	1 586

* Operational performance includes the effects on operating profit related to changes in: organic sales, manufacturing volumes, manufacturing cost and changes in selling and administrative expenses.

- Financial income and expense, net in the fourth quarter was -210 million (-386). Exchange rate fluctuations had limited impact in the fourth quarter 2016 while it had a positive impact in 2015. Additionally the fourth quarter in 2015 included one-time items of -286 million related to buy-back of bonds.
- Taxes in the fourth quarter was -406 million (-225) resulting in an effective tax rate of 29.5% (34.5%).
- Cash flow after investments before financing in the fourth quarter was 1 428 million (1 966). Excluding acquisitions and divestments it was 1 528 million (2 048). Net cash flow used for financing activities in the fourth quarter in 2015 was negatively impacted by costs related to the buy-back of bonds of -369 million.
- Net working capital in percent of annual sales was 29.9% in the fourth quarter compared to 27.1% in the fourth quarter 2015. The ratio was negatively impacted by exchange rates developments in the fourth quarter by around +2.5%.
- Provisions for post-employment benefits net, decreased by -1 511 million (decrease -951) in the fourth quarter, mainly as a result of increases in discount rates in Germany, the USA, UK and Sweden.

Full year 2016

- Operating profit for the year was 7 527 million (6 968). Operating profit was positively impacted by lower one-time items, savings from cost reduction programmes and lower material prices compared to 2015. Operating profit was also negatively impacted by lower sales and manufacturing volumes, sales price development, customer mix, higher costs for the ERP implementation, general inflation and divested companies. Operating profit 2016 included one-time items of -17 million (-1 687) whereof -576 million (-1 199) related to the restructuring and cost reduction program, -191 million net (-431) related to profit on sold businesses, impairments, and write-off of assets, +618 million (0) related to a curtailment gain due to changed conditions in the defined benefit retirement plans and 0 million (-57) million related to negative revaluation effects due to currency developments. Of the -17 million in one-time items 2016, +30 million (-958) were included in cost of goods sold, -49 million (-751) in selling and administrative expenses and +2 million (+22) in other operating income and expenses.

Operating profit bridge, SEKm	2016
2015	6 968
One-time items at 2015 exchange rates	1 669
Operational performance *	-789
Currency impact	-200
Divested/acquired companies, ie net divestment	-121
2016	7 527

* Operational performance includes the effects on operating profit related to changes in: organic sales, manufacturing volumes, manufacturing cost and changes in selling and administrative expenses.

- The financial net amounted to -788 million in 2016 (-1 134). 2015 included one-time items amounting to -336 million including the -276 million related to the buyback of bonds, -140 million related to negative revaluation effects due to currency developments in Latin America, and the remaining +80 million to the gain on the sale of equity securities.
- Taxes in 2016 was -2 530 million (-1 760) giving an effective tax rate of 37.5% (30.2%). Taxes were negatively impacted by divestments of businesses by -386 million. Excluding this, the effective tax rate for the year was 31.8%. Adjusted for tax benefits not recognised as tax assets, the effective tax rate for the year was 30.4%.
- Cash flow after investments before financing was 7 717 million (6 416) and excluding acquisitions and divestments it was 5 014 million (5 670). Other financial items in financing activities included a payment of 526 million, net of taxes, related to our contribution to the defined benefit retirement plan. Net cash flow used for financing activities in 2015 was impacted by -935 million related to derivatives on external financing activities.
- For the full year 2016, the provision for post-employment benefits increased net by +882 million (-932). The increase net comprised of an increase related to discount rate decreases in Germany, the USA, UK and Sweden and a decrease related to the curtailment gain and the one-time payment related to the defined benefit retirement plans.

Key figures

	31 Dec 2016	31 Sept 2016	31 Dec 2015
Net working capital, % of annual sales	29.9	30.3	27.1
ROCE for the 12-month period, %	11.9	11.1	10.9
Net debt/equity, %	84.4	104.7	99.9
Net debt/EBITDA	2.4	2.7	2.7

Segment information*

SEKm unless otherwise stated

Industrial	Q4/2016	Q4/2015	2016	2015
Net sales	13 108	12 909	50 756	54 132
Operating profit	1 322	900	6 103	6 229
Operating margin, %	10.1	7.0	12.0	11.5
One-time items	-121	-542	-9	-1 242
Operating profit excl. one-time items	1 443	1 442	6 112	7 471
Operating margin excl. one-time items, %	11.0	11.2	12.0	13.8

Automotive	Q4/2016	Q4/2015	2016	2015
Net sales	5 668	5 299	22 005	21 842
Operating profit	264	139	1 424	739
Operating margin, %	4.7	2.6	6.5	3.4
One-time items	-34	-145	-8	-445
Operating profit excl. one-time items	298	284	1 432	1 184
Operating margin excl. one-time items, %	5.3	5.4	6.5	5.4

* Previously published figures have been restated. See page 8.

Guidance Q1 2017

- Financial net: -225 million
- Based on exchange rates as of December 31 2016, the currency impact on the operating profit compared to Q1 2016 is expected to be around 200 million.

Guidance 2017

- Tax level: around 30%
- Additions to property, plant and equipment: around 2 200 million.

Net sales for Industrial 2016

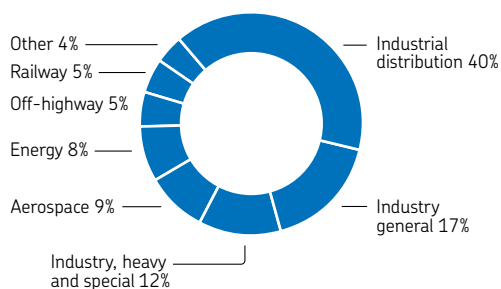

Net sales for Automotive 2016

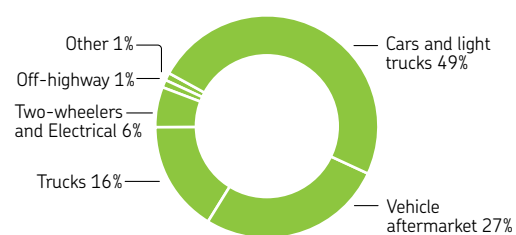

Highlights

Modernizing distribution centres

SKF is investing SEK 225 million in upgrading its distribution centres across Europe and India. The investments will improve customer lead-times and service levels, whilst contributing to reduced stock levels throughout SKF's logistics chain.

Investing in manufacturing in China and Germany

SKF is investing SEK 70 million in developing roller manufacturing capabilities in Dalian, China and a total of SEK 295 million in modernizing its cylindrical roller bearing (CRB) manufacturing and large-size bearing (LSB) production in Schweinfurt, Germany.

New global software center

SKF is gathering its expertise in condition monitoring by creating a global development center for software in Europe, located in Gothenburg and Luleå, Sweden, as well as Aberdeen and Livingston, Scotland. The largest unit is placed in Gothenburg, which is responsible for software development of next generation technology from SKF.

Raids against retailers of counterfeit bearings

SKF participated in three simultaneous raids against retailers of counterfeit bearings in China. The raids, which were led by Chinese police, resulted in the seizure of counterfeit bearings which may otherwise have been sold to industrial customers and end-users.

New business

Magnetic bearings to Cryostar

SKF secured a contract with Cryostar, a French manufacturer of turbo-expanders, to supply SKF S2M magnetic bearings and the latest generation E300V2 control cabinet.

SKF delivers hub bearings to the new Cadillac CT6

SKF is supplying General Motors with front and rear wheel hub bearing units for the new 2016 Cadillac CT6 prestige luxury sedan. The new hub bearing units are developed in partnership with GM and are stiffer, smoother, quieter and longer lasting.

New Products

SKF highlights latest sealing solutions

At EICMA 2016, SKF unveiled the latest version of its shock absorber sealing system for off-road vehicles such as enduro and cross motorcycles, snowmobiles and quads.

Shaft alignment tool

SKF announced the introduction of its SKF Shaft Alignment Tool TKSA 71. Designed for professional alignment in harsh industrial environments, it provides superior alignment performance and long service life.

Electric cartridge pump

SKF announced the introduction of the Electric Cartridge Pump (ECP). Developed to lubricate bearings and linear guides in small machines, this reliable pump includes an integrated pressure-relief valve that enables its use in single-line lubrication systems such as SKF MonoFlex.

SKF hub bearing unit seal

SKF introduced a newly developed inboard seal for hub bearing units that leads to a 50 percent cut in friction when compared with other competing seals. Specifically designed for the application, the innovative technology combines outstanding sealing capabilities over a long service life in even the most challenging environments with the power to boost overall vehicle efficiency and a substantial drop in CO₂ emissions.

New SKF grease

SKF launched a new grease that has been proven to reduce the risk of damage, caused by wear and corrosion, in hub bearing units. The risk of damage is reduced by more than 50 percent when compared with competing greases.

SKF Roller Profile Rail Guide LLU

SKF launched a new series of linear guides with rollers recirculation for the global market. The range meets the need of OEMs that require high stiffness and load carrying capacity in a compact design. Load capacity is up to doubled compared to traditional profile rail guides with balls. Ideal for a wide range of industries, including: machine tools, heavy machinery and plastic injection molding.



Cylindrical roller bearing



SKF S2M magnetic bearing



SKF Shaft Alignment Tool TKSA 71

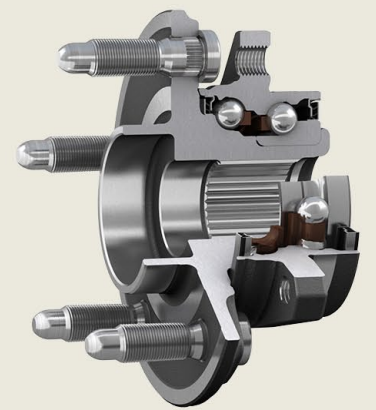

Hub bearing unit for Cadillac CT6



SKF Distribution centre

Accounting principles

The consolidated financial statements of the SKF Group were prepared in accordance with International Financial Reporting Standards (IFRS) as adopted by the EU. The SKF Group applied the same accounting principles and methods of computation in the interim financial statements as compared with the

latest annual report. No amended IFRS effective 2016 had a material impact on the SKF Group's financial statements.

The financial statements of the Parent company were prepared in accordance with the "Annual Accounts Act" and the RFR 2 "Accounting for legal entities".

Segment information

As previously announced, SKF changed its segment reporting from the second quarter 2016. The Group's segment information is specified per industrial and automotive customer and not based on the operational organisation.

Industrial and Automotive include sales and operating profit to all significant industrial and automotive customers respectively as well as assets/liabilities, net, related to these sales. Previously published figures have been restated accordingly. See investors.skf.com

SKF's Performance Share Programme

In order to continue to link the interests of the participants and the shareholders long-term, the Board proposes, that a decision be taken at the Annual General Meeting 2017 on SKF's Performance Share Programme 2017. The terms and conditions for SKF's Performance Share Programme 2017 are the same as for SKF's Performance Share Programme 2016.

It is proposed that the programme covers a maximum of 225 senior managers and key employees in the SKF Group, including Group Management, with the opportunity of being allotted, free of charge, SKF B shares.

The number of shares that may be allotted must be related to the degree of achievement of the Total Value Added (TVA) target level, as defined by the Board, for the TVA development for the

financial years 2017–2019 compared to the financial year 2016. Under the programme, not more than 1,000,000 SKF B shares may be allotted.

SKF's Performance Share Programme 2014, which was decided by the Annual General Meeting 2014 will be settled in the first quarter 2017. The outcome is that about 200 managers of the SKF Group will receive around 33,800 SKF class B shares (around 3% of the maximum number of shares approved by the Annual General Meeting), based on the degree of achievement of TVA target level for the financial year 2014, and the TVA development for the financial year 2016 compared to the financial year of 2014. The total cost for the SKF's Performance Share Programme 2014 amounted to around SEK 6 million including social charges.

Risks and uncertainties in the business

The SKF Group operates in many different industrial, automotive and geographical areas that are at different stages of the economic cycle. A general economic downturn at global level, or in one of the world's leading economies, could reduce the demand for the Group's products, solutions and services for a period of time. In addition, terrorism and other hostilities, as well as disturbances in worldwide financial markets and natural disasters, could have a negative effect on the demand for the Group's products and services. There are also political and Regulatory risks associated with the wide geographical presence.

Regulatory requirements, taxes, tariffs and other trade barriers, price or exchange controls or other governmental policies could limit the SKF Group's operations. The SKF Group is subject to both transaction and translation of currency exposure. For commercial flows the SKF Group is primarily exposed to the EUR, USD and to USD-related currencies. As the major part of the profit is made outside Sweden, the Group is also exposed to translational risks in all the major currencies. The financial position of the parent company is dependent on the financial position and development of the subsidiaries. A general decline in the demand for the products and services provided by the Group could mean lower residual profits and lower dividend

income for the parent company, as well as a need for writing down values of the shares in the subsidiaries.

SKF and other companies in the bearing industry are part of investigations by the US Department of Justice and the Korea Fair Trade Commission regarding a possible violation of anti-trust rules. SKF is subject to two investigations in Brazil by the General Superintendence of the Administrative Council for Economic Defense, one investigation regarding an alleged violation of antitrust rules concerning bearing manufacturers, and another investigation regarding an alleged violation of antitrust rules by several companies active on the automotive aftermarket in Brazil. An enquiry has been initiated by the Competition Commission of India against several different companies, including SKF, regarding an alleged violation of antitrust rules in India. Moreover, SKF is subject to related class action claims by direct and indirect purchasers of bearings in the United States and may face additional follow-on civil actions by both direct and indirect purchasers. Each of Peugeot S.A. and BMW AG, and several of their respective group companies, have separately initiated lawsuits, with claims for damages, against bearing manufacturers, including SKF, that were part of the settlement decision by the European Commission for violation of European competition rules.

Gothenburg, 2 February 2017
Aktiebolaget SKF (publ)

Alrik Danielson
President and CEO

Condensed consolidated income statements

SEKm	Oct-Dec 2016	Oct-Dec 2015	Jan-Dec 2016	Jan-Dec 2015
Net sales	18 785	18 215	72 787	75 997
Cost of goods sold	-14 383	-14 214	-54 984	-57 483
Gross profit	4 402	4 001	17 803	18 514
Selling and administrative expenses	-2 841	-2 874	-10 268	-11 603
Other operating income/expenses, net	25	-88	-8	57
Operating profit	1 586	1 039	7 527	6 968
Operating margin, %	8.4	5.7	10.3	9.2
Financial income and expense, net	-210	-386	-788	-1 134
Profit before taxes	1 376	653	6 739	5 834
Taxes	-406	-225	-2 530	-1 760
Net profit	970	428	4 209	4 074
Net profit attributable to:				
Shareholders of the parent	889	374	3 985	3 880
Non-controlling interests	81	54	224	194

Condensed consolidated statements of comprehensive income

SEKm	Oct-Dec 2016	Oct-Dec 2015	Jan-Dec 2016	Jan-Dec 2015
Net profit	970	428	4 209	4 074
Items that will not be reclassified to the income statement:				
Remeasurements	1 577	784	-1 746	1 236
Income taxes	-509	-229	423	-334
	1 068	555	-1 323	902
Items that may be reclassified to the income statement:				
Exchange differences arising on translation of foreign operations	413	-574	1 273	-445
Available-for-sale assets	-20	223	-205	217
Cash-flow hedges	4	-1	18	41
Income taxes	-9	-31	50	-361
	388	-383	1 136	-548
Other comprehensive income, net of tax	1 456	172	-187	354
Total comprehensive income	2 426	600	4 022	4 428
Shareholders of AB SKF	2 303	557	3 714	4 221
Non-controlling interests	123	43	308	207

Condensed consolidated balance sheets

SEKm	December 2016	December 2015
Goodwill	11 137	12 078
Other intangible assets	8 431	9 407
Property, plant and equipment	15 746	15 303
Deferred tax assets	3 806	3 185
Other non-current assets	1 688	1 607
Non-current assets	40 808	41 580
Inventories	15 418	14 519
Trade receivables	13 462	11 777
Other current assets	3 133	3 357
Other current financial assets	11 086	8 500
Current assets	43 099	38 153
Total assets	83 907	79 733
Equity attributable to shareholders of AB SKF	26 034	24 815
Equity attributable to non-controlling interests	1 649	1 467
Long-term financial liabilities	22 031	22 383
Provisions for post-employment benefits	13 945	13 062
Provisions for deferred taxes	1 380	1 373
Other long-term liabilities and provisions	1 490	1 302
Non-current liabilities	38 846	38 120
Trade payables	7 100	5 671
Short-term financial liabilities	1 619	1 442
Other short-term liabilities and provisions	8 659	8 218
Current liabilities	17 378	15 331
Total equity and liabilities	83 907	79 733

Condensed consolidated statements of changes in shareholders' equity

SEKm	Jan-Dec 2016	Jan-Dec 2015
Opening balance 1 January	26 282	24 404
Total comprehensive income	4 022	4 428
Cost for performance share programmes, net	14	14
Other, including transactions with non-controlling interests	–	41
Total cash dividends	-2 635	-2 605
Closing balance	27 683	26 282

Condensed consolidated statements of cash flow

SEKm	Oct-Dec 2016	Oct-Dec 2015	Jan-Dec 2016	Jan-Dec 2015
Operating activities:				
Operating profit	1 586	1 039	7 527	6 968
Depreciation, amortization and impairment	623	959	2 368	2 858
Net loss/gain (-) on sales of PPE and businesses	-15	-4	-8	-217
Taxes	-479	-460	-1 897	-2 320
Other including non-cash items	19	-347	-815	-918
Changes in working capital	445	1 501	-25	1 360
Net cash flow from operations	2 179	2 688	7 150	7 731
Investing activities:				
Payments for intangible assets, PPE, businesses and equity securities	-1 076	-651	-2 654	-2 423
Sales of PPE, businesses and equity securities	325	-71	3 221	1 108
Net cash flow used in investing activities	-751	-722	567	-1 315
Net cash flow after investments before financing	1 428	1 966	7 717	6 416
Financing activities:				
Change in short- and long-term loans	-18	-7	-1 990	-942
Other financial items	82	-371	-510	-1 304
Cash dividends	-39	-38	-2 635	-2 605
Investments in short-term financial assets	-298	-161	-653	-560
Sales of short-term financial assets	111	-27	570	212
Net cash flow used in financing activities	-162	-604	-5 218	-5 199
Net cash flow	1 266	1 362	2 499	1 217
Change in cash and cash equivalents:				
Cash and cash equivalents at 1 Oct / 1 January	8 599	5 928	7 218	5 920
Cash effect excl. acquired/sold businesses	1 264	1 362	2 579	1 199
Cash effect of acquired/sold businesses	2	-	-80	18
Exchange rate effect	74	-72	222	81
Cash and cash equivalents at 31 December	9 939	7 218	9 939	7 218

Change in net debt	Closing balance 31 Dec 2016	Other non cash changes	Businesses acquired/sold	Cash changes	Translation effect	Opening balance 1 January 2016
Loans, long- and short-term	20 399	158	-	-1 990	882	21 349
Post-employment benefits, net	13 892	1 102	-25	-888	693	13 010
Financial assets, others	-995	1	-	-75	-49	-872
Cash and cash equivalents	-9 939	-	80	-2 579	-222	-7 218
Net debt	23 357	1 261	55	-5 532	1 304	26 269

Number of shares

	Oct-Dec 2016	Oct-Dec 2015	Jan-Dec 2016	Jan-Dec 2015
Total number of shares:	455 351 068	455 351 068	455 351 068	455 351 068
- whereof A shares	36 298 533	36 298 533	36 298 533	36 298 533
- whereof B shares	419 052 535	419 052 535	419 052 535	419 052 535
Weighted average number of shares in:				
- basic earnings per share	455 351 068	455 351 068	455 351 068	455 351 068
- diluted earnings per share	455 631 417	455 351 068	455 631 417	455 351 068

Condensed consolidated financial information

Amounts in SEKm unless otherwise stated

	Q1/15	Q2/15	Q3/15	Q4/15	Q1/16	Q2/16	Q3/16	Q4/16
Net sales	19 454	19 961	18 367	18 215	17 720	18 370	17 912	18 785
Cost of goods sold	-14 652	-14 768	-13 849	-14 214	-13 305	-13 880	-13 416	-14 383
Gross profit	4 802	5 193	4 518	4 001	4 415	4 490	4 496	4 402
Gross margin, %	24.7	26.0	24.6	22.0	24.9	24.4	25.1	23.4
Selling and administrative expenses	-3 121	-2 910	-2 698	-2 874	-2 516	-2 594	-2 317	-2 841
- as % of sales	16.0	14.6	14.7	15.8	14.2	14.1	12.9	15.1
Other, net	40	100	5	-88	-24	-21	12	25
Operating profit	1 721	2 383	1 825	1 039	1 875	1 875	2 191	1 586
Operating margin, %	8.8	11.9	9.9	5.7	10.6	10.2	12.2	8.4
One-time items in operating profit	-655	-194	-151	-687	-97	-145	380	-155
Operating profit excl. one-time items	2 376	2 577	1 976	1 726	1 972	2 020	1 811	1 741
Operating margin excl. one-time items, %	12.2	12.9	10.8	9.5	11.1	11.0	10.1	9.3
Financial net	-129	-142	-477	-386	-217	-219	-142	-210
Financial one-times	80	-	-130	-286	-	-	-	-
Profit before taxes	1 592	2 241	1 348	653	1 658	1 656	2 049	1 376
Profit margin before taxes, %	8.2	11.2	7.3	3.6	9.4	9.0	11.4	7.3
Profit before taxes excl. total one-time items	2 167	2 435	1 629	1 626	1 755	1 801	1 669	1 531
Profit margin before taxes excl. total one-time items, %	11.1	12.2	8.9	8.9	9.9	9.8	9.3	8.2
Taxes	-427	-535	-573	-225	-514	-950	-660	-406
Net profit	1 165	1 706	775	428	1 144	706	1 389	970
Net profit attributable to								
Shareholders of the parent company	1 120	1 662	724	374	1 091	654	1 351	889
Non-controlling interests	45	44	51	54	53	52	38	81

Reconciliation to profit before tax for the Group

SEKm	Q1/15	Q2/15	Q3/15	Q4/15	Q1/16	Q2/16	Q3/16	Q4/16
Operating profit:								
Industrial*	1 653	2 096	1 580	900	1 534	1 514	1 733	1 322
Automotive*	68	287	245	139	341	361	458	264
Financial net	-129	-142	-477	-386	-217	-219	-142	-210
Profit before taxes for the Group	1 592	2 241	1 348	653	1 658	1 656	2 049	1 376

* Previously published figures have been restated. See page 8.

Key figures

(Definitions, see page 15)

	Q1/15	Q2/15	Q3/15	Q4/15	Q1/16	Q2/16	Q3/16	Q4/16
EBITA, SEKm	1 860	2 522	1 963	1 177	2 008	2 007	2 299	1 702
EBITDA, SEKm	2 323	3 104	2 400	1 999	2 453	2 459	2 774	2 209
Basic earnings per share, SEK	2.46	3.65	1.59	0.82	2.40	1.44	2.97	1.95
Diluted earnings per share, SEK	2.46	3.65	1.59	0.82	2.40	1.44	2.96	1.95
Dividend per share, SEK	–	5.50	–	–	–	5.50	–	–
Net worth per share, SEK	54	54	53	54	54	49	52	57
Share price at the end of the period, SEK	222.8	189.1	153.7	137.2	146.6	134.1	148.1	167.6
NWC, % of annual sales	32.1	30.9	29.7	27.1	28.2	30.0	30.3	29.9
ROCE for the 12-month period, %	12.6	12.6	11.9	10.9	11.2	10.6	11.1	11.9
ROE for the 12-month period, %	19.9	21.2	17.9	15.7	15.5	11.8	14.4	16.5
Gearing, %	59.7	56.8	58.3	56.7	58.0	61.1	58.6	55.3
Equity/assets ratio, %	29.9	32.2	31.8	33.0	32.2	29.5	31.1	33.0
Additions to property, plant and equipment, SEKm	433	576	557	497	376	410	452	632
Net debt/equity, %	122.2	113.4	114.2	99.9	105.7	117.7	104.7	84.4
Net debt, SEKm	31 739	29 514	29 390	26 269	27 471	27 915	26 500	23 356
Registered number of employees	48 356	47 579	47 051	46 635	45 926	45 043	45 128	44 868

SKF has applied the new guidelines issued by ESMA (European Securities and Markets Authority) on APMs (Alternative Performance Measures). These key figures are not defined or specified in IFRS but provides complementary information to investors and other stakeholders on the

company's performance. The definition of each APM is presented at the end of the interim report. For the reconciliation of each APM against the most reconcilable line item in the financial statements, see skf.com/group/investors/.

Segment information – quarterly and yearly figures*

Amounts in SEKm unless otherwise stated

Industrial	Q1/15	Q2/15	Q3/15	Q4/15	Q1/16	Q2/16	Q3/16	Q4/16
Net sales	13 919	14 240	13 064	12 909	12 375	12 922	12 351	13 108
Operating profit	1 653	2 096	1 580	900	1 534	1 514	1 733	1 322
Operating margin, %	11.9	14.7	12.1	7.0	12.4	11.7	14.0	10.1
One-time items	-501	-109	-90	-542	-54	-122	288	-121
Operating profit excl. one-time items	2 154	2 205	1 670	1 442	1 588	1 636	1 445	1 443
Operating margin excl. one-time items, %	15.5	15.5	12.8	11.2	12.8	12.7	11.7	11.0
Assets and liabilities, net	45 822	43 471	42 624	40 987	40 782	38 160	38 046	39 352
Registered number of employees	38 930	38 286	37 989	37 659	36 904	36 382	36 483	36 306

Automotive	Q1/15	Q2/15	Q3/15	Q4/15	Q1/16	Q2/16	Q3/16	Q4/16
Net sales	5 529	5 717	5 297	5 299	5 337	5 444	5 556	5 668
Operating profit	68	287	245	139	341	361	458	264
Operating margin, %	1.2	5.0	4.6	2.6	6.4	6.6	8.2	4.7
One-time items	-154	-85	-61	-145	-43	-23	92	-34
Operating profit excl. one-time items	222	372	306	284	384	384	366	298
Operating margin excl. one-time items, %	4.0	6.5	5.8	5.4	7.2	7.1	6.6	5.3
Assets and liabilities, net	9 909	9 927	9 486	8 977	9 253	9 644	9 685	9 337
Registered number of employees	7 751	7 669	7 567	7 506	7 385	7 163	7 150	7 060

* Previously published figures have been restated. See page 8.

Parent company condensed income statements

SEKm	Oct-Dec 2016	Oct-Dec 2015	Jan-Dec 2016	Jan-Dec 2015
Revenue	1 613	1 235	5 061	6 006
Cost of revenue	-955	-1 379	-4 598	-5 317
General management and administrative expenses	-820	-582	-1 448	-1 699
Other operating income/expenses, net	-1	-1	-1	-5
Operating loss	-163	-727	-986	-1 015
Financial income and expense, net	-294	-422	3 814	2 707
Profit before taxes	-457	-1 149	2 828	1 692
Appropriations	2 140	1 125	2 140	1 125
Taxes	-886	453	-667	587
Net profit	797	429	4 301	3 404

Parent company condensed statements of comprehensive income

SEKm	Oct-Dec 2016	Oct-Dec 2015	Jan-Dec 2016	Jan-Dec 2015
Net profit	797	429	4 301	3 404
Items that may be reclassified to the income statement:				
Available-for-sale-assets	-20	221	-206	215
Other comprehensive income, net of tax	-20	221	-206	215
Total comprehensive income	777	650	4 095	3 619

Parent company condensed balance sheets

SEKm	December 2016	December 2015
Intangible assets	1 939	1 757
Investments in subsidiaries	22 403	21 317
Receivables from subsidiaries	18 567	19 637
Other non-current assets	755	1 457
Non-current assets	43 664	44 168
Receivables from subsidiaries	4 683	3 589
Other receivables	131	119
Current assets	4 814	3 708
Total assets	48 478	47 876
Shareholders' equity	18 432	16 827
Untaxed reserves	69	179
Provisions	544	379
Non-current liabilities	19 166	19 761
Current liabilities	10 267	10 730
Total shareholders' equity, provisions and liabilities	48 478	47 876

Definitions

Average number of employees

Total number of working hours of registered employees, divided by the normal total working time for the period.

Basic earnings/loss per share in SEK

Profit/loss after taxes less non-controlling interests divided by the ordinary number of shares.

Currency impact on operating profit

The effects of both translation and transaction flows based on current assumptions and exchange rates and compared to the corresponding period last year.

Debt

Loans and net provisions for post-employment benefits.

Diluted earnings per share

Diluted earnings per share is calculated using the weighted average number of shares outstanding during the period adjusted for all potential dilutive ordinary shares.

EBITA (Earnings before interest, taxes and amortization)

Operating profit before amortizations.

EBITDA (Earnings before interest, taxes, depreciation and amortization)

Operating profit before depreciations, amortizations, and impairments.

Equity/assets ratio

Equity as a percentage of total assets.

Gearing

Debt as a percentage of the sum of debt and equity.

Net debt

Debt less short-term financial assets excluding derivatives.

Net debt/EBITDA

Net debt, as a percentage of twelve months rolling EBITDA.

Net debt/equity

Net debt, as a percentage of equity.

Net worth per share (Equity per share)

Equity excluding non-controlling interests divided by the ordinary number of shares.

NWC (Net working capital)

Trade receivables plus inventory minus trade payables as a percentage of twelve months rolling net sales.

One-time items

Significant income/expense of a non recurring and non business related nature. This includes, but is not limited to, restructuring costs, impairments and write-offs, currency exchange rate effects caused by devaluations and gains and losses on divestments of businesses and assets.

Operating margin

Operating profit/loss, as a percentage of net sales.

Operating margin excl. one-time items

Operating profit/loss excluding one-time items, as a percentage of net sales.

Operational performance

Operational performance includes the effects on operating profit related to changes in organic sales, changes in manufacturing volumes and manufacturing cost and changes in selling and administrative expenses.

Organic sales

Sales excluding effects of currency and structure, i.e. acquired and divested businesses.

Registered number of employees

Total number of employees included in SKF's payroll at the end of the period.

ROCE (Return on capital employed)

Operating profit/loss plus interest income, as a percentage of twelve months rolling average of total assets less the average of non-interest bearing liabilities.

ROE (Return on equity)

Profit/loss after taxes as a percentage of twelve months rolling average of equity.

SKF demand outlook

The demand outlook for SKF's products and services represents management's best estimate based on current information about the future demand from our customers. The demand outlook is the expected volume development in the markets where our customers operate.

Cautionary statement

This report contains forward-looking statements that are based on the current expectations of the management of SKF. Although management believes that the expectations reflected in such forward-looking statements are reasonable, no assurance can be given that such expectations will prove to have been correct. Accordingly, results could differ materially from those implied in the forward-looking statements as a result of, among other factors, changes in economic, market

and competitive conditions, changes in the regulatory environment and other government actions, fluctuations in exchange rates and other factors mentioned in SKF's latest annual report (available on investors.skf.com) under the Administration Report; "Important factors influencing the financial results", "Financial risks" and "Sensitivity analysis", and in this full-year report under "Risks and uncertainties in the business."



SKF is a global supplier of bearings, seals, mechatronics, lubrication systems and services which include technical support, maintenance and reliability services, engineering consulting and training. SKF is represented in more than 130 countries and has around 17 000 distributor locations worldwide. Annual sales in 2016 were SEK 72 787 million and the number of employees was 44 868.

Further information can be obtained from

Investors and analysts

Patrik Stenberg, Head of Investor Relations
tel: +46 31 3372104
mobile: +46 705 472104
e-mail: patrik.stenberg@skf.com

Eva Österberg, Investor Relations
tel: +46 31 3373464
mobile: +46 702 253464
e-mail: eva.osterberg@skf.com

Press and media

Theo Kjellberg, Press and Media Relations Director
tel: +46 31 3376576
mobile: +46 725 776576
e-mail: theo.kjellberg@skf.com

The information in this press release is information which AB SKF is required to disclose under the EU Market Abuse Regulation (EU) No 596/2014 and pursuant to the Securities Markets Act. The information was provided by the above contact persons for publication on 2 February 2017 at 13.00 CET.

Conference call

2 February at 14.00 (CET), 13.00 (UK),
SE: +46 (0)8 5352 6408
UK: +44 (0)20 7136 2051
US: +1 718 354 1158

Please don't use a loudspeaker as this has a negative effect on the sound.

You will find all information regarding SKF's year-end results 2016 on: investors.skf.com/quarterlyreporting

Calendar

7 March, Annual Report 2016
29 March, Annual General Meeting
6 April, Capital Markets Day
27 April, First-quarter report 2017
21 July, Half-year report 2017