

K02-RD

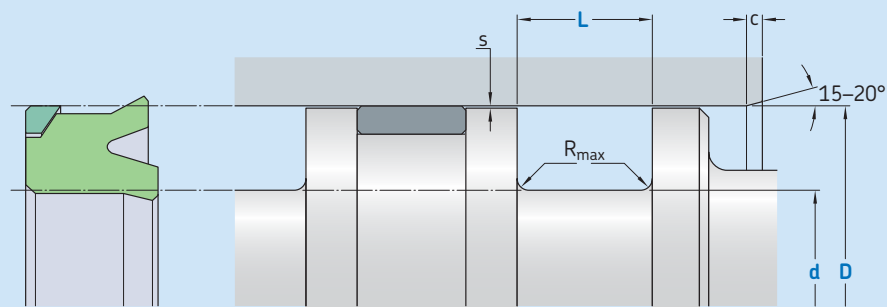

Ordering dimensions in **blue**

Surface roughness	R_{tmax}	R_a
Sliding surface	$\leq 2,5 \mu m$	$0,05-0,2 \mu m$
Bottom of groove	$\leq 6,3 \mu m$	$\leq 1,6 \mu m$
Groove face	$\leq 15 \mu m$	$\leq 3 \mu m$

Bearing area: 50–95% and a cutting depth of $0,5 R_z$, based on $C_{ref} = 0\%$

Standard dimensions						Maximal radial extrusion gap		
D	d	L	R_{max}	c	s^*	20 bar	100 bar	250 bar
H9 over	incl. h10	+ 0,2						
mm						mm		
13	25	D - 8	6,0	0,4	3,5	0,80	0,80	0,52
25	50	D - 10	7,0	0,4	4,0	1,00	1,00	0,66
50	75	D - 12	8,0	0,4	4,5	1,25	1,20	0,72
75	150	D - 15	10,0	0,4	5,0	1,50	1,40	0,78
150	300	D - 20	12,0	0,4	6,0	2,00	1,66	0,88
300	500	D - 25	18,0	0,4	8,5	2,50	1,91	1,00
500	750	D - 30	20,0	0,4	10,0	3,00	2,18	1,13
750		D - 40	26,0	0,4	13,0	3,00	2,18	1,13

* Extrusion gap values shown above are valid for a temperature of 70 °C, higher temperatures require lower values.

Ordering example

Profile
D x d x L [mm]
Sealing material / Backup ring

Piston seal K02-RD
100 x 85 x 10
SKF Ecorubber-1 / SKF Ecotal

Operating parameters

Material Seal	Back-up ring	Temperature		Speed ¹⁾ max	Pressure ²⁾ max
		from	to		
		°C		m/s	bar (MPa)
■ SKF Ecoflas	■ SKF Ecopaek	-10	+200		
■ SKF Ecorubber-H	■ SKF Ecotal ³⁾	-25	+100	0,5	250 (25)
	■ SKF Ecomid ³⁾				
	■ SKF Ecoflon 2		+150		
■ SKF Ecorubber-1	■ SKF Ecotal ³⁾	-30	+100	0,5	250 (25)
	■ SKF Ecomid ³⁾				
■ SKF Ecorubber-2	■ SKF Ecoflon 2	-20	+200		
■ SKF Ecorubber-3	■ SKF Ecotal ³⁾	-40	+100	0,5	250 (25)
	■ SKF Ecomid ³⁾				
	■ SKF Ecoflon 2	-50	+150		

IMPORTANT NOTE: The stated operating conditions represent general indications. It is recommended not to use all maximum values simultaneously.

¹⁾ Surface speed limit values are valid only in the presence of a lubrication film.

²⁾ Pressure ratings depend on the size of the extrusion gap.

³⁾ D ≤ 260 mm → SKF Ecotal, D > 260 mm → SKF Ecomid.