

SKF Roller Encoder Unit



Monitor linear displacement with the SKF Roller Encoder Unit – the optimal solution for applications requiring outer ring rotation.

The SKF solution

The SKF Roller Encoder Unit is a plug-and-play sensor bearing unit designed for applications with outer ring rotation. It incorporates a sealed, lubricated for life 6201 SKF Explorer deep groove ball bearing. The sensor bearing unit can be easily integrated into pulleys, cams, rollers or wheels to provide a compact encoder assembly. On request, SKF can supply these sensor bearings complete with customized gears, wheels or pulleys.

Features

- Bearing and sensors integrated into a single unit
- Enables monitoring of speed, direction and linear distance traveled
- Accurate at very low speed
- Can be supplied with a user-specified gear, wheel, or pulley

Benefits

- Compact, enabling various design options
- Easy integration thanks to plug-and-play unit
- Relubrication-free
- Reduced number of components
- Enhanced system reliability



Sensor technology

The SKF Roller Encoder Unit uses compact and robust sensors that produce an incremental encoder signal. The sensors are accurate down to zero r/min. An integrated active circuit (requiring an external voltage supply) in the sensor body contains two Hall effect cells that produce an output signal consisting of two square waves. These signals can be used to determine relative position, speed, acceleration and direction of movement.

The SKF Roller Encoder Unit can provide a signal resolution ranging from 32 to 80 digital pulses per revolution.

Requirements for the receiving interface

The receiving interface must be able to process the signals, which are provided via open collector circuits. A typical schematic drawing is shown in **fig. 1**.

Resistors

Pull-up resistors should be placed between the voltage supply and the conductors for the output signals to limit the output current to 20 mA. Recommended pull-up resistors for typical voltage supply values are listed in **table 1**.

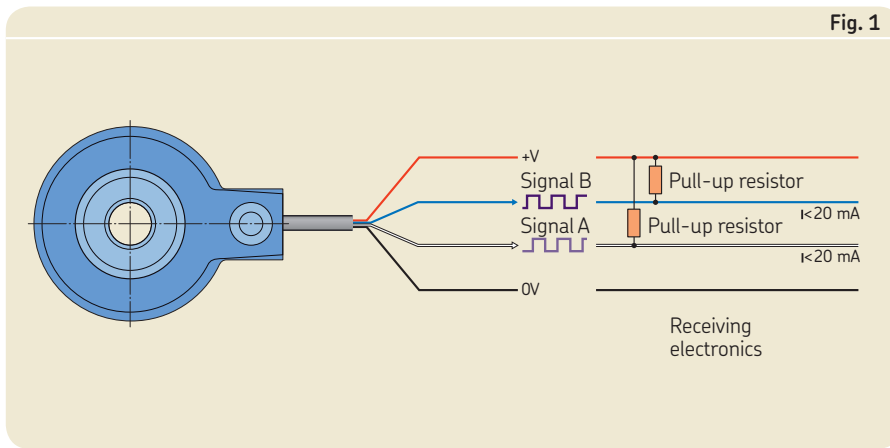

SKF Roller Encoder Unit

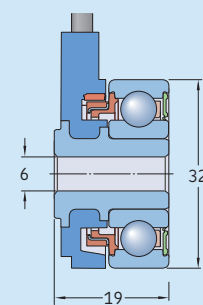

| Designation | Rotational speed | Electronic specifications | | | |
|-------------------|------------------|---------------------------|-----------------|------------|-------------|
| | | Pulses/rev | Period accuracy | Duty cycle | Phase shift |
| – | max. r/min | – | % | % | ° |
| AHE-5509 A | 5 000 | 32 | ±4 | 50±10 | 90±30 |

Table 1

Recommended pull-up resistors

| Voltage supply | Resistance min. | Power |
|----------------|-----------------|-------|
| V DC | Ω | W |
| 5 | 270 | 0,25 |
| 9 | 470 | 0,25 |
| 12 | 680 | 0,25 |
| 18 | 1 000 | 0,25 |



www.skf.com/sensorbearings

© SKF is a registered trademark of the SKF Group.

© SKF Group 2014

The contents of this publication are the copyright of the publisher and may not be reproduced (even extracts) unless prior written permission is granted. Every care has been taken to ensure the accuracy of the information contained in this publication but no liability can be accepted for any loss or damage whether direct, indirect or consequential arising out of the use of the information contained herein.

PUB BU/P8 15277 EN · November 2014

This publication supersedes publication 6289 EN.

