



Photo courtesy of Group Sidel

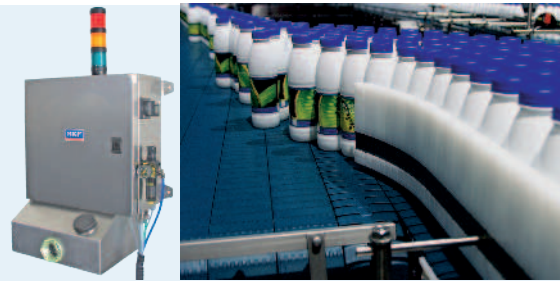

Photo courtesy of Krones Inc.

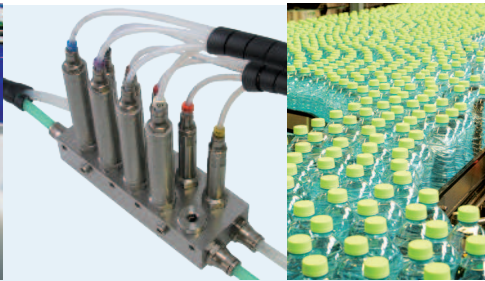

Photo courtesy of Group Sidel

SKF Dry Lubrication system for conveyors

Improve safety,
quality and efficiency
by eliminating water
and soluble lubricants

SKF Dry Lubrication system for conveyors

The SKF Dry Lubrication system, using a special lubricant, has been developed to lubricate conveyor chain surfaces, as well as chain guides, for the transport of products in bottling and packaging unit.

The aim of the SKF Dry Lubrication system is to deliver automatically and precisely the right quantity at the right friction point (chain surface or guides) from a central unit, which can feed up to 200 lubrication points in accordance with the production process.

The association of this special lubricant and the SKF Dry Lubrication system replaces the classic wet lubrication systems. This lubricant, suitable for the food and beverage industry, leaves a dry film on the chain surfaces and guides for a better sliding quality.

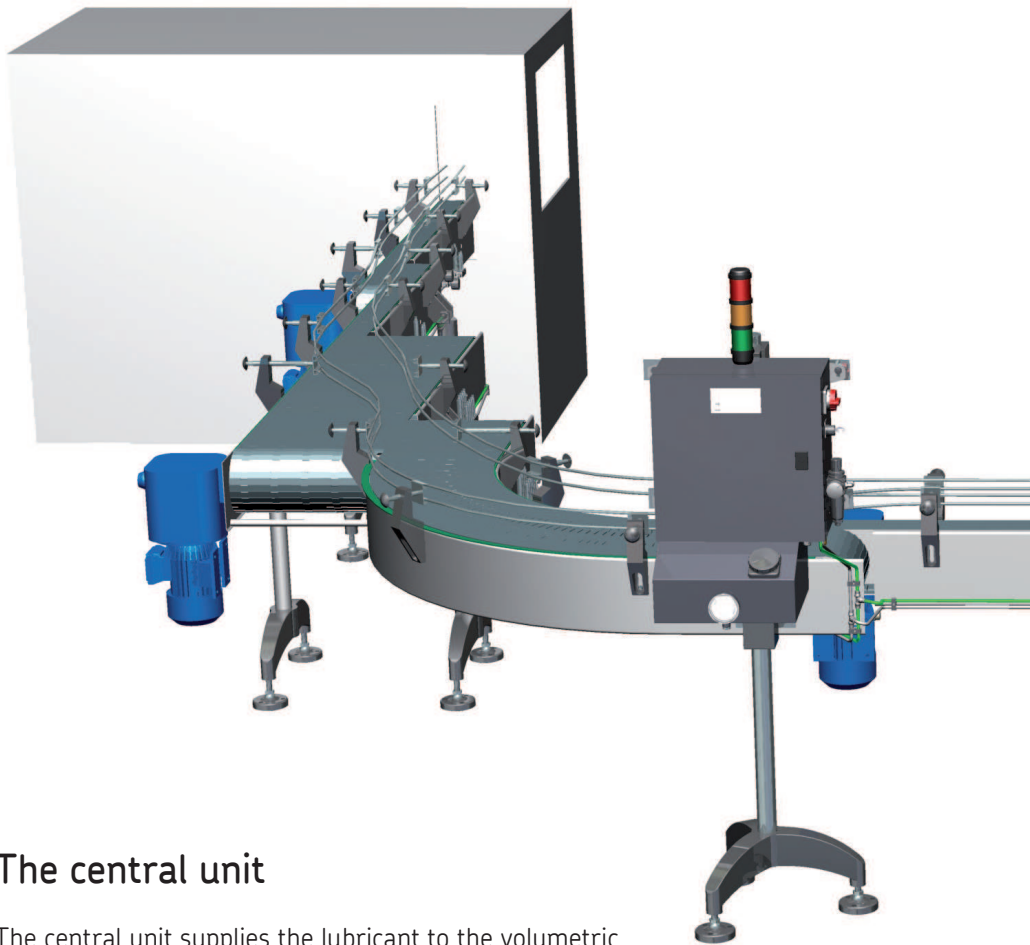

The central unit

The central unit supplies the lubricant to the volumetric distributors via the primary circuits.

It comprises the pneumatically driven pump unit and the lubricant reservoir. A control unit is integrated in the central unit. It controls and monitors the whole lubrication system.

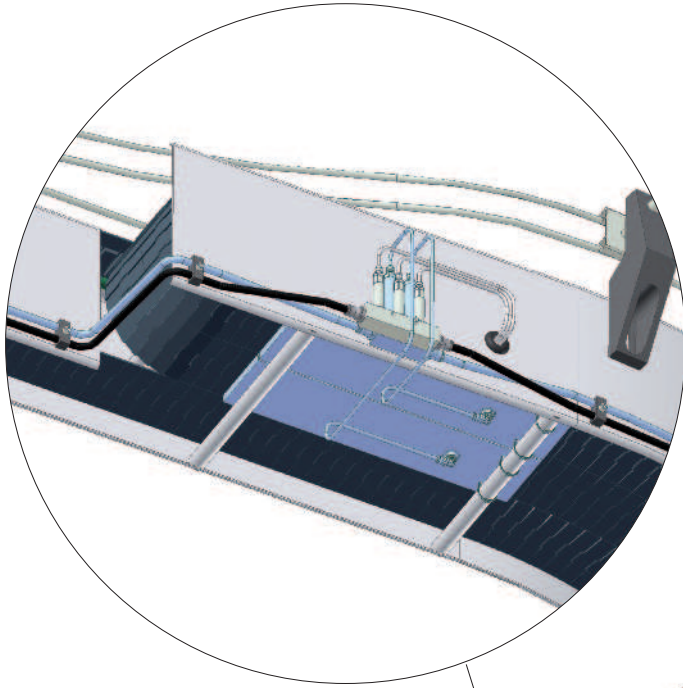

The lubrication of the chain surfaces

The piston distributors, with adjustable metered volume, feed the chain surfaces with lubricant. They deliver intermittently a metered volume of lubricant via a secondary line to lubrication plates, which are located under the chain at the end of the return strand. The chain surface sliding on the lubrication plate will be coated with lubricant.

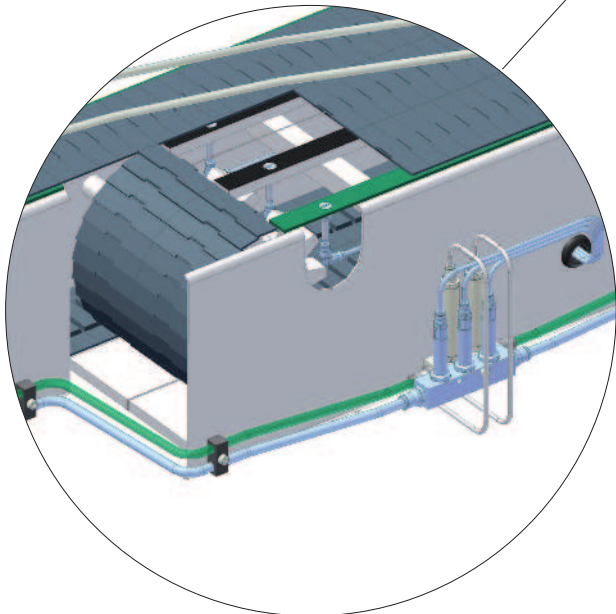
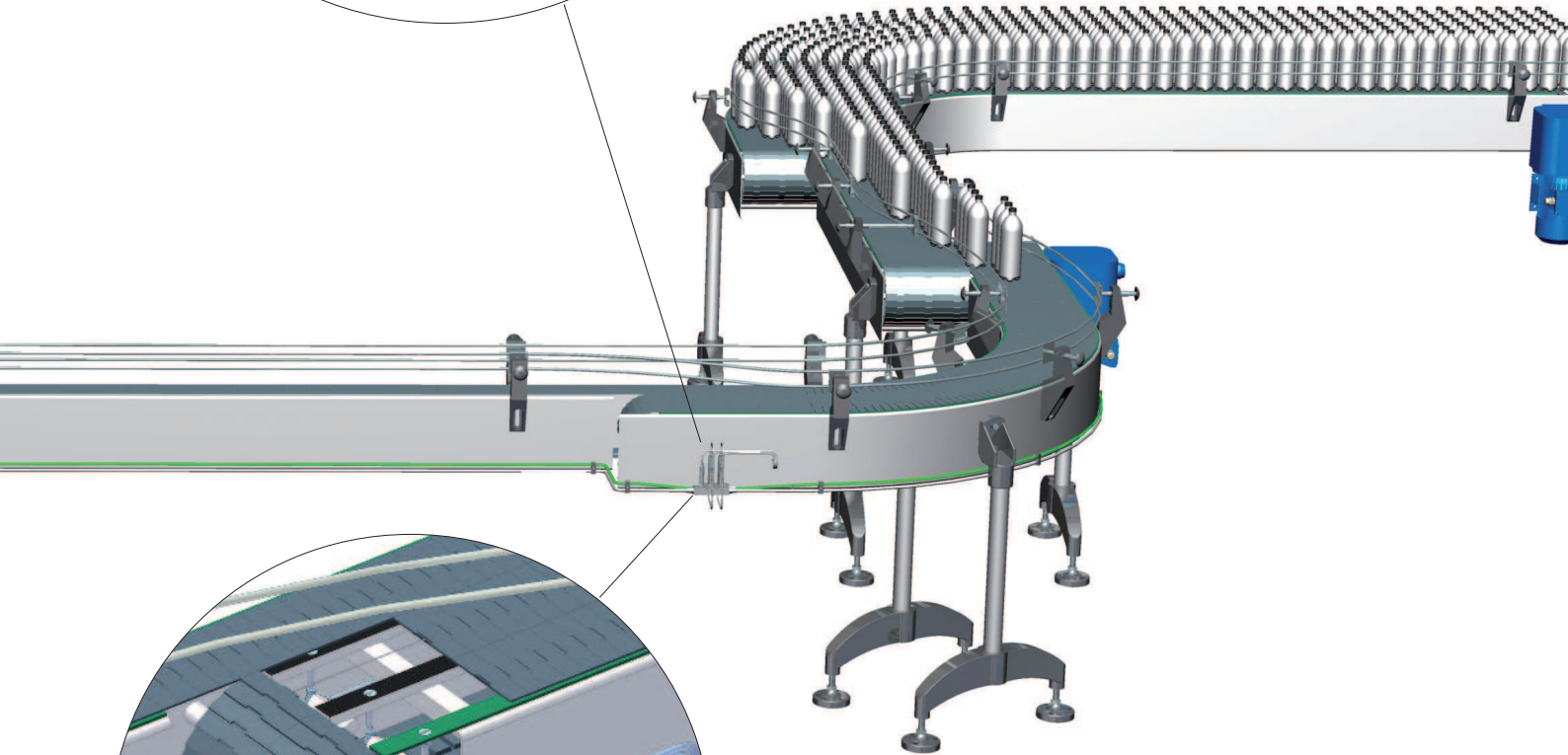

The lubrication of the chain guides

The preset piston distributors feed the chain guides with lubricant. They deliver intermittently a metered volume of lubricant via a secondary line to lubrication screws, which are inserted into the guide.

This brochure was presented by:

® SKF is a registered trademark of the SKF Group.

© SKF Group 2009

The contents of this publication are the copyright of the publisher and may not be reproduced (even extracts) unless prior written permission is granted. Every care has been taken to ensure the accuracy of the information contained in this publication but no liability can be accepted for any loss or damage whether direct, indirect or consequential arising out of the use of the information contained herein.

Order No.: 1-4123-EN (04/2009)
Subject to change without notice!

