

15.1 FSDR .. K grinding mill housings

d_a 825 – 1 460 mm

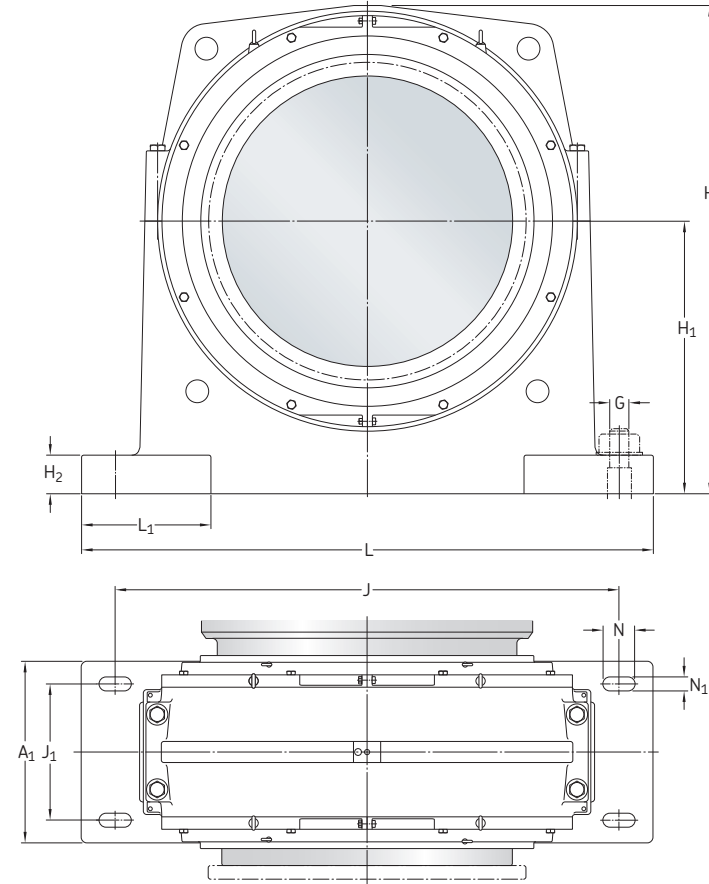
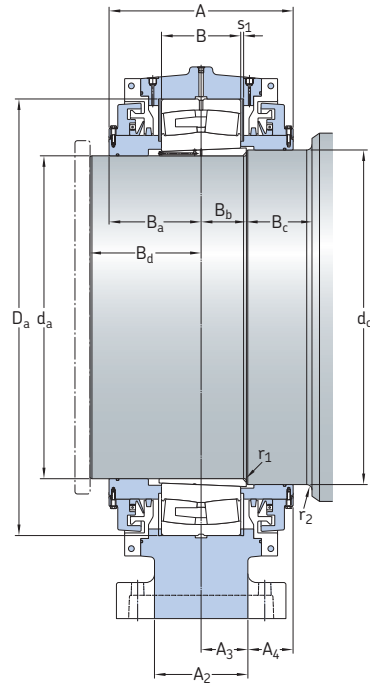

Shaft diameter d_a	Housing Designation	Appropriate parts Bearing	Unthreaded sleeve	V-ring seal	Dimensions Housing				
					A	A ₁	A ₂	A ₃	A ₄
mm	-	-			mm				
825	FSDR 39/850 K	239/850 CAK/W33	KOH 39/850	960 VRME R ¹⁾	510	450	235	117,5	137,5
1030	FSDR 39/1060 K	239/1060 CAKF/W33	KOH 39/1060	1180 VRME R ¹⁾	545	560	265	132,5	140
1150	FSDR 39/1180 K	239/1180 CAKF/W33	KOH 39/1180	1280 VRME R ¹⁾	632	560	285	142,5	173,5
1280	FSDR 49/1320 K	249/1320 CAK30F/W33	236696-1	1425 VRME R ²⁾	810	800	440	220	185
1460	FSDR 48/1500 K	248/1500 CAK30FA/W20	236558	1575 VRME R ¹⁾	585	800	360	180	112,5

¹⁾ Two seals are required for each housing.
²⁾ Four seals are required for each housing.

Shaft diameter d_a	Dimensions Housing													Dimensions Shaft abutment and fillet					Mass Housing kg		
	D _a	B	H	H ₁	H ₂	J	J ₁	L	L ₁	N	N ₁	s ₁	G	d _c	B _a ¹⁾	B _b ¹⁾	B _c	B _d ¹⁾		r ₁	r ₂
mm	mm													mm					kg		
825	1120	200	1420	700	100	1500	290	1715	430	125	55	10	48	860	255	118	252	310	10	20	2300
1030	1400	250	1700	870	120	1850	370	2105	520	132	62	10	52	1070	272,5	147	233	360	12	15	3400
1150	1540	272	1830	950	110	2000	370	2250	500	142	62	10	52	1190	316	155	245	380	12	20	3500
1280	1720	400	2150	1200	170	2220	600	2520	570	142	62	10	52	1320	405	217	283	500	12	20	6590
1460	1820	315	2225	1200	170	2320	600	2620	620	142	62	10	52	1500	292,5	173	182	355	8	25	6650

¹⁾ Dimension varies depending on the drive-up of the bearing onto the sleeve.