

# Simplex Oil Dryer

## General description

- Oil dewatering unit for aft seal lubrication oil
- Keeping the aft seal lube oil virtually free from contaminant water
- Delivered as a complete system with oil circulating pump and filter
- Available for new-builds and retrofits
- Dewatering rate up to 1,5 liters per day

## Advantages

### Design

Space-saving compact system with aft seal tank, pump, filter and control box already piped and wired on a frame

Efficient water separation by evaporation → keeping the oil quality at a high level

Active transport of vapour out of the tank through the overflow pipe

Extracts free, emulsified or dissolved water

### Installation

Plug and play solution delivered fully assembled and tested → quick and easy installation (by the shipyard)

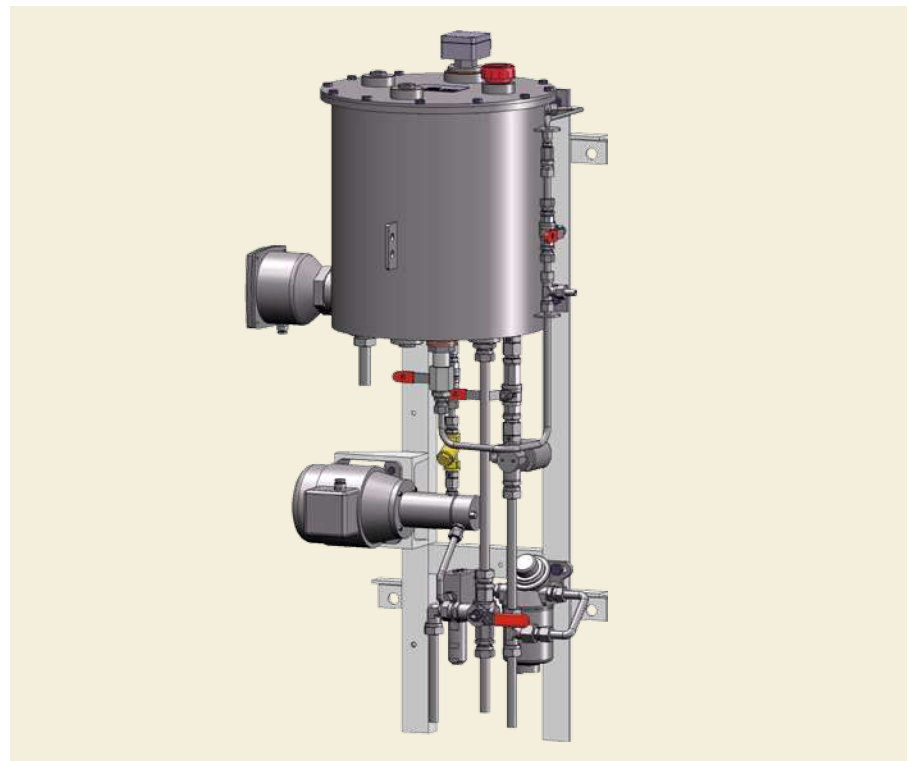

Only requirements: Seal chamber with oil inlet and outlet line (flushable), air and power supply on board

### Operation

Self-explanatory control unit → easy handling of water evaporation and oil circulation

Fail-safe system → stable oil supply to seal in case of an electrical break-down on board

### Service

Designed for in-situ overhaul as per certified and approved Simplex repair standards

Worldwide service network and availability of spares



The Original

## Function

- A pump generates continuous oil circulation between the aft seal chamber and the aft seal tank.
- The lubrication oil in the aft seal tank is moderately heated.
- The inlet air is divided into two different airflows, providing an effective removal of the water.
- One air flow is lead through the oil producing fine air bubbles that trap the water in the form of vapour.
- Once the water enters the plenum chamber above the oil, the second airflow forces the vapour to overflow through a tube towards the bilge.
- The dewatered lubrication oil is circulated back to the aft seal chamber.

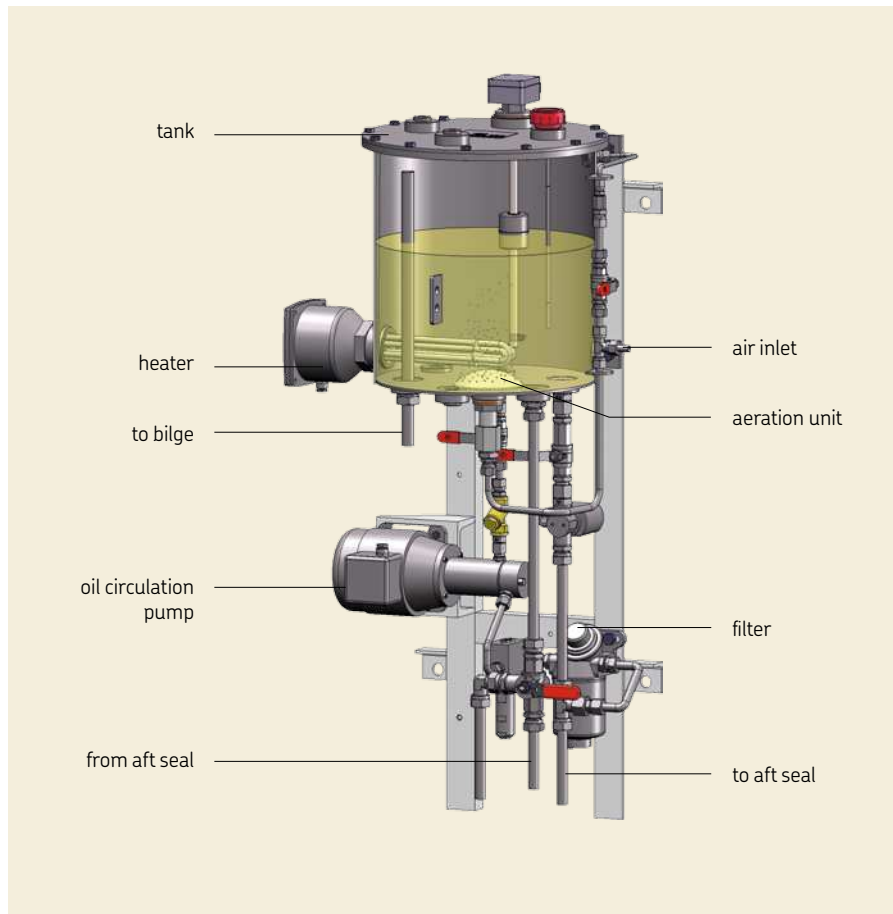

## Applications

- Especially recommended for operation with ester-based oils such as environmentally acceptable lubricants (EAL)
- Recommended as retrofit in case of increased water ingress into the stern tube aft seal

### SKF Marine GmbH

Hermann-Blohm-Straße 5  
20457 Hamburg, Germany  
sales@skf-marine.com

[skf.com](http://skf.com) | [skf-marine.com](http://skf-marine.com)

© SKF and Simplex are registered trademarks of the SKF Group.

© SKF Group 2016

The contents of this publication are the copyright of the publisher and may not be reproduced (even extracts) unless prior written permission is granted. Every care has been taken to ensure the accuracy of the information contained in this publication but no liability can be accepted for any loss or damage whether direct, indirect or consequential arising out of the use of the information contained herein.

PUB 43/P2 14951/2 EN · April 2016

Certain image(s) used under license from Shutterstock.com.