

# Compact cross table with linear motor drive

## High-precision positioning unit

### Main features:

- Drive forces up to 264N for upper axis and 603N for lower axis
- Mechanical stroke up to 308mm
- Speed up to 1,5m/s
- Acceleration up to 30m/s<sup>2</sup>
- Ironless linear motor: no attraction forces, no cogging forces
- Moving magnets for easier cabling (no moving cables to top part)
- One flat cable per axis for all connections
- Optical measurement system with integrated limit switches
- Precision cross roller rail guides with patented Anti cage Creeping System (ACS)
- Available in aluminum and cast iron
- Ideal suited for wafer processing and measurement applications



### Dynamical and electrical parameters

Stroke	mm (1)	Motor upper axis	Motor lower axis	Moving mass Al (GG25)				Fp N (2)	Fn	Ip Aeff	In	Up Vp (2)
				92	164	236	308					
				Kg (4)								
TLM300	.72			4,7 (11)	5,1 (11)	5,6 (12)	66	23	3,7	1,3	49	
	.144			5,6 (12)	5,6 (12)	6,0 (12)	133	46	5,7	2,0	63	
	.216			6,0 (12)	6,0 (12)	6,4 (13)	199	96	5,7	2,0	95	
		.072			8,3 (20)	8,3 (20)	8,7 (20)	66	23	3,7	1,3	49
		.144			8,9 (20)	8,9 (20)	9,3 (21)	133	46	5,7	2,0	63
		.216			9,4 (21)	9,4 (21)	9,8 (21)	199	96	5,7	2,0	95
TLM400	.144				10 (25)	11 (25)	11 (26)	133	46	5,7	2,0	63
	.216				11 (25)	11 (26)	12 (26)	199	69	5,7	2,0	95
	.288				11 (26)	12 (26)	12 (27)	264	92	5,7	2,0	126
		.144			15 (37)	16 (38)	16 (38)	307	65	7,6	2,6	101
		.216			16 (38)	16 (38)	17 (39)	460	97	11,4	3,9	100
		.288			17 (38)	17 (39)	17 (39)	603	124	11,5	4,0	127

**Note:**

1. The indicated value is the mechanical stroke. The electrical stroke = mechanical stroke – 2x10mm. The electrical stroke is set with optical limit switches, integrated in the length measurement system. The linear motors have reduced propulsion forces when operating between the end switches and the end stop.

2. The displayed peak force, peak current and DC link voltage values should be multiplied by 1,2 to allow sufficient amplifier headroom. The displayed voltage U (DC link voltage) is valid for a speed of 1m/s at a force Fp.

3. GG25 is cast iron, to be used when maximum running accuracy and temperature stability is required (see also table below). To get the real moving mass of the lower axis, the top axis value should be added to the lower axis value.

4. The indicated value is the mechanical stroke. The electrical. Valid for the largest possible stroke, with the upper and lower axis both in centre position.

5. Valid for 100mm stroke. For 200mm stroke Tz +1 (1) and Ty +0,5 (0,25).

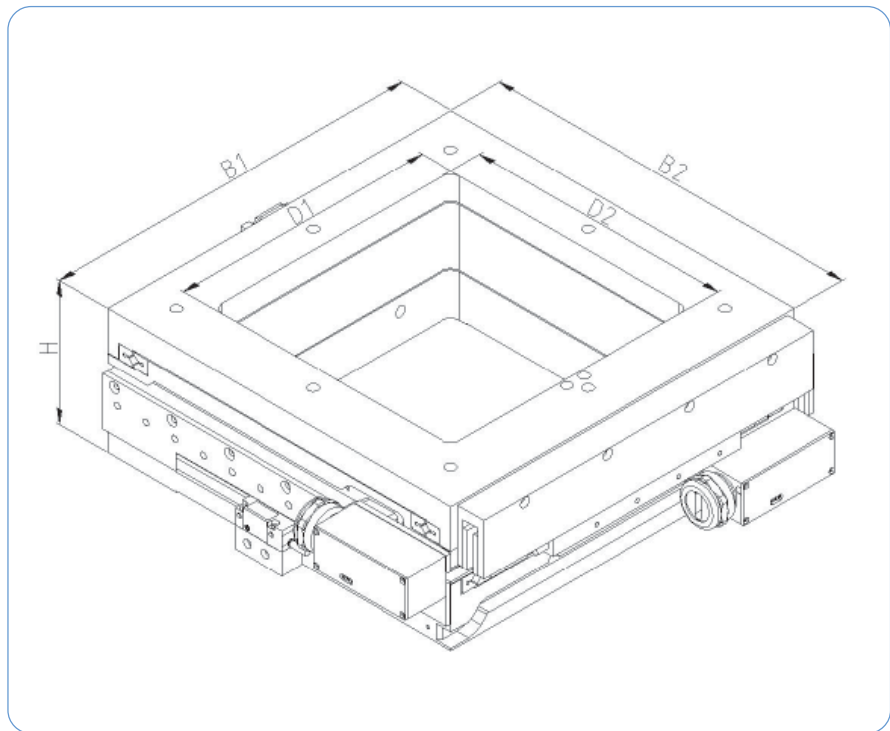

**Position feedback and limit switches**

The optical length measurement system has standard a pitch of 20µm and an output signal of 1Vpp. A TTL output signal with a resolution up to 0,1µm is available upon request. The standard accuracy class is 3µm. The integrated optical limit

switches have a galvanic isolated PNP/NC (standard) or NPN/ NC output signal. The limit switch supply voltage is 10 - 30V DC. The limit switch position, as well as the measurement system status are indicated on the system by 3 LEDs per axis.

**Mechanical parameters**

Model	Weight bottom part Al (GG25)	Stage dimensions	Min. outer dimensions	Max. outer dimensions	Through hole dimensions	Height	Height/ Side accuracy Al (GG25)	Perpendicularity
	Kg	B1 x B2 mm	(5)		D1 x D2	H	Tz / Ty µm(6)	mrad
<b>TLM300</b>	6 (16)	300 x 300	338 x 357	432 x 432	208 x 208	109	6 / 5 (5 / 4)	0,03
<b>TLM400</b>	13 (34)	400 x 401	438 x 468	576 x 576	275 x 255	145	6 / 5 (5 / 4)	0,03

