

F03

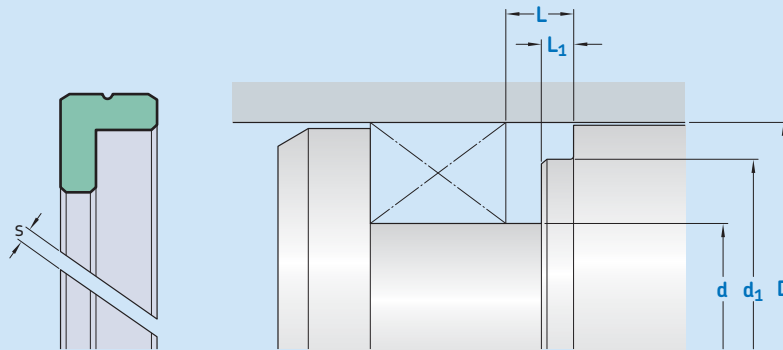

Ordering dimensions in **blue**

Sealing material Surface roughness	TPU / Elastomers		PTFE	
	R_{tmax}	R_a	R_{tmax}	R_a
	m		m	
Sliding surface	≤ 2,5	0,05–0,3	≤ 2	0,05–0,2
Bottom of groove	≤ 6,3	≤ 1,6	≤ 6,3	≤ 1,6
Groove face	≤ 15	≤ 3	≤ 15	≤ 3

Bearing area: 50–95% and a cutting depth of 0,5 R_z based on $C_{ref} = 0\%$

Standard dimensions		d_1 h10	d_1 h8	L + 0,2	L_1 + 0,2
D H9 over	incl.				
mm					
20	50	D – 10	D – 3	6,5	4
50	80	D – 15	D – 4	8	4
80	150	D – 20	D – 5	10,5	5,5
150	400	D – 25	D – 6	13,4	7
400	750	D – 30	D – 8	14,2	7
750		D – 40	D – 8	15	7

Basic version: with a cutting gap $s > 0$ allow no supporting function. For supporting function a cutting gap $s = 0$ and a spiral groove is used.
¹⁾ Cross section usually depends on the seal profile.
 Cutting gap $s \rightarrow$ values depend on material and temperature. For detailed information please refer to the profile description.

Ordering example

Profile
 $D \times d/d_1 \times L/L_1$ [mm]
 Guiding material

Guide ring F03
100 x 80/95 x 10,5/5,5
SKF Ecotal

Operating parameters

Material Guiding	Temperature		Speed ¹⁾	Specific load ²⁾
	from	to	max	
–	°C		m/s	N/mm ²
■ SKF Ecoflon 2	–200	+200	4	3,0
■ SKF Ecoflon 3			5	4,5
■ SKF Ecomid ³⁾	–40	+100	4	25
■ SKF Ecotal ³⁾	–50			

IMPORTANT NOTE: The stated operating conditions represent general indications. It is recommended not to use all maximum values simultaneously.

¹⁾ Surface speed limit values are valid only in the presence of a lubrication film.

²⁾ Depending on temperature and allowed compression. Detailed information see profile description.

³⁾ D ≤ 260 mm → SKF Ecotal, D > 260 mm → SKF Ecomid.