

Profile rail guide slides LTS with linear motor drive

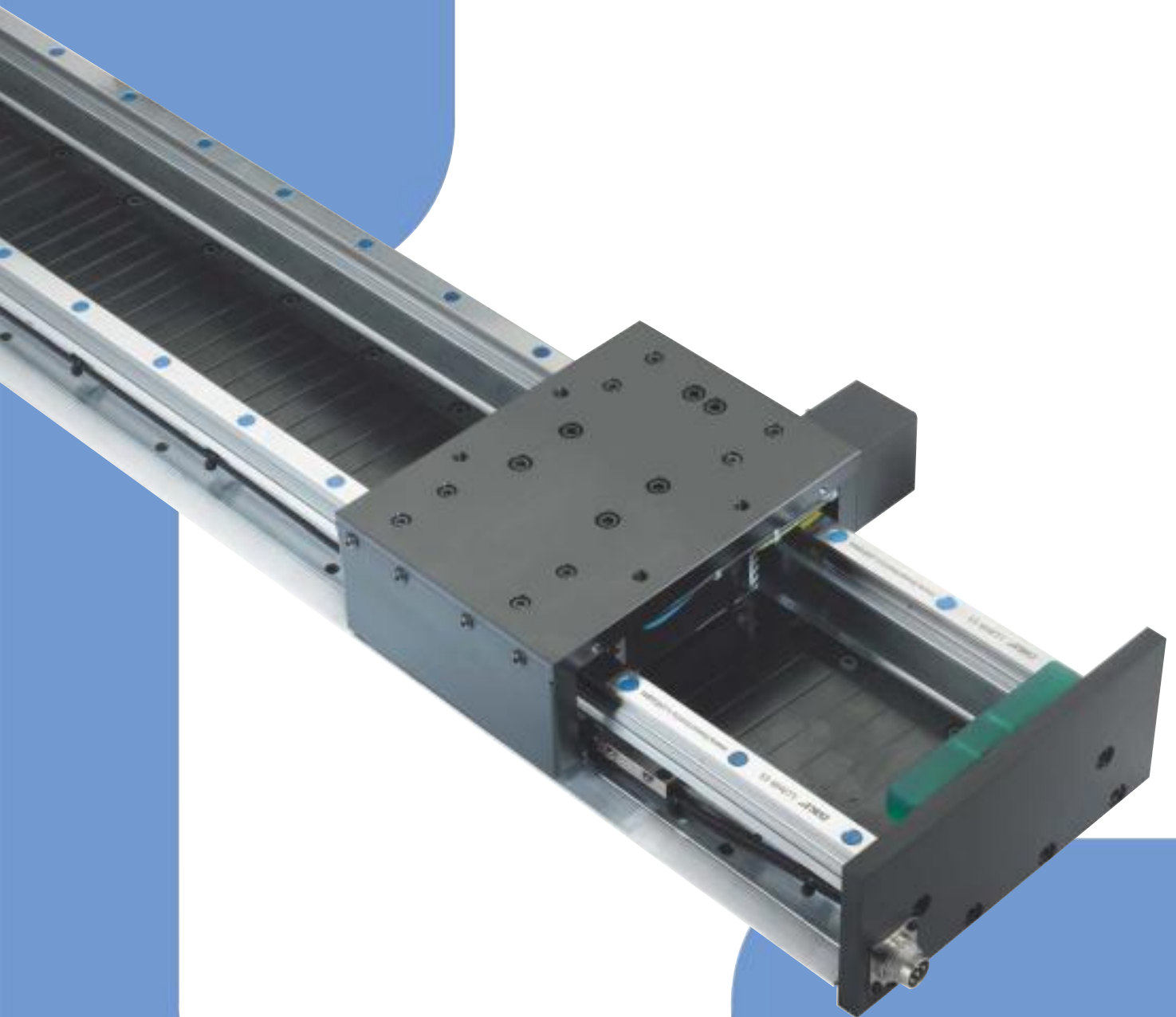

LTS profile rail guide slides are ready-to-install, complete solutions

All inclusive – the LTS functional principle

LTS profile rail guide slides consist of a stationary base which represents the intersection to the machine bed. The travelling slide top is guided by profile rails arranged in parallel.

A non-contact linear motor drives the slide top. The current-carrying primary part of the motor is located in the slide top while the segmented secondary motor part, a magnetic strip, is incorporated in the base of the profile rail guide slide.

An integrated linear measurement system is used for precise positioning. It also ensures precise speed regulation.

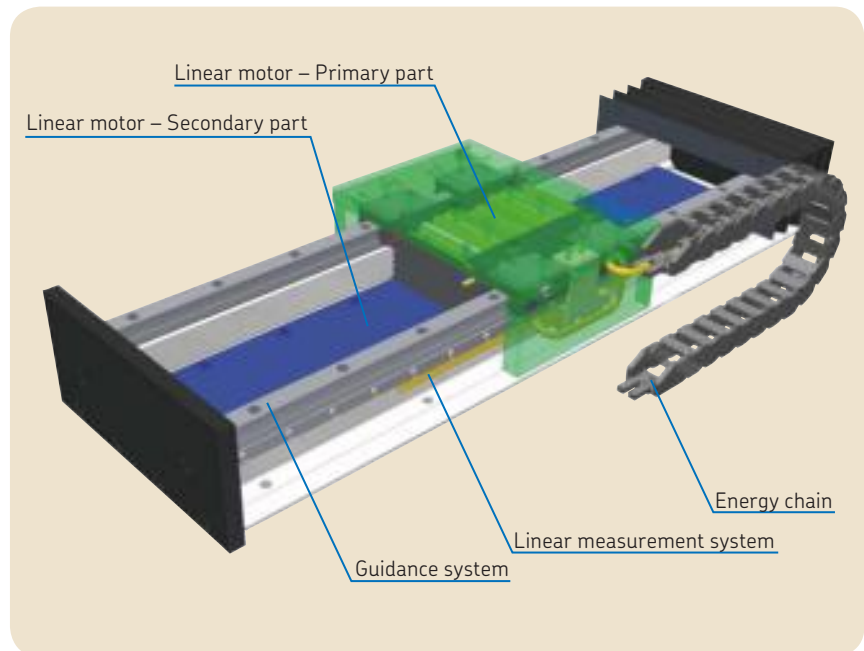

Smooth operation – Advantages of LTS slides

The use of a linear motor enables direct linear motion. Contrary to rotary load transmission, for instance with toothed belts or spindle drives, this avoids the transmission of natural frequencies or torques. Moreover, the linear motor provides non-contact and thus frictionless load transmission.

The advantages at a glance:

- Extremely precise positioning even in the nanometer range
- Highly dynamic movements even with maximum speed of travel
- Short settling time increases output
- High electrical efficiency optimises energy consumption
- Easy system integration saves implementation time

Versatile precision – LTS fields of application

LTS profile rail guide slides are designed to meet the demands for high acceleration and speeds. On the other hand, they also enable precise positioning. This makes them ideally suitable for:

- Laser machining, e.g. cutting, marking or Rapid Prototyping
- Various automation tasks
- Electronic production, e.g. pick-and-place applications, bonding, inspection

LTS technical data

Typ LTS	Max. stat. load/slide					Motor data		
	F _{0z}	F _{0y}	M _{0x}	M _{0y}	M _{0z}	F _{x,NE}	F _{MAX}	V _{MAX} ¹⁾
	kN		Nm			N		m/s
LTS 154.L1.1FN3-050-1.BL	31,8	16,2	1 524	1 143	1 143	85	320	2,6
LTS 154.L1.1FN3-050-2.BL	52,7	27,0	2 531	3 295	3 295	170	640	2,0
LTS 182.L1.1FN3-100-1.BL	31,1	16,2	1 930	1 121	1 121	170	680	2,2
LTS 182.L1.1FN3-100-2.BL	51,3	27,0	3 178	3 203	3 203	340	1 350	2,1
LTS 182.L1.1FN3-100-3.BL	77,0	40,4	4 773	7 120	7 120	510	2 030	2,1
LTS 212.L1.1FN3-150-1.BL	30,5	16,2	2 347	1 097	1 097	260	1 030	2,3
LTS 212.L1.1FN3-150-2.BL	50,2	27,0	3 864	3 136	3 136	515	2 060	2,3
LTS 212.L1.1FN3-150-3.BL	75,1	40,4	5 779	6 380	6 380	775	3 100	2,3

¹⁾ at F_{MAX}

They are fitted with Siemens 1FN3 integrated direct drives, high-precision linear guides and an integrated linear measurement system.

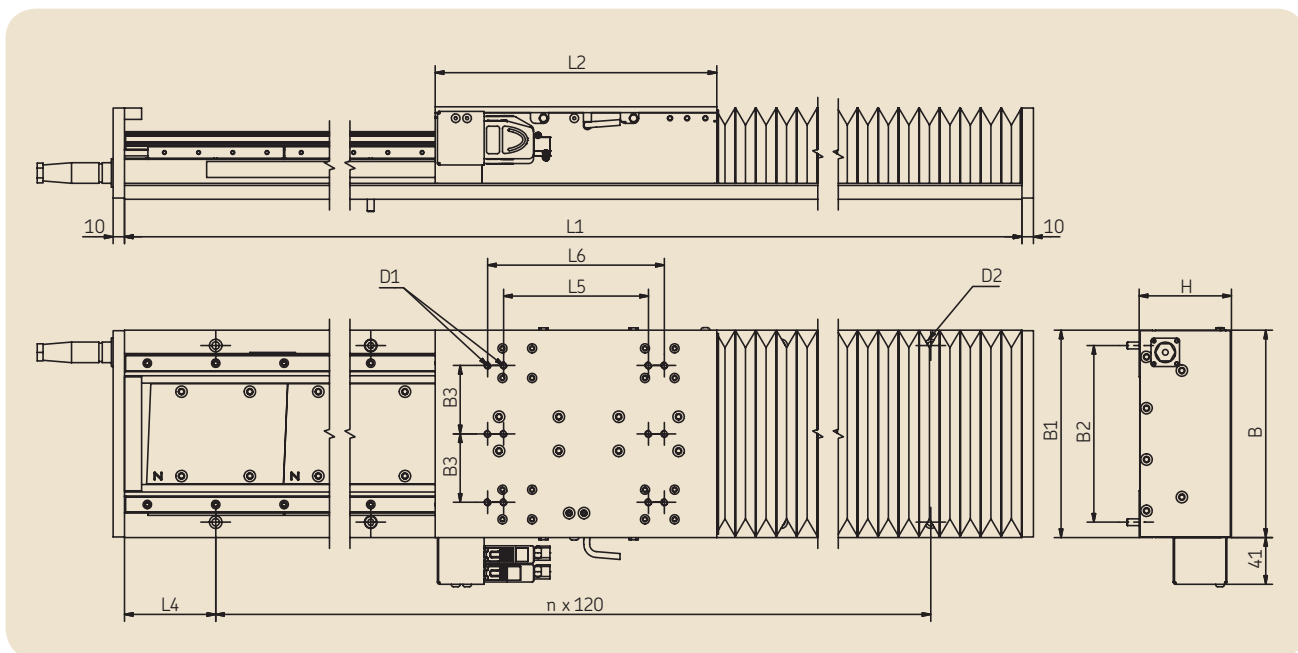

LTS dimensions

Typ LTS	Dimensions of slide											D1	D2
	B	H	L1	L2	L4	L5	L6	B1	B2	B3			
	mm											-	-
LTS 154.L1.1FN3-050-1.BL	154	81	280-1 960	142	80	118	-	154	127	2*60	M6	Km6	
LTS 154.L1.1FN3-050-2.BL	154	81	400-1 960	247	80	127	-	154	127	2*60	M6	Km6	
LTS 182.L1.1FN3-100-1.BL	182	81	280-1 960	142	80	118	-	182	155	2*60	M6	Km6	
LTS 182.L1.1FN3-100-2.BL	182	81	400-1 960	247	80	127	155	182	155	2*60	M6	Km6	
LTS 182.L1.1FN3-100-3.BL	182	81	520-1 960	352	80	127	155	182	155	2*60	M6	Km6	
LTS 212.L1.1FN3-150-1.BL	212	86	280-1 960	142	80	118	-	212	185	3*60	M6	Km6	
LTS 212.L1.1FN3-150-2.BL	212	86	400-1 960	247	80	155	185	212	185	3*60	M6	Km6	
LTS 212.L1.1FN3-150-3.BL	212	86	520-1 960	352	80	155	185	212	185	3*60	M6	Km6	

Strokes – LTS slide lengths

Base length	L1	mm	280	400	520	640	760	880	1 000	1 120	1 240	1 360	1 480	1 600	1 720	1 840	1 960
Motor size			1														
Top length	L2	mm	142														
maximum strokes with or without bellows:																	
with	S1	mm	95	180	270	360	450	535	625	720	810	895	985	1 075	1 160	1 250	1 340
without	S2	mm	108	228	348	468	588	708	828	948	1 068	1 188	1 308	1 428	1 548	1 668	1 788
Motor size			2														
Base length	L2	mm	247														
maximum strokes with or without bellows:																	
with	S1	mm	-	110	195	285	375	465	550	640	730	815	905	995	1 080	1 170	1 260
without	S2	mm	-	123	243	363	483	603	723	843	963	1 083	1 203	1 323	1 443	1 563	1 683
Motor size			3														
Base length	L2	mm	352														
maximum strokes with or without bellows:																	
with	S1	mm	-	-	115	205	295	385	470	560	650	735	825	915	1 000	1 090	1 180
without	S2	mm	-	-	138	258	378	498	618	738	858	978	1 098	1 218	1 338	1 458	1 578

Linear guidance

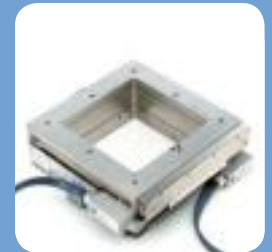
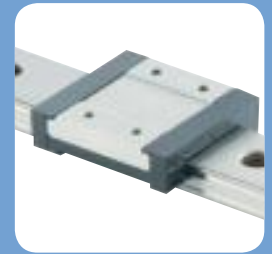

Contacts

Linear motion from SKF
www.linearmotion.skf.com

Represented by:

© SKF is a registered trademark of the SKF Group.

© SKF Group 2008

The contents of this publication are the copyright of the publisher and may not be reproduced (even extracts) unless prior written permission is granted. Every care has been taken to ensure the accuracy of the information contained in this publication but no liability can be accepted for any loss or damage whether direct, indirect or consequential arising out of the use of the information contained herein.

