

Precision ball bearings in tolerance grades ABEC-5 and ABEC-7 are recommended for applications where high speed and/or extreme running accuracy is required. These bearings have the same nominal external dimensions as equivalent size ABEC-1 grade bearings; however, the running characteristics and external dimensions are held to closer tolerances.

Standardization

Bearing envelope dimensions and tolerances shown in this catalog comply with standards established in the USA by the Annular Bearing Engineers Committee (ABEC) of the American Bearing Manufacturers Association (ABMA) (see Engineering section; page 239). These standards have also been approved by the American Standard Association (ASA) and the International Standards Organization (ISO). This assures the bearing user of all the advantages of dimensional standardization. However, dimensional interchangeability is not necessarily an indication of functional interchangeability. Other characteristics must also be considered such as cage type, internal clearance, contact angle, configuration of the bearing rings and other details.

In order to meet the running characteristic tolerances specified for precision bearings, it is necessary to assemble them with high precision balls where the size, sphericity and other surface characteristics are held to very close tolerances. Cages generally are of phenolic (bakelite) composition, which is well-suited for high-speed operation.

Temperature

The bearings are manufactured from vacuum-processed 52100 steel that can operate satisfactorily to 250°F (121°C). This is well within the requirement of most machine tool applications.

Duplex Bearings

Precision ball bearings are also duplex ground so they can be used as a component in a pair of bearings or in a bearing set (see Duplex Bearings section; page 234). Duplex pairs (or sets of bearings) ordered as DB, DF, or DT (or in combinations), are tied together as they are to be mounted.

Packaging and Identification

Bearings are thoroughly cleaned immediately prior to packaging and are usually coated with a lightweight oil compatible with most machine lubricants. Therefore, bearings can be used as received without being washed, with the oil serving as a rust inhibitor. Single-row bearings are packaged in hermetically sealed transparent bags and placed in distinctive boxes identified with the bearing number, tolerance grade and other important bearing data.

Size	Series	Page
1900R	Extremely Light, ABEC-7, Single Bearing	188
1900RD	Extremely Light, ABEC-7, Duplex Set	189
100KR	Extra Light, ABEC-7, Single Bearing	190
100KRD	Extra Light, ABEC-7, Duplex Set	191
200R	Light, ABEC-7, Single Bearing	192
200RD	Light, ABEC-7, Duplex Set	193
300R	Medium, ABEC-7, Single Bearing	194
300RD	Medium, ABEC-7, Duplex Set	195
200S	Light, ABEC-5, Woodworking Bearings	196
300S	Medium, ABEC-5, Woodworking Bearings	196
XO-RBDJ	Ball Screw Support Bearings	197
XO-RBDS	Excello Bearings	199

Precision 15° Angular Contact 1900-R Extremely Light Series (Single Bearings)

MRC Bearing Services

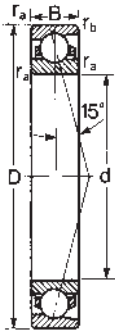

Precision 1900-R series angular contact ball bearings are manufactured to meet dimensional and running accuracy to ABEC-7 tolerances. They are supplied with an inner ring-centered phenolic cage designed to minimize centrifugal force.

For recommended mounting fits refer to "Shaft and Housing Fits" in Engineering Data Section.

For equivalent load and life calculations see pages 116 and 117.

MRC Bearing Number	Bore		Outside Diameter D		Width B		Fillet Radius ¹⁾				Basic Radial Load Rating				Speed Rating ³⁾			
											Dynamic C ²⁾		Static C ₀		Grease	Oil		
	d	mm	in	mm	in	mm	in	mm	in	mm	in	ZD ²	N	lbf	N	lbf	RPM	RPM
1900R	10	.3937	22	.8661	6	.2362	.30	.012	.10	.004	110	.17	3 120	701	1 560	351	76 000	110 000
1901R	12	.4724	24	.9449	6	.2362	.30	.012	.10	.004	123	.19	3 250	731	1 800	405	69 000	100 000
1902R	15	.5906	28	1.1024	7	.2756	.30	.012	.10	.004	187	.29	4 880	1 100	2 700	607	55 000	84 000
1903R	17	.6693	30	1.1811	7	.2756	.30	.012	.10	.004	206	.32	5 400	1 210	3 000	674	51 000	78 000
1904R	20	.7874	37	1.4567	9	.3543	.30	.012	.15	.006	400	.62	9 360	2 100	5 850	1 320	41 000	62 000
1905R	25	.9843	42	1.6535	9	.3543	.30	.012	.15	.006	342	.53	7 610	1 710	5 300	1 190	37 000	53 000
1906R	30	1.1811	47	1.8504	9	.3543	.30	.012	.15	.006	452	.70	9 750	2 190	7 100	1 600	32 000	48 000
1907R	35	1.3780	55	2.1654	10	.3937	.64	.025	.15	.006	555	.86	11 200	2 520	9 000	2 020	25 000	39 000
1908R	40	1.5748	62	2.4409	12	.4724	.64	.025	.15	.006	722	1.12	14 300	3 210	11 600	2 600	23 000	36 000
1909R	45	1.7717	68	2.6772	12	.4724	.64	.025	.15	.006	806	1.25	15 100	3 400	13 400	3 010	21 000	31 000
1910R	50	1.9685	72	2.8346	12	.4724	.64	.025	.15	.006	1 070	1.66	19 500	4 380	17 300	3 900	20 000	28 000
1911R	55	2.1654	80	3.1496	13	.5118	1.0	.04	.30	.012	1 260	1.95	22 900	5 150	20 400	4 590	18 000	27 000
1912R	60	2.3622	85	3.3465	13	.5118	1.0	.04	.30	.012	1 390	2.15	24 200	5 440	22 800	5 130	17 000	25 000
1913R	65	2.5591	90	3.5433	13	.5118	1.0	.04	.30	.012	1 450	2.25	24 700	5 550	24 000	5 400	15 000	22 000
1914R	70	2.7559	100	3.9370	16	.6299	1.0	.04	.30	.012	1 990	3.09	33 200	7 460	32 500	7 300	14 000	21 000
1915R	75	2.9528	105	4.1339	16	.6299	1.0	.04	.30	.012	2 080	3.23	34 500	7 760	34 500	7 760	14 000	20 000
1916R	80	3.1496	110	4.3307	16	.6299	1.0	.04	.30	.012	2 180	3.38	34 500	7 760	36 000	8 100	13 000	19 000
1917R	85	3.3465	120	4.7244	18	.7087	1.0	.04	.60	.024	2 840	4.40	44 900	10 100	46 500	10 500	12 000	18 000
1918R	90	3.5433	125	4.9213	18	.7087	1.0	.04	.60	.024	3 400	5.27	52 700	11 800	56 000	12 600	12 000	17 000
1919R	95	3.7402	130	5.1181	18	.7087	1.0	.04	.60	.024	3 090	4.79	47 500	10 700	52 000	11 700	11 000	16 000
1920R	100	3.9370	140	5.5118	20	.7874	1.0	.04	.60	.024	3 870	6.00	58 500	13 200	64 000	14 400	10 000	15 000
1921R	105	4.1339	145	5.7087	20	.7874	1.0	.04	.60	.024	4 030	6.25	60 500	13 600	67 000	15 100	10 000	14 000
1922R	110	4.3307	150	5.9055	20	.7874	1.0	.04	.60	.024	3 820	5.93	55 300	12 400	64 000	14 400	9 200	13 000
1924R	120	4.7244	165	6.4961	22	.8661	1.0	.04	.60	.024	5 100	7.91	74 100	16 700	85 000	19 100	8 300	12 000
1926R	130	5.1181	180	7.0866	24	.9449	1.5	.06	.60	.024	6 300	9.77	90 400	20 500	106 000	23 800	7 800	11 000
1928R	140	5.5118	190	7.4803	24	.9449	1.5	.06	.60	.024	6 580	10.2	95 600	21 400	110 000	24 700	7 400	11 000
1930R	150	5.9055	210	8.2677	28	1.1024	2.0	.08	1.0	.040	9 090	14.1	125 000	28 200	150 000	33 700	6 400	9 500
1932R	160	6.2992	220	8.6614	28	1.1024	2.0	.08	1.0	.040	9 420	14.6	127 000	28 600	156 000	35 100	6 000	9 000
1934R	170	6.6929	230	9.0551	28	1.1024	2.0	.08	1.0	.040	10 200	15.8	133 000	29 800	170 000	38 300	5 500	8 400
1936R	180	7.0866	250	9.8425	33	1.2992	2.0	.08	1.0	.040	12 800	19.9	168 000	36 000	212 000	47 800	5 100	7 800
1938R	190	7.4803	260	10.2362	33	1.2992	2.0	.08	1.0	.040	13 400	20.7	174 000	39 100	224 000	50 400	5 100	7 800
1940R	200	7.8740	280	11.0236	38	1.4961	2.0	.08	1.0	.040	16 800	26.0	216 000	48 600	275 000	61 800	4 600	7 300

¹⁾ Fillet radius indicates maximum fillet radius on shaft or in housing which bearing corner will clear.

²⁾ Rating for one million revolutions or 500 hours at 33 1/3 RPM.

³⁾ Values have been determined through historical application and practice. For a more complete explanation, see pg. 274.

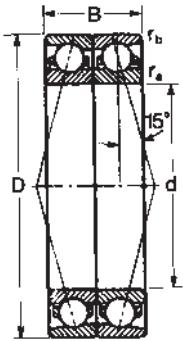

Precision 1900-RD series angular contact ball bearings are manufactured to meet dimensional and running accuracy to ABEC-7 tolerances. They are supplied with an inner ring-centered phenolic cage designed to minimize centrifugal force.

For recommended mounting fits refer to "Shaft and Housing Fits" in Engineering Data Section.

"D" indicates a duplex ground half pair matched with an identical half pair and is followed by an additional suffix letter to describe the type of duplex. See pages 234 and 235 for suffix description.

For equivalent load and life calculations see pages 118 and 119.

Use these values for back-to-back (DB) or face-to-face (DF) mounting arrangements.

MRC Bearing Number	Bore		Outside Diameter D		Width B		Fillet Radius ¹⁾				Basic Radial Load Rating				Speed Rating ³⁾			
											Dynamic C ²⁾		Static C ₀		Grease	Oil		
	mm	in	mm	in	mm	in	r _a mm	r _a in	r _b mm	r _b in	ZD ² mm	ZD ² in	N	lbf	N	lbf	RPM	RPM
1900RD	10	.3937	22	.8661	12	.4724	.30	.012	.10	.004	110	.17	5 070	1 140	3 100	697	61 000	88 000
1901RD	12	.4724	24	.9449	12	.4724	.30	.012	.10	.004	123	.19	5 270	1 180	3 550	798	55 000	80 000
1902RD	15	.5906	28	1.1024	14	.5512	.30	.012	.10	.004	187	.29	7 930	1 780	5 400	1 210	44 000	67 000
1903RD	17	.6693	30	1.1811	14	.5512	.30	.012	.10	.004	206	.32	8 710	1 960	6 100	1 370	41 000	62 000
1904RD	20	.7874	37	1.4567	18	.7087	.30	.012	.15	.006	400	.62	15 300	3 440	11 600	2 600	33 000	50 000
1905RD	25	.9843	42	1.6535	18	.7087	.30	.012	.15	.006	342	.53	12 400	2 790	10 800	2 430	30 000	42 000
1906RD	30	1.1811	47	1.8504	18	.7087	.30	.012	.15	.006	452	.70	15 900	3 580	14 300	3 210	26 000	38 000
1907RD	35	1.3780	55	2.1654	20	.7874	.64	.025	.15	.006	555	.86	18 200	4 090	18 000	4 050	20 000	31 000
1908RD	40	1.5748	62	2.4409	24	.9449	.64	.025	.15	.006	722	1.12	22 900	5 150	23 200	5 220	18 000	29 000
1909RD	45	1.7717	68	2.6772	24	.9449	.64	.025	.15	.006	806	1.25	24 700	5 550	26 500	5 960	17 000	25 000
1910RD	50	1.9685	72	2.8346	24	.9449	.64	.025	.15	.006	1 070	1.66	31 900	7 170	34 500	7 760	16 000	22 000
1911RD	55	2.1654	80	3.1496	26	1.0236	1.0	.04	.30	.012	1 260	1.95	37 100	8 340	40 500	9 100	14 000	22 000
1912RD	60	2.3622	85	3.3465	26	1.0236	1.0	.04	.30	.012	1 390	2.15	39 000	8 770	45 500	10 200	14 000	20 000
1913RD	65	2.5591	90	3.5433	26	1.0236	1.0	.04	.30	.012	1 450	2.25	39 700	8 920	48 000	10 800	12 000	18 000
1914RD	70	2.7559	100	3.9370	32	1.2598	1.0	.04	.30	.012	1 990	3.09	54 000	12 100	65 500	14 700	11 000	17 000
1915RD	75	2.9528	105	4.1339	32	1.2598	1.0	.04	.30	.012	2 080	3.23	55 900	12 600	68 000	15 300	11 000	16 000
1916RD	80	3.1496	110	4.3307	32	1.2598	1.0	.04	.30	.012	2 180	3.38	57 200	12 900	72 000	16 200	10 000	15 000
1917RD	85	3.3465	120	4.7244	36	1.4173	1.0	.04	.60	.024	2 840	4.40	74 100	16 700	93 000	20 900	9 600	14 000
1918RD	90	3.5433	125	4.9213	36	1.4173	1.0	.04	.60	.024	3 400	5.27	85 200	19 200	112 000	25 200	9 600	14 000
1919RD	95	3.7402	130	5.1181	36	1.4173	1.0	.04	.60	.024	3 090	4.79	76 100	17 100	104 000	23 400	8 800	13 000
1920RD	100	3.9370	140	5.5118	40	1.5748	1.0	.04	.60	.024	3 870	6.00	95 600	21 500	127 000	28 600	8 000	12 000
1921RD	105	4.1339	145	5.7087	40	1.5748	1.0	.04	.60	.024	4 030	6.25	97 500	21 900	134 000	30 100	8 000	11 000
1922RD	110	4.3307	150	5.9055	40	1.5748	1.0	.04	.60	.024	3 820	5.93	90 400	20 300	129 000	29 000	7 400	10 000
1924RD	120	4.7244	165	6.4961	44	1.7323	1.0	.04	.60	.024	5 100	7.91	121 000	27 200	170 000	38 200	6 600	9 600
1926RD	130	5.1181	180	7.0866	48	1.8898	1.5	.06	.60	.024	6 300	9.77	146 000	32 800	208 000	46 800	6 200	8 800
1928RD	140	5.5118	190	7.4803	48	1.8898	1.5	.06	.60	.024	6 580	10.2	156 000	35 100	220 000	49 500	5 900	8 800
1930RD	150	5.9055	210	8.2677	56	2.2047	2.0	.08	1.0	.040	9 090	14.1	203 000	45 600	300 000	67 400	5 100	7 600
1932RD	160	6.2992	220	8.6614	56	2.2047	2.0	.08	1.0	.040	9 420	14.6	208 000	46 800	315 000	70 800	4 800	7 200
1934RD	170	6.6929	230	9.0551	56	2.2047	2.0	.08	1.0	.040	10 200	15.8	216 000	48 600	340 000	76 400	4 400	6 700
1936RD	180	7.0866	250	9.8425	66	2.5984	2.0	.08	1.0	.040	12 800	19.9	276 000	62 000	425 000	95 600	4 100	6 200
1938RD	190	7.4803	260	10.2362	66	2.5984	2.0	.08	1.0	.040	13 400	20.7	281 000	63 200	440 000	98 900	4 100	6 200
1940RD	200	7.8740	280	11.0236	76	2.9921	2.0	.08	1.0	.040	16 800	26.0	351 000	78 900	550 000	124 000	3 700	5 800

¹⁾ Fillet radius indicates maximum fillet radius on shaft or in housing which bearing corner will clear.

²⁾ Rating for one million revolutions or 500 hours at 33 1/3 RPM.

³⁾ Values have been determined through historical application and practice. For a more complete explanation, see pg. 274.

**Precision 15° Angular Contact
100-KR Extra Light Series
(Single Bearings)**

MRC Bearing Services

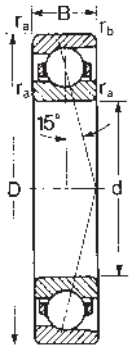

Precision 100-KR series angular contact ball bearings are manufactured to meet dimensional and running accuracy to ABEC-7 tolerances. They are supplied with an inner ring-centered phenolic cage designed to minimize centrifugal force.

For recommended mounting fits refer to "Shaft and Housing Fits" in Engineering Data Section.

For equivalent load and life calculations see pages 116 and 117.

MRC Bearing Number	Bore		Outside Diameter D		Width B		Fillet Radius ¹⁾				Basic Radial Load Rating				Speed Rating ³⁾			
											Dynamic C ²⁾		Static C ₀		Grease	Oil		
	d	mm	in	mm	in	mm	in	r _a	r _b	ZD ²	N	lbf	N	lbf	RPM	RPM		
100KR	10	.3937	26	1.0236	8	.3150	.30	.012	.10	.004	181	.28	4 940	1 110	2 280	513	69 000	100 000
101KR	12	.4724	28	1.1024	8	.3150	.30	.012	.10	.004	206	.32	5 530	1 240	2 650	596	60 000	90 000
102KR	15	.5906	32	1.2598	9	.3543	.30	.012	.10	.004	226	.35	6 050	1 350	3 150	708	51 000	78 000
103KR	17	.6693	35	1.3780	10	.3937	.30	.012	.10	.004	342	.53	8 520	1 920	4 650	1 050	44 000	67 000
104KR	20	.7874	42	1.6535	12	.4724	.64	.025	.30	.012	445	.69	10 800	2 420	6 200	1 390	39 000	56 000
105KR	25	.9843	47	1.8504	12	.4724	.64	.025	.30	.012	522	.81	12 100	2 720	7 650	1 720	35 000	50 000
106KR	30	1.1811	55	2.1654	13	.5118	1.0	.04	.30	.012	716	1.11	15 600	3 500	10 600	2 380	28 000	42 000
107KR	35	1.3780	62	2.4409	14	.5512	1.0	.04	.30	.012	884	1.37	18 600	4 180	13 200	2 970	23 000	36 000
108KR	40	1.5748	68	2.6772	15	.5906	1.0	.04	.30	.012	942	1.46	19 500	4 380	14 600	3 280	22 000	34 000
109KR	45	1.7717	75	2.9528	16	.6299	1.0	.04	.30	.012	1 220	1.89	24 200	5 440	19 000	4 270	21 000	31 000
110KR	50	1.9685	80	3.1496	16	.6299	1.0	.04	.30	.012	1 300	2.01	25 100	5 640	20 400	4 590	20 000	28 000
111KR	55	2.1654	90	3.5433	18	.7087	1.0	.04	.60	.024	1 810	2.81	33 800	7 600	28 000	6 290	17 000	25 000
112KR	60	2.3622	95	3.7402	18	.7087	1.0	.04	.60	.024	1 920	2.97	35 100	7 890	30 000	6 740	15 000	22 000
113KR	65	2.5591	100	3.9370	18	.7087	1.0	.04	.60	.024	2 030	3.14	35 800	8 050	32 500	7 310	14 000	21 000
114KR	70	2.7559	110	4.3307	20	.7874	1.0	.04	.60	.024	2 470	3.83	42 300	9 510	40 000	8 990	14 000	20 000
115KR	75	2.9528	115	4.5276	20	.7874	1.0	.04	.60	.024	2 590	4.02	43 600	9 800	42 500	9 550	13 000	19 000
116KR	80	3.1496	125	4.9213	22	.8661	1.0	.04	.60	.024	3 390	5.25	55 900	12 600	54 000	12 100	12 000	18 000
117KR	85	3.3465	130	5.1181	22	.8661	1.0	.04	.60	.024	3 550	5.50	57 200	12 900	57 000	12 800	12 000	17 000
118KR	90	3.5433	140	5.5118	24	.9449	1.5	.06	.60	.024	4 280	6.64	68 900	15 500	68 000	15 300	11 000	16 000
119KR	95	3.7402	145	5.7087	24	.9449	1.5	.06	.60	.024	5 040	7.81	83 200	18 700	80 000	18 000	10 000	15 000
120KR	100	3.9370	150	5.9055	24	.9449	1.5	.06	.60	.024	4 700	7.28	71 500	16 100	76 500	17 200	10 000	14 000
121KR	105	4.1339	160	6.2992	26	1.0236	2.0	.08	1.0	.040	5 540	8.59	85 200	19 200	90 000	20 200	9 200	13 000
122KR	110	4.3307	170	6.6929	28	1.1024	2.0	.08	1.0	.040	6 400	9.93	99 500	22 400	102 000	23 000	8 700	13 000
124KR	120	4.7244	180	7.0866	28	1.1024	2.0	.08	1.0	.040	6 710	10.4	101 000	22 600	110 000	24 700	7 800	11 000
126KR	130	5.1181	200	7.8740	33	1.2992	2.0	.08	1.0	.040	9 350	14.5	138 000	31 000	150 000	33 700	7 400	11 000
128KR	140	5.5118	210	8.2677	33	1.2992	2.0	.08	1.0	.040	9 350	14.5	135 000	30 300	153 000	34 400	6 900	10 000
130KR	150	5.9055	225	8.8583	35	1.3780	2.0	.08	1.0	.040	10 800	16.8	156 000	35 000	176 000	39 600	6 000	9 000
132KR	160	6.2992	240	9.4488	38	1.4961	2.0	.08	1.0	.040	12 400	19.3	178 000	40 000	204 000	45 900	5 500	8 400
134KR	170	6.6929	260	10.2362	42	1.6535	2.0	.08	1.0	.040	15 300	23.7	212 000	47 700	245 000	55 100	5 100	7 800
136KR	180	7.0866	280	11.0236	46	1.8110	2.0	.08	1.0	.040	17 900	27.8	234 000	52 600	290 000	65 200	4 600	7 300
138KR	190	7.4803	290	11.4173	46	1.8110	2.0	.08	1.0	.040	18 800	29.1	242 000	54 400	305 000	68 600	4 600	7 300
140KR	200	7.8740	310	12.2047	51	2.0079	2.0	.08	1.0	.040	22 200	34.4	276 000	62 000	355 000	79 800	4 400	6 700
144KR	220	8.6614	340	13.3858	56	2.2047	2.5	.10	1.0	.040	30 400	47.2	345 000	77 600	480 000	108 000	4 100	6 200
148KR	240	9.4488	360	14.1732	56	2.2047	2.5	.10	1.0	.040	31 900	49.5	351 000	78 900	510 000	115 000	3 900	5 600

¹⁾ Fillet radius indicates maximum fillet radius on shaft or in housing which bearing corner will clear.

²⁾ Rating for one million revolutions or 500 hours at 33 1/3 RPM.

³⁾ Values have been determined through historical application and practice. For a more complete explanation, see pg. 274.

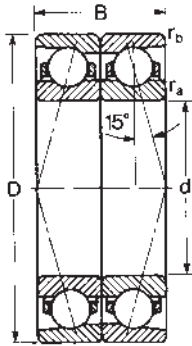

Precision 100-KRD series angular contact ball bearings are manufactured to meet dimensional and running accuracy to ABEC-7 tolerances. They are supplied with an inner ring-centered phenolic cage designed to minimize centrifugal force.

For recommended mounting fits refer to "Shaft and Housing Fits" in Engineering Data Section.

"D" indicates a duplex ground half pair matched with an identical half pair and is followed by an additional suffix letter to describe the type of duplex. See pages 234 and 235 for suffix description.

For equivalent load and life calculations see pages 118 and 119.

Use these values for back-to-back (DB) or face-to-face (DF) mounting arrangements.

MRC Bearing Number	Bore		Outside Diameter D		Width B		Fillet Radius ¹⁾				ZD ²⁾		Basic Radial Load Rating		Speed Rating ³⁾			
													Dynamic C _d ²⁾		Static C ₀		Grease RPM	Oil RPM
	d	mm	in	mm	in	mm	in	r _a	r _b	mm	in	N	lbf	N	lbf	RPM	RPM	
100KRD	10	.3937	26	1.0236	16	.6299	.30	.012	.10	.004	181	.28	8 060	1 810	4 550	1 020	55 000	80 000
101KRD	12	.4724	28	1.1024	16	.6299	.30	.012	.10	.004	206	.32	8 840	1 990	5 300	1 190	48 000	72 000
102KRD	15	.5906	32	1.2598	18	.7087	.30	.012	.10	.004	226	.35	9 750	2 190	6 300	1 420	41 000	62 000
103KRD	17	.6693	35	1.3780	20	.7874	.30	.012	.10	.004	342	.53	13 800	3 100	9 300	2 090	35 000	54 000
104KRD	20	.7874	42	1.6535	24	.9449	.64	.025	.30	.012	445	.69	17 400	3 910	12 500	2 810	31 000	45 000
105KRD	25	.9843	47	1.8504	24	.9449	.64	.025	.30	.012	522	.81	19 500	4 380	15 300	3 440	28 000	40 000
106KRD	30	1.1811	55	2.1654	26	1.0236	1.0	.04	.30	.012	716	1.11	25 500	5 730	21 200	4 760	22 000	34 000
107KRD	35	1.3780	62	2.4409	28	1.1024	1.0	.04	.30	.012	884	1.37	30 200	6 790	26 500	5 960	18 000	29 000
108KRD	40	1.5748	68	2.6772	30	1.1811	1.0	.04	.30	.012	942	1.46	31 900	7 170	29 000	6 520	18 000	27 000
109KRD	45	1.7717	75	2.9528	32	1.2598	1.0	.04	.30	.012	1 220	1.89	39 000	8 770	37 500	8 430	17 000	25 000
110KRD	50	1.9685	80	3.1496	32	1.2598	1.0	.04	.30	.012	1 300	2.01	40 300	9 060	40 500	9 100	16 000	22 000
111KRD	55	2.1654	90	3.5433	36	1.4173	1.0	.04	.60	.024	1 810	2.81	55 300	12 400	56 000	12 600	14 000	20 000
112KRD	60	2.3622	95	3.7402	36	1.4173	1.0	.04	.60	.024	1 920	2.97	55 900	12 600	61 000	13 700	12 000	18 000
113KRD	65	2.5591	100	3.9370	36	1.4173	1.0	.04	.60	.024	2 030	3.14	58 500	13 200	64 000	14 400	11 000	17 000
114KRD	70	2.7559	110	4.3307	40	1.5748	1.0	.04	.60	.024	2 470	3.83	68 900	15 500	80 000	18 000	11 000	16 000
115KRD	75	2.9528	115	4.5276	40	1.5748	1.0	.04	.60	.024	2 590	4.02	70 200	15 800	85 000	19 100	10 000	15 000
116KRD	80	3.1496	125	4.9213	44	1.7323	1.0	.04	.60	.024	3 390	5.25	90 400	20 300	110 000	24 700	9 600	14 000
117KRD	85	3.3465	130	5.1181	44	1.7323	1.0	.04	.60	.024	3 550	5.50	92 300	20 700	116 000	26 100	9 600	14 000
118KRD	90	3.5433	140	5.5118	48	1.8898	1.5	.06	.60	.024	4 280	6.64	111 000	25 000	137 000	30 800	8 800	13 000
119KRD	95	3.7402	145	5.7087	48	1.8898	1.5	.06	.60	.024	5 040	7.81	135 000	30 300	160 000	36 000	8 000	12 000
120KRD	100	3.9370	150	5.9055	48	1.8898	1.5	.06	.60	.024	4 700	7.28	117 000	26 300	153 000	34 400	8 000	11 000
121KRD	105	4.1339	160	6.2992	52	2.0472	2.0	.08	1.0	.040	5 540	8.59	138 000	31 000	180 000	40 500	7 400	10 000
122KRD	110	4.3307	170	6.6929	56	2.2047	2.0	.08	1.0	.040	6 400	9.93	163 000	36 600	204 000	45 900	7 000	10 000
124KRD	120	4.7244	180	7.0866	56	2.2047	2.0	.08	1.0	.040	6 710	10.4	163 000	36 600	220 000	49 500	6 200	8 800
126KRD	130	5.1181	200	7.8740	66	2.5984	2.0	.08	1.0	.040	9 350	14.5	225 000	50 000	300 000	67 400	5 900	8 800
128KRD	140	5.5118	210	8.2677	66	2.5984	2.0	.08	1.0	.040	9 350	14.5	221 000	49 700	305 000	68 600	5 500	8 000
130KRD	150	5.9055	225	8.8583	70	2.7559	2.0	.08	1.0	.040	10 800	16.8	255 000	57 300	355 000	79 800	4 800	7 200
132KRD	160	6.2992	240	9.4488	76	2.9921	2.0	.08	1.0	.040	12 400	19.3	286 000	64 300	405 000	91 000	4 400	6 700
134KRD	170	6.6929	260	10.2362	84	3.3071	2.0	.08	1.0	.040	15 300	23.7	345 000	77 600	490 000	110 000	4 100	6 200
136KRD	180	7.0866	280	11.0236	92	3.6220	2.0	.08	1.0	.040	17 900	27.8	377 000	84 800	570 000	128 000	3 700	5 800
138KRD	190	7.4803	290	11.4173	92	3.6220	2.0	.08	1.0	.040	18 800	29.1	390 000	87 700	610 000	137 000	3 700	5 800
140KRD	200	7.8740	310	12.2047	102	4.0157	2.0	.08	1.0	.040	22 200	34.4	442 000	99 400	710 000	160 000	3 500	5 400
144KRD	220	8.6614	340	13.3858	112	4.4094	2.5	.10	1.0	.040	30 400	47.2	559 000	126 000	965 000	217 000	3 300	5 000
148KRD	240	9.4488	360	14.1732	112	4.4094	2.5	.10	1.0	.040	31 900	49.5	572 000	129 000	1 020 000	228 000	3 100	4 500

¹⁾ Fillet radius indicates maximum fillet radius on shaft or in housing which bearing corner will clear.

²⁾ Rating for one million revolutions or 500 hours at 33 1/3 RPM.

³⁾ Values have been determined through historical application and practice. For a more complete explanation, see pg. 274.

**Precision 15° Angular Contact
200-R Light Series
(Single Bearings)**

MRC Bearing Services

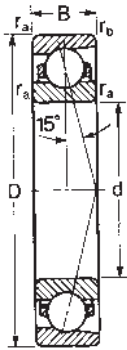

Precision 200-R series angular contact ball bearings are manufactured to meet dimensional and running accuracy to ABEC-7 tolerances. They are supplied with an inner ring centered phenolic cage designed to minimize centrifugal force.

For recommended mounting fits refer to "Shaft and Housing Fits" in Engineering Data Section

For equivalent load and life calculations see pages 116 and 117.

MRC Bearing Number	Bore		Outside Diameter D		Width B		Fillet Radius ¹⁾				Basic Radial Load Rating				Speed Rating ³⁾			
											Dynamic C ²⁾		Static C ₀		Grease RPM	Oil RPM		
	mm	in	mm	in	mm	in	mm	in	mm	in	N	lbf	N	lbf				
200R	10	.3937	30	1.1811	9	.3543	.64	.025	.30	.012	284	.44	7 280	1 640	3 200	719	55 000	84 000
201R	12	.4724	32	1.2598	10	.3937	.64	.025	.30	.012	323	.50	8 190	1 840	3 900	877	51 000	78 000
202R	15	.5906	35	1.3780	11	.4331	.64	.025	.30	.012	406	.63	9 750	2 190	5 100	1 150	44 000	67 000
203R	17	.6693	40	1.5748	12	.4724	.64	.025	.30	.012	510	.79	12 100	2 730	6 550	1 470	39 000	56 000
204R	20	.7874	47	1.8504	14	.5512	1.0	.04	.60	.024	562	.87	13 300	2 990	7 800	1 750	35 000	50 000
205R	25	.9843	52	2.0472	15	.5906	1.0	.04	.60	.024	693	1.07	15 900	3 570	9 650	2 170	28 000	42 000
206R	30	1.1811	62	2.4409	16	.6299	1.0	.04	.60	.024	884	1.37	19 000	4 270	12 900	2 910	23 000	36 000
207R	35	1.3780	72	2.8346	17	.6693	1.0	.04	.60	.024	1 270	1.97	26 000	5 850	18 600	4 180	21 000	31 000
208R	40	1.5748	80	3.1496	18	.7087	1.0	.04	.60	.024	1 730	2.68	34 500	7 760	25 000	5 620	20 000	28 000
209R	45	1.7717	85	3.3465	19	.7480	1.0	.04	.60	.024	1 850	2.87	35 800	8 050	27 500	6 180	17 000	25 000
210R	50	1.9685	90	3.5433	20	.7874	1.0	.04	.60	.024	1 970	3.06	37 700	8 480	30 000	6 740	16 000	24 000
211R	55	2.1654	100	3.9370	21	.8268	1.5	.06	1.0	.040	2 860	4.43	54 000	12 100	41 500	9 330	14 000	21 000
212R	60	2.3622	110	4.3307	22	.8661	1.5	.06	1.0	.040	3 260	5.06	59 200	13 300	49 000	11 000	14 000	20 000
213R	65	2.5591	120	4.7244	23	.9055	1.5	.06	1.0	.040	3 780	5.86	58 500	13 200	55 000	12 400	12 000	18 000
214R	70	2.7559	125	4.9213	24	.9449	1.5	.06	1.0	.040	4 030	6.25	71 500	16 100	60 000	13 500	12 000	17 000
215R	75	2.9528	130	5.1181	25	.9843	1.5	.06	1.0	.040	4 880	7.56	85 200	19 200	72 000	16 200	11 000	16 000
216R	80	3.1496	140	5.5118	26	1.0236	2.0	.08	1.0	.040	5 180	8.04	90 400	20 300	78 000	17 500	10 000	15 000
217R	85	3.3465	150	5.9055	28	1.1024	2.0	.08	1.0	.040	6 170	9.56	104 000	23 400	93 000	20 900	10 000	14 000
218R	90	3.5433	160	6.2992	30	1.1811	2.0	.08	1.0	.040	7 410	11.5	124 000	27 900	108 000	24 300	8 700	13 000
219R	95	3.7402	170	6.6929	32	1.2598	2.0	.08	1.0	.040	7 900	12.3	133 000	29 900	118 000	26 500	8 300	12 000
220R	100	3.9370	180	7.0866	34	1.3386	2.0	.08	1.0	.040	9 070	14.1	146 000	32 800	134 000	30 100	7 800	11 000
221R	105	4.1339	190	7.4803	36	1.4173	2.0	.08	1.0	.040	10 300	16.0	168 000	37 800	153 000	34 400	7 400	11 000
222R	110	4.3307	200	7.8740	38	1.4961	2.0	.08	1.0	.040	11 700	18.1	182 000	40 900	170 000	38 200	6 900	10 000
224R	120	4.7244	215	8.4646	40	1.5748	2.0	.08	1.0	.040	13 000	20.2	199 000	44 700	193 000	43 300	6 400	9 500
226R	130	5.1181	230	9.0551	40	1.5748	2.5	.10	1.0	.040	15 500	24.0	221 000	49 600	232 000	52 200	6 000	9 000

¹⁾ Fillet radius indicates maximum fillet radius on shaft or in housing which bearing corner will clear.

²⁾ Rating for one million revolutions or 500 hours at 33 1/3 RPM.

³⁾ Values have been determined through historical application and practice. For a more complete explanation, see pg. 274.

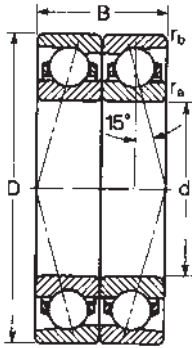

Precision 200-RD series angular contact ball bearings are manufactured to meet dimensional and running accuracy to ABEC-7 tolerances. They are supplied with an inner ring centered phenolic cage designed to minimize centrifugal force.

For recommended mounting fits refer to "Shaft and Housing Fits" in Engineering Data Section.

"D" indicates a duplex ground half pair matched with an identical half pair and is followed by an additional suffix letter to describe the type of duplex. See pages 234 and 235 for suffix description.

For equivalent load and life calculations see pages 118 and 119.

Use these values for back-to-back (DB) or face-to-face (DF) mounting arrangements.

MRC Bearing Number	Bore d		Outside Diameter D		Width B		Fillet Radius ¹⁾				Basic Radial Load Rating				Speed Rating ³⁾			
											Dynamic C ²⁾		Static C ₀		Grease RPM	Oil RPM		
											N	lbf	N	lbf				
	mm	in	mm	in	mm	in	r _a mm	r _a in	r _b mm	r _b in	ZD ² mm	ZD ² in	N	lbf	N	lbf		
200RD	10	.3937	30	1.1811	18	.7087	.64	.025	.30	.012	284	.44	11 900	2 680	6 400	1 440	44 000	67 000
201RD	12	.4724	32	1.2598	20	.7874	.64	.025	.30	.012	323	.50	13 300	2 990	7 800	1 750	41 000	62 000
202RD	15	.5906	35	1.3780	22	.8661	.64	.025	.30	.012	406	.63	15 900	3 570	10 200	2 290	35 000	54 000
203RD	17	.6693	40	1.5748	24	.9449	.64	.025	.30	.012	510	.79	19 900	4 470	13 200	2 970	31 000	45 000
204RD	20	.7874	47	1.8504	28	1.1024	1.0	.04	.60	.024	562	.87	21 600	4 860	15 600	3 510	28 000	40 000
205RD	25	.9843	52	2.0472	30	1.1811	1.0	.04	.60	.024	693	1.07	26 000	5 850	19 300	4 340	22 000	34 000
206RD	30	1.1811	62	2.4409	32	1.2598	1.0	.04	.60	.024	884	1.37	30 700	6 900	26 000	5 850	18 000	29 000
207RD	35	1.3780	72	2.8346	34	1.3386	1.0	.04	.60	.024	1 270	1.97	42 300	9 570	37 500	8 430	17 000	25 000
208RD	40	1.5748	80	3.1496	36	1.4173	1.0	.04	.60	.024	1 730	2.68	55 900	12 600	50 000	11 200	16 000	22 000
209RD	45	1.7717	85	3.3465	38	1.4961	1.0	.04	.60	.024	1 850	2.87	58 500	13 200	55 000	12 400	14 000	20 000
210RD	50	1.9685	90	3.5433	40	1.5748	1.0	.04	.60	.024	1 970	3.06	60 500	13 600	60 000	13 500	13 000	19 000
211RD	55	2.1654	100	3.9370	42	1.6535	1.5	.06	1.0	.040	2 860	4.43	87 100	19 600	83 000	18 700	11 000	17 000
212RD	60	2.3622	110	4.3307	44	1.7323	1.5	.06	1.0	.040	3 260	5.06	95 600	21 500	98 000	22 000	11 000	16 000
213RD	65	2.5591	120	4.7244	46	1.8110	1.5	.06	1.0	.040	3 780	5.86	95 600	21 500	110 000	24 700	9 600	14 000
214RD	70	2.7559	125	4.9213	48	1.8898	1.5	.06	1.0	.040	4 030	6.25	117 000	26 300	120 000	27 000	9 600	14 000
215RD	75	2.9528	130	5.1181	50	1.9685	1.5	.06	1.0	.040	4 880	7.56	138 000	31 000	148 000	32 100	8 800	13 000
216RD	80	3.1496	140	5.5118	52	2.0472	2.0	.08	1.0	.040	5 180	8.04	153 000	34 400	156 000	35 100	8 000	12 000
217RD	85	3.3465	150	5.9055	56	2.2047	2.0	.08	1.0	.040	6 170	9.56	168 000	37 800	186 000	41 800	8 000	11 000
218RD	90	3.5433	160	6.2992	60	2.3622	2.0	.08	1.0	.040	7 410	11.5	203 000	45 600	216 000	48 600	7 000	10 000
219RD	95	3.7402	170	6.6929	64	2.5197	2.0	.08	1.0	.040	7 900	12.3	216 000	48 600	236 000	53 100	6 600	9 600
220RD	100	3.9370	180	7.0866	68	2.6772	2.0	.08	1.0	.040	9 070	14.1	238 000	53 500	270 000	60 700	6 200	8 800
221RD	105	4.1339	190	7.4803	72	2.8346	2.0	.08	1.0	.040	10 300	16.0	270 000	60 700	305 000	68 600	5 900	8 800
222RD	110	4.3307	200	7.8740	76	2.9921	2.0	.08	1.0	.040	11 700	18.1	296 000	66 500	340 000	76 400	5 500	8 000
224RD	120	4.7244	215	8.4646	80	3.1496	2.0	.08	1.0	.040	13 000	20.2	325 000	73 100	390 000	87 700	5 100	7 600
226RD	130	5.1181	230	9.0551	80	3.1496	2.5	.10	1.0	.040	15 500	24.0	358 000	80 500	465 000	105 000	4 800	7 200

¹⁾ Fillet radius indicates maximum fillet radius on shaft or in housing which bearing corner will clear.

²⁾ Rating for one million revolutions or 500 hours at 33 1/3 RPM.

³⁾ Values have been determined through historical application and practice. For a more complete explanation, see pg. 274.

**Precision 15° Angular Contact
300-R Medium Series
(Single Bearings)**

MRC Bearing Services

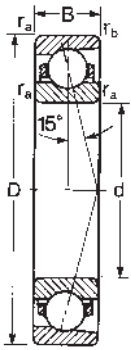

Precision 300-R series angular contact ball bearings are manufactured to meet dimensional and running accuracy to ABEC-7 tolerances. They are supplied with an inner ring centered phenolic cage designed to minimize centrifugal force.

For recommended mounting fits refer to "Shaft and Housing Fits" in Engineering Data Section.

For equivalent load and life calculations see pages 116 and 117.

MRC Bearing Number	Bore		Outside Diameter D		Width B		Fillet Radius ¹⁾					Basic Radial Load Rating				Speed Rating ³⁾		
												Dynamic C ²⁾		Static C ₀		Grease RPM	Oil RPM	
	d mm	d in	D mm	D in	B mm	B in	r _a mm	r _a in	r _b mm	r _b in	ZD ² mm	ZD ² in	N	lbf	N			lbf
300R	10	.3937	35	1.3780	11	.4331	1.0	.04	.60	.024	439	.68	10 500	2 360	4 550	1 020	46 000	73 000
301R	12	.4724	37	1.4567	12	.4724	1.0	.04	.60	.024	439	.68	10 600	2 380	4 900	1 100	44 000	67 000
302R	15	.5906	42	1.6535	13	.5118	1.0	.04	.60	.024	510	.79	12 100	2 720	6 550	1 470	39 000	56 000
303R	17	.6693	47	1.8504	14	.5512	1.0	.04	.60	.024	632	.98	14 800	3 330	8 150	1 830	37 000	53 000
304R	20	.7874	52	2.0472	15	.5906	1.0	.04	.60	.024	909	1.41	20 300	4 560	11 400	2 560	30 000	45 000
305R	25	.9843	62	2.4409	17	.6693	1.0	.04	.60	.024	1 090	1.69	23 400	5 260	15 300	3 440	25 000	39 000
306R	30	1.1811	72	2.8346	19	.7480	1.0	.04	.60	.024	1 480	2.30	31 200	7 010	20 000	4 500	21 000	31 000
307R	35	1.3780	80	3.1496	21	.8268	1.5	.06	1.0	.040	1 940	3.00	39 700	8 920	26 000	5 850	20 000	28 000
308R	40	1.5748	90	3.5433	23	.9055	1.5	.06	1.0	.040	2 450	3.80	48 800	11 000	33 500	7 530	17 000	25 000
309R	45	1.7717	100	3.9370	25	.9843	1.5	.06	1.0	.040	3 030	4.69	58 500	13 200	40 500	9 100	15 000	22 000
310R	50	1.9685	110	4.3307	27	1.0630	2.0	.08	1.0	.040	3 990	6.19	76 100	17 100	52 000	11 700	14 000	21 000
311R	55	2.1654	120	4.7244	29	1.1417	2.0	.08	1.0	.040	4 690	7.26	88 400	19 900	61 000	13 700	13 000	19 000
312R	60	2.3622	130	5.1181	31	1.2205	2.0	.08	1.0	.040	5 430	8.42	101 000	22 700	71 000	16 000	12 000	17 000
313R	65	2.5591	140	5.5118	33	1.2992	2.0	.08	1.0	.040	5 930	9.19	108 000	24 300	80 000	18 000	11 000	16 000
314R	70	2.7559	150	5.9055	35	1.3780	2.0	.08	1.0	.040	6 770	10.5	121 000	27 200	93 000	20 900	10 000	15 000
315R	75	2.9528	160	6.2992	37	1.4567	2.0	.08	1.0	.040	8 390	13.0	146 000	32 800	114 000	25 600	9 900	14 000
316R	80	3.1496	170	6.6929	39	1.5354	2.0	.08	1.0	.040	9 480	14.7	159 000	35 700	129 000	29 000	8 700	13 000
317R	85	3.3465	180	7.0866	41	1.6142	2.5	.10	1.0	.040	10 600	16.5	174 000	39 100	146 000	32 800	8 300	12 000
318R	90	3.5433	190	7.4803	43	1.6929	2.5	.10	1.0	.040	11 800	18.3	186 000	41 800	160 000	36 000	7 800	11 000
319R	95	3.7402	200	7.8740	45	1.7717	2.5	.10	1.0	.040	13 100	20.3	199 000	44 700	180 000	40 500	7 400	11 000
320R	100	3.9370	215	8.4646	47	1.8504	2.5	.10	1.0	.040	14 400	22.4	212 000	47 700	200 000	45 000	6 900	10 000
321R	105	4.1339	225	8.8583	49	1.9291	2.5	.10	1.0	.040	15 900	24.6	229 000	51 500	204 000	45 900	6 400	9 500
322R	110	4.3307	240	9.4488	50	1.9685	2.5	.10	1.0	.040	18 800	29.2	255 000	57 300	255 000	57 300	6 000	9 000
324R	120	4.7244	260	10.2362	55	2.1654	2.5	.10	1.0	.040	22 100	34.3	265 000	59 600	300 000	67 400	5 800	8 400
326R	130	5.1181	280	11.0236	58	2.2835	3.0	.12	1.0	.040	25 700	39.8	296 000	66 500	345 000	77 600	5 300	7 800

¹⁾ Fillet radius indicates maximum fillet radius on shaft or in housing which bearing corner will clear.

²⁾ Rating for one million revolutions or 500 hours at 33 1/3 RPM.

³⁾ Values have been determined through historical application and practice. For a more complete explanation, see pg. 274.

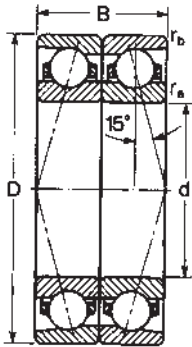

Precision 300-RD series angular contact ball bearings are manufactured to meet dimensional and running accuracy to ABEC-7 tolerances. They are supplied with an inner ring centered phenolic cage designed to minimize centrifugal force.

For recommended mounting fits refer to "Shaft and Housing Fits" in Engineering Data Section.

"D" indicates a duplex ground half pair matched with an identical half pair and is followed by an additional suffix letter to describe the type of duplex. See pages 234 and 235 for suffix description.

For equivalent load and life calculations see pages 118 and 119.

Use these values for back-to-back (DB) or face-to-face (DF) mounting arrangements.

MRC Bearing Number	Bore		Outside Diameter D		Width B		Fillet Radius ¹⁾				Basic Radial Load Rating				Speed Rating ³⁾			
											Dynamic C ²⁾		Static C ₀		Grease	Oil		
	d	mm	in	mm	in	mm	in	r _a	r _b	ZD ²	N	lbf	N	lbf	RPM	RPM		
300RD	10	.3937	35	1.3780	22	.8661	1.0	.04	.60	.024	439	.68	17 200	3 870	9 150	2 060	37 000	58 000
301RD	12	.4724	37	1.4567	24	.9449	1.0	.04	.60	.024	439	.68	17 200	3 870	9 800	2 200	35 000	54 000
302RD	15	.5906	42	1.6535	26	1.0236	1.0	.04	.60	.024	510	.79	19 900	4 470	13 200	2 970	31 000	45 000
303RD	17	.6693	47	1.8504	28	1.1024	1.0	.04	.60	.024	632	.98	24 200	5 440	16 300	3 660	30 000	42 000
304RD	20	.7874	52	2.0472	30	1.1811	1.0	.04	.60	.024	909	1.41	33 200	7 460	22 800	5 130	24 000	36 000
305RD	25	.9843	62	2.4409	34	1.3386	1.0	.04	.60	.024	1 090	1.69	37 700	8 480	30 500	6 860	20 000	31 000
306RD	30	1.1811	72	2.8346	38	1.4961	1.0	.04	.60	.024	1 480	2.30	50 700	11 400	40 000	8 990	17 000	25 000
307RD	35	1.3780	80	3.1496	42	1.6535	1.5	.06	1.0	.040	1 940	3.00	65 000	14 600	52 000	11 700	16 000	22 000
308RD	40	1.5748	90	3.5433	46	1.8110	1.5	.06	1.0	.040	2 450	3.80	79 300	17 800	67 000	15 100	14 000	20 000
309RD	45	1.7717	100	3.9370	50	1.9685	1.5	.06	1.0	.040	3 030	4.69	95 600	21 500	81 500	18 300	12 000	18 000
310RD	50	1.9685	110	4.3307	54	2.1260	2.0	.08	1.0	.040	3 990	6.19	124 000	27 900	104 000	23 400	11 000	17 000
311RD	55	2.1654	120	4.7244	58	2.2835	2.0	.08	1.0	.040	4 690	7.26	143 000	32 100	122 000	27 400	10 000	15 000
312RD	60	2.3622	130	5.1181	62	2.4409	2.0	.08	1.0	.040	5 430	8.42	165 000	37 100	143 000	32 100	9 600	14 000
313RD	65	2.5591	140	5.5118	66	2.5984	2.0	.08	1.0	.040	5 930	9.19	174 000	39 100	160 000	36 000	8 800	13 000
314RD	70	2.7559	150	5.9055	70	2.7559	2.0	.08	1.0	.040	6 770	10.5	195 000	43 800	186 000	41 800	8 000	12 000
315RD	75	2.9528	160	6.2992	74	2.9134	2.0	.08	1.0	.040	8 390	13.0	238 000	53 500	228 000	51 300	8 000	11 000
316RD	80	3.1496	170	6.6929	78	3.0709	2.0	.08	1.0	.040	9 480	14.7	260 000	58 500	260 000	58 500	7 000	10 000
317RD	85	3.3465	180	7.0866	82	3.2283	2.5	.10	1.0	.040	10 600	16.5	281 000	63 200	290 000	65 200	6 600	9 600
318RD	90	3.5433	190	7.4803	86	3.3858	2.5	.10	1.0	.040	11 800	18.3	302 000	67 900	320 000	71 900	6 200	8 800
319RD	95	3.7402	200	7.8740	90	3.5433	2.5	.10	1.0	.040	13 100	20.3	325 000	73 100	360 000	80 900	5 900	8 800
320RD	100	3.9370	215	8.4646	94	3.7008	2.5	.10	1.0	.040	14 400	22.4	345 000	77 600	400 000	89 900	5 500	8 000
321RD	105	4.1339	225	8.8583	98	3.8583	2.5	.10	1.0	.040	15 900	24.6	371 000	83 400	405 000	91 000	5 100	7 600
322RD	110	4.3307	240	9.4488	100	3.9370	2.5	.10	1.0	.040	18 800	29.2	416 000	93 500	510 000	115 000	4 800	7 200
324RD	120	4.7244	260	10.2362	110	4.3307	2.5	.10	1.0	.040	22 100	34.3	436 000	98 000	600 000	135 000	4 600	6 700
326RD	130	5.1181	280	11.0236	116	4.5669	3.0	.12	1.0	.040	25 700	39.8	475 000	107 000	695 000	156 000	4 200	6 200

¹⁾ Fillet radius indicates maximum fillet radius on shaft or in housing which bearing corner will clear.

²⁾ Rating for one million revolutions or 500 hours at 33 1/3 RPM.

³⁾ Values have been determined through historical application and practice. For a more complete explanation, see pg. 274.

General Information

Ball Bearings manufactured specifically for the woodworking industry often carry special specifications in order to meet the requirements of both high speed and accuracy. As a result of actively participating in this market for many years, MRC has designed a line of deep groove ball bearings that meet the special needs of the woodworking industry. They are high precision bearings with carefully

controlled internal characteristics, providing very good shaft rigidity and precise control of axial and radial runout.

The bearings are available with bakelite (phenolic), pressed brass, or glass reinforced polyamide cages, as illustrated below.

Recommended mounting fits are shown on pages 258 to 259 in the shaft and housing fit section.

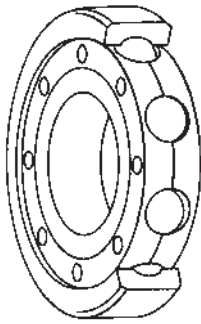

Bakelite

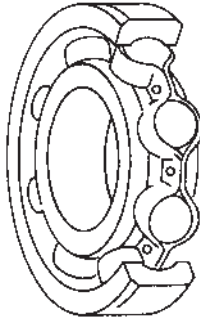

Brass

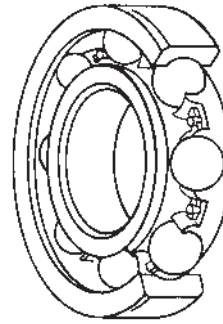

polyamide

Bearing Identification

Example of marking on MRC Bearing Box
207S-BRS#5 C2

Identification of Marking

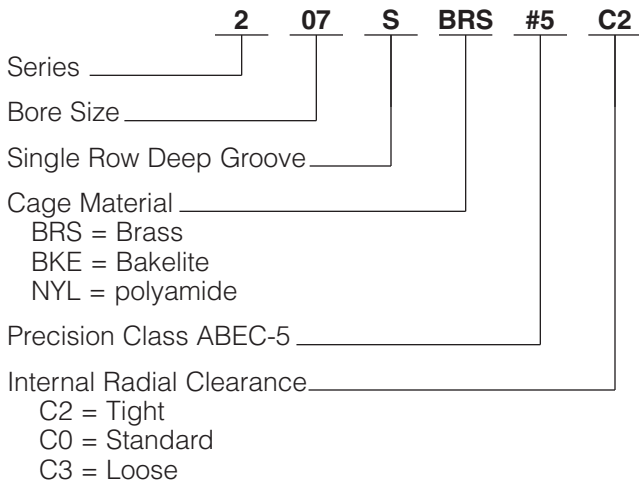

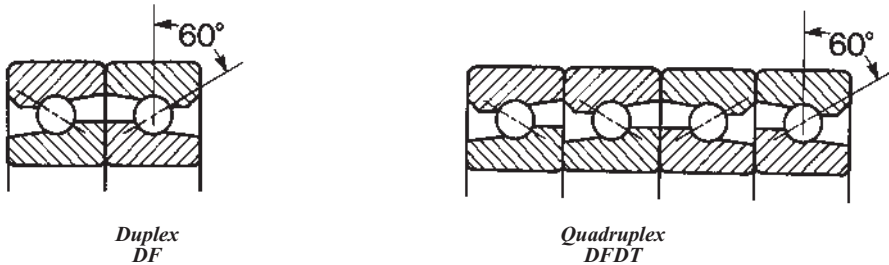

The MRC ball screw support bearing is a single-row angular contact nonseparable bearing with one heavy race shoulder and one counterbored race shoulder on the outer ring. The inner ring is similar in design having a counterbored race shoulder.

Construction and ring design permit a greater number of balls than the standard angular contact types, and result in a very high thrust load-carrying capacity. The 60° initial contact angle provides maximum axial rigidity. As heavy thrust must be taken in both directions, these angular contact bearings are mounted in duplex pairs. For even stiffer screw support, the bearings can be mounted in quadruple sets.

These bearings are made in ABEC-7 tolerance grade only. Inner and outer rings and balls are of AISI 52100 steel. Retainers are a ball-riding type of molded polyamide composition.

These ball screw support bearings are designed for use in numerically controlled machine tools where standard angular contact bearings or roller bearings cannot deliver the rigidity levels required. The 60° contact angle contributes to maximum axial rigidity and gives very stiff screw support to maintain the accuracy of the ball screw.

Cage Types and Materials

One-piece molded polyamide, ball-riding cages are supplied with ball screw support bearings.

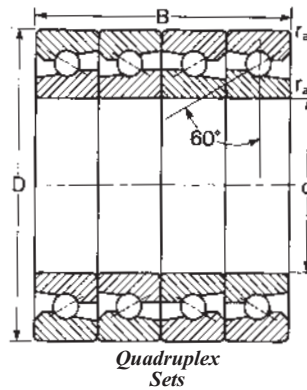
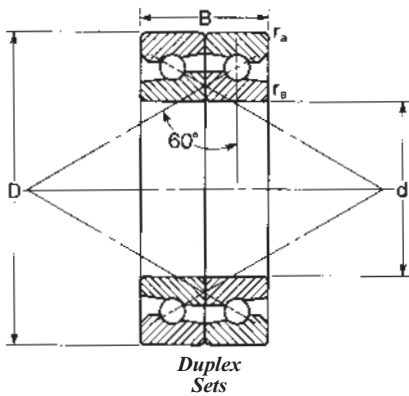

MRC Bearing Number	Bore		Outside Diameter D		Width B		Fillet Radius ¹⁾ r _a		Lateral Eccentricity Max		Basic Radial Load Rating ²⁾			
	d										Dynamic C ³⁾		Static C ₀	
	mm	in	mm	in	mm	in	mm	in	mm	in	N	lbf	N	lbf
J078DF	20.000	.7874	47.000	1.8504	31.750	1.2500	.80	.031	.003	.0001	12 100	2 720	10 000	2 250
J093DF	23.838	.9385	62.000	2.4409	31.750	1.2500	.80	.031	.003	.0001	13 800	3 100	13 700	3 080
J098DF	25.000	.9843	62.000	2.4409	31.750	1.2500	.80	.031	.003	.0001	13 800	3 100	13 700	3 080
J150DF	38.100	1.5000	72.000	2.8346	31.750	1.2500	.80	.031	.003	.0001	14 600	3 280	15 300	3 440
J175DF	44.475	1.7510	76.200	3.0000	31.750	1.2500	.80	.031	.003	.0001	15 100	3 390	16 600	3 730
J225DF	57.150	2.2500	90.000	3.5433	31.750	1.2500	.80	.031	.003	.0001	16 300	3 660	20 000	4 500
J300DF	76.200	3.0000	110.000	4.3307	31.750	1.2500	.80	.031	.003	.0001	17 800	4 000	25 500	5 730
J400DF	101.600	4.0000	145.000	5.7087	44.450	1.7500	1.0	.040	.003	.0001	36 400	8 180	52 000	11 700
Quadruplex Sets														
J078DFDT	20.000	.7874	47.000	1.8504	63.500	2.5000	.80	.031	.003	.0001	19 500	4 380	20 000	4 500
J093DFDT	23.838	.9385	62.000	2.4409	63.500	2.5000	.80	.031	.003	.0001	22 500	5 060	26 500	5 960
J098DFDT	25.000	.9843	62.000	2.4409	63.500	2.5000	.80	.031	.003	.0001	22 500	5 060	26 500	5 960
J150DFDT	38.100	1.5000	72.000	2.8346	63.500	2.5000	.80	.031	.003	.0001	23 800	5 350	30 500	6 860
J175DFDT	44.475	1.7510	76.200	3.0000	63.500	2.5000	.80	.031	.003	.0001	24 700	5 550	33 500	7 530
J225DFDT	57.150	2.2500	90.000	3.5433	63.500	2.5000	.80	.031	.003	.0001	26 500	5 960	40 000	8 990
J300DFDT	76.200	3.0000	110.000	4.3307	63.500	2.5000	.80	.031	.003	.0001	29 100	6 540	51 000	11 500
J400DFDT	101.600	4.0000	145.000	5.7087	88.900	3.5000	1.0	.040	.003	.0001	59 200	13 300	104 000	23 400

¹⁾ Fillet radius indicates maximum fillet radius on shaft or in housing which bearing corner will clear.

²⁾ For thrust rating multiply C by 1.70 and C₀ by 4.00.

³⁾ Rating for one million revolutions or 500 hours at 33 1/3 RPM.

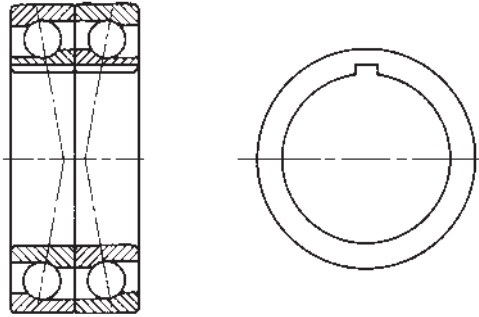

Each MRC bearing made for Ex-Cell-O®, spindles is a separable inner ring type with counterbored outer ring, with the cage and ball assembly remaining together as a unit. The bearings are manufactured to a basic ABEC-7 grade with a minus tolerance on the nominal bore and O.D. The cage, which is outer ring land-guided, has a chamfer on the bore to provide for improved flow of lubricant.

These bearings are packed in pairs, with one bearing of the pair marked with a single burnished dot on both inner and outer ring faces. The other bearing is marked with two burnished dots on both the inner and outer rings. These dots help avoid mixing of the separable bearing parts and also indicate high points of eccentricity on inner and outer rings.

Identification Markings

Ball bearings furnished for replacement use are identical to those provided for Ex-Cell-O OEM use except for identification markings. The small table below shows typical markings on inner and outer rings of MRC replacement bearings and Ex-Cell-O bearings.

	MRC Replacement Bearings	Ex-Cell-O OEM Bearings
Inner Ring	MRC USA D	MRC USA D
Outer Ring	XO-30-RBDS-16	XLO-30-57

Note that both the OEM and replacement bearings have the same marking on the inner ring—MRC USA D. However, on the outer ring of the OEM bearings, a typical marking shows XLO-30-57: XLO is the Ex-Cell-O trademark, 30 indicates the basic bearing size, 57 denotes preload group 5 (not preload in pounds) and tolerance grade ABEC-7. MRC replacement bearings are marked XO-30-RBDS-16 on the outer ring: XO designates Ex-Cell-O bearings, 30 shows the basic bearing number, RBDS indicates duplex bearings with a preload of 16 pounds.

Shaft and House Fitting Practices

Basic dimensions of this new Ex-Cell-O bearing series remain the same as bearings previously furnished. The only external dimensional differences are in the bore and O.D. tolerances, and these must be considered when replacing the old series bearings. Current fitting practices in Ex-Cell-O spindles are 0.0001" tight to 0.0001" loose on the shaft, 0.0003" loose to 0.0005" loose in the floating end of the housing and 0.0001" loose to 0.0003" loose in the held end of the housing. Therefore, it may be necessary to alter shaft and housing seat diameters to retain correct fitting practices.

How To Order

The dimension table on the next two pages provides all MRC replacement bearing numbers and corresponding Ex-Cell-O part numbers. When ordering, specify MRC bearing number, operating speed or preload, or both to assure delivery of proper bearing for application.

Difference Between Old and New Types

Basic external dimensions are the same with only a change in tolerance of the bore and O.D. in the new type. The new ball cage provides a chamfer on the bore for better flow of lubricant. One shoulder of the inner ring is low enough to permit separation from the outer ring, ball and cage assembly.

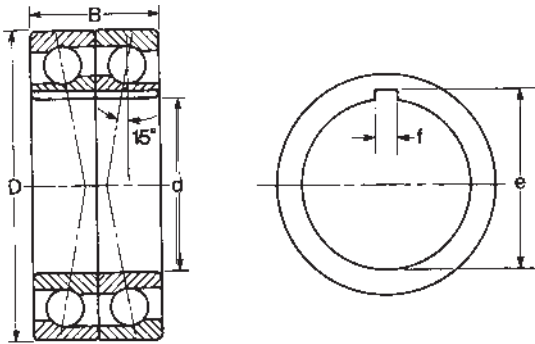

MRC Replacement Bearing Number	X-L-O Part Number	Bore		Outside Diameter D		Width B		Keyway			
		d mm	in	mm	in	mm	in	e mm	in	f mm	in
XO-20-RBDS	20-27 20-107	9.53	.37500	28.58	1.1250	17.46	.6875	9.9	.3906	1.6	.0625
XO-30-RBDS	30-17 30-27 30-57 30-77 30-107	15.88	.62500	38.10	1.5000	25.4	1.000	16.4	.645	1.6	.0625
XO-55-RBDS	55-17 55-27 55-57 55-87 55-107	20.64	.81250	50.80	2.0000	25.4	1.000	21.4	.844	1.6	.063
XO-57-RBDS	57-17 57-27 57-57 57-87 57-107	26.99	1.06250	57.15	2.2500	25.4	1.000	27.5	1.082	1.6	.063
XO-67-RBDS	67-17 67-37 67-57 67-87 67-107	31.75	1.2500	61.91	2.4375	31.75	1.250	32.6	1.285	3.2	.125
XO-90-RBDS	90-17 90-47 90-57 90-67 90-77 90-107	41.28	1.6250	87.31	3.4375	41.28	1.625	42.2	1.660	3.2	.125
XO-115-RBDS	115-17 115-27 115-37 115-47 115-57 115-77	57.15	2.2500	120.7	4.7500	57.15	2.250	58.4	2.300	4.7	.187
XO-135-RBDS	135-27 135-47 135-67 135-77 135-107	31.75	1.2500	68.26	2.6875	31.75	1.250	32.6	1.285	3.2	.125
XO-155-RBDS	155-07 155-17 155-37 155-47 155-67 155-87 155-107	69.85	2.7500	120.7	4.7500	57.15	2.250	70.9	2.790	4.7	.187
XO-165-RBDS	165-17 165-27 165-47 165-57 165-67 165-87	88.903	3.50000	160.3	6.3125	76.2	3.000	89.5	3.525	6.4	.250

MRC Replacement Bearing Number	Fillet Radius ¹⁾		Pre-Load Lbs.	Maximum Speed (RPM)		
	r_a mm	in		Grease Lub.	Oil Lub.	Mist Lub.
XO-20-RBDS	.6	.025	10	35 000	45 000	60 000
			0	40 000	65 000	80 000
XO-30-RBDS	1.0	.040	40	6 000	9 000	12 000
			30	10 000	12 500	18 000
			16	27 000	30 000	35 000
			10	30 000	35 000	45 000
			0	35 000	40 000	60 000
XO-55-RBDS	1.0	.040	80	2 000	4 000	6 000
			50	5 000	8 000	12 000
			30	20 000	22 000	24 000
			10	22 000	24 000	32 000
			0	24 000	27 000	45 000
XO-57-RBDS	1.0	.040	90	2 000	4 000	6 000
			50	5 000	8 000	12 000
			15	20 000	22 000	24 000
			10	22 000	24 000	32 000
			0	24 000	27 000	45 000
XO-67-RBDS	1.0	.040	92	3 600	4 500	6 000
			60	6 000	8 000	12 000
			20	12 500	15 000	22 000
			10	14 000	18 000	28 000
			0	16 000	20 000	35 000
XO-90-RBDS	1.5	.060	325	1 000	2 000	4 000
			180	3 000	5 000	8 000
			120	5 000	7 000	11 000
			72	8 000	10 000	14 000
			40	10 000	14 000	20 000
			0	12 000	16 000	22 000
XO-115-RBDS	2.0	.080	450	750	1 500	2 250
			350	1 000	2 000	3 000
			200	2 200	3 500	6 000
			150	3 000	4 500	7 000
			100	4 000	5 000	8 000
			30	6 000	8 000	15 000
XO-135-RBDS	1.0	.040	175	1 000	2 000	4 000
			90	3 600	4 500	6 000
			60	6 000	7 500	12 000
			25	10 000	12 000	18 000
			0	15 000	19 000	28 000
XO-155-RBDS	2.0	.080	1 000	250	250	250
			450	500	1 000	1 500
			325	1 000	2 000	3 000
			250	2 500	3 500	5 000
			150	4 000	5 000	6 500
			60	6 000	7 000	10 000
			0	7 000	9 000	12 000
XO-165-RBDS	2.0	.080	1200	500	800	1 200
			800	500	1 000	2 000
			400	1 000	2 000	4 000
			250	2 000	3 000	5 000
			175	3 000	4 000	6 000
			50	5 000	6 500	9 000

¹⁾ Fillet radius indicates maximum fillet radius on shaft or in housing which bearing corner will clear.