

Marine applications

Products and solutions based on
the SKF oil injection method



Increase days at sea



SKF Coupling Systems help the marine industry worldwide to set the course for improved maintenance with shorter docking times and better total profitability.

Mounting and dismounting of heavy marine components are simplified by the SKF oil injection method. Precision products like OK shaft and flange couplings, Supergrip bolts and marine hydraulic nuts are based on this technology reducing operations that took hours or even days to a few, rapidly performed steps.

Over the life of a ship, the savings from the SKF oil injection method are quite substantial in terms of reduced docking time and related costs.

Designed for high torques

The SKF oil injection method offers innovative solutions for connecting qualified applications such as propeller shafts, propellers and rudder assemblies. High torques are transmitted by applying a powerful interference fit. Machining of shafts and other components can thus be simplified and strength increased.

SKF technology, quality and service

Since we developed the oil injection method, we have carried the technology even further. Today, we continue to improve marine products saving time and money for carriers around the world. Thanks to SKF's global sales and service network, you can always find us in your local market.

A winner at sea

The right product and the right competence is a winning combination also at sea. SKF Coupling Systems supports you by hightech products from a global network, local service and backup, training and secure deliveries.

SKF OK shaft and flange couplings cut down on docking time

The SKF oil injection method presents benefits impossible to achieve with traditional couplings. The simplicity of mounting and dismounting and the high torque transmission capacity reduces docking time and improve reliability at sea.

Operation	Time required SKF OK coupling
Mounting of coupling	approx. 1 hour
Dismounting of coupling	approx. 1 hour

Reliable oil injection method

SKF Coupling Systems has been a partner to the marine industry since the 1940s when the oil injection method was invented by us. Since then, more than 35 000 couplings have been supplied for demanding applications in ships and power installations etc, all over the world.

SKF has played an important role in continually reducing time and costs for shipyards through good products, technical support and knowledge.

As a player with a global marine network, SKF works as a long-term supplier of products, techniques and service to help marine customers to improve their economical performance and competitiveness.

Get expertise – not just a product

SKF can offer you detailed analyses and advice on any aspect of your propulsion design work. Teamwork alongside SKF Coupling Systems will help you identify and implement the latest oil injection method.



One of the very first ships that was equipped with OK shaft couplings was the M/S Salaminia. That was in 1945.

Since then we have equipped all types of vessels with products based on the SKF oil injection method providing opportunities to improve operational time at sea.



Fully marine approved

Our precision-made products and systems are installed in a wide range of marine vessels all over the world. The products are approved for use by all leading international and national classification societies and regulatory bodies.

Marine hydraulic nut

The SKF oil injection method is an outstanding alternative for mounting and dismounting propellers. It enables the driving of a 50-ton propeller up the shaft in twenty minutes and to dismount the propeller in ten minutes. The propeller is hydraulically pressed onto tapered seating by a hydraulic ring or nut.

The method is fully accepted by the world's leading classification societies. This is also the preferred method for mounting components like rudder pintles and tillers when short service time is a requirement.





OK shaft and flange couplings

When using the OK coupling in shaft connections, you exploit potent oil injection technology. Preparation of the shaft is simple. No keyways to machine, no taper and no thrust rings. Ease of mounting and dismounting combined with high torque capacity are characteristics of the SKF OK couplings.



Supergrip bolts

Supergrip bolts are a superior solution for connecting flange couplings. Compared with traditional bolt systems, Supergrip bolts are much faster and easier to install and remove, take much less time, while fastening the coupling halves much more securely together.

Supergrip bolts are designed specifically for such high-torque applications as propeller shafts and rudder assemblies. Using Supergrip eliminates uncertainty about the length of downtime for removing and installing the bolts.

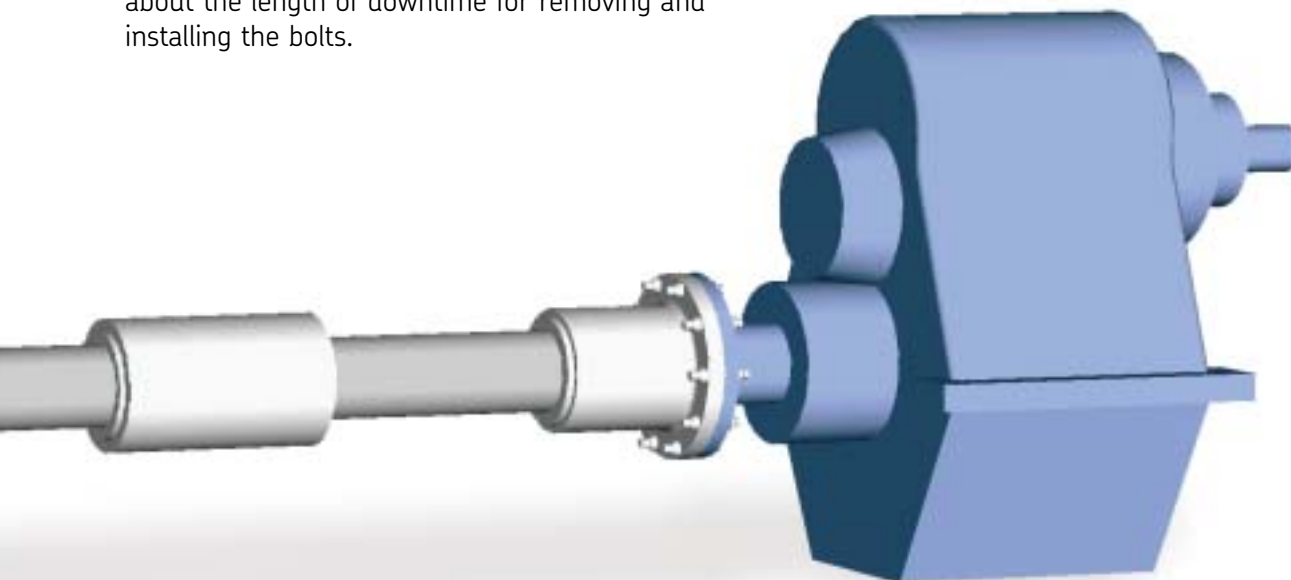

SKF Coupling Systems AB was established in the early 1940s when SKF's Chief Designer, Erland Bratt, invented the SKF oil injection method. As the result of continuous development, SKF is currently a world leader in selected market niches.

Our business concept is to develop, produce and supply products based on the SKF oil injection method. These products significantly reduce downtime and lower maintenance costs of the capital-intensive equipment in which they are used.



SKF Coupling Systems AB

SE-813 82 Hofors, Sweden.
Tel: +46 290 284 00. Fax: +46 290 282 70
E-mail: skf.coupling.systems@skf.com
Website: www.couplings.skf.com

