

Maximizing bearing performance

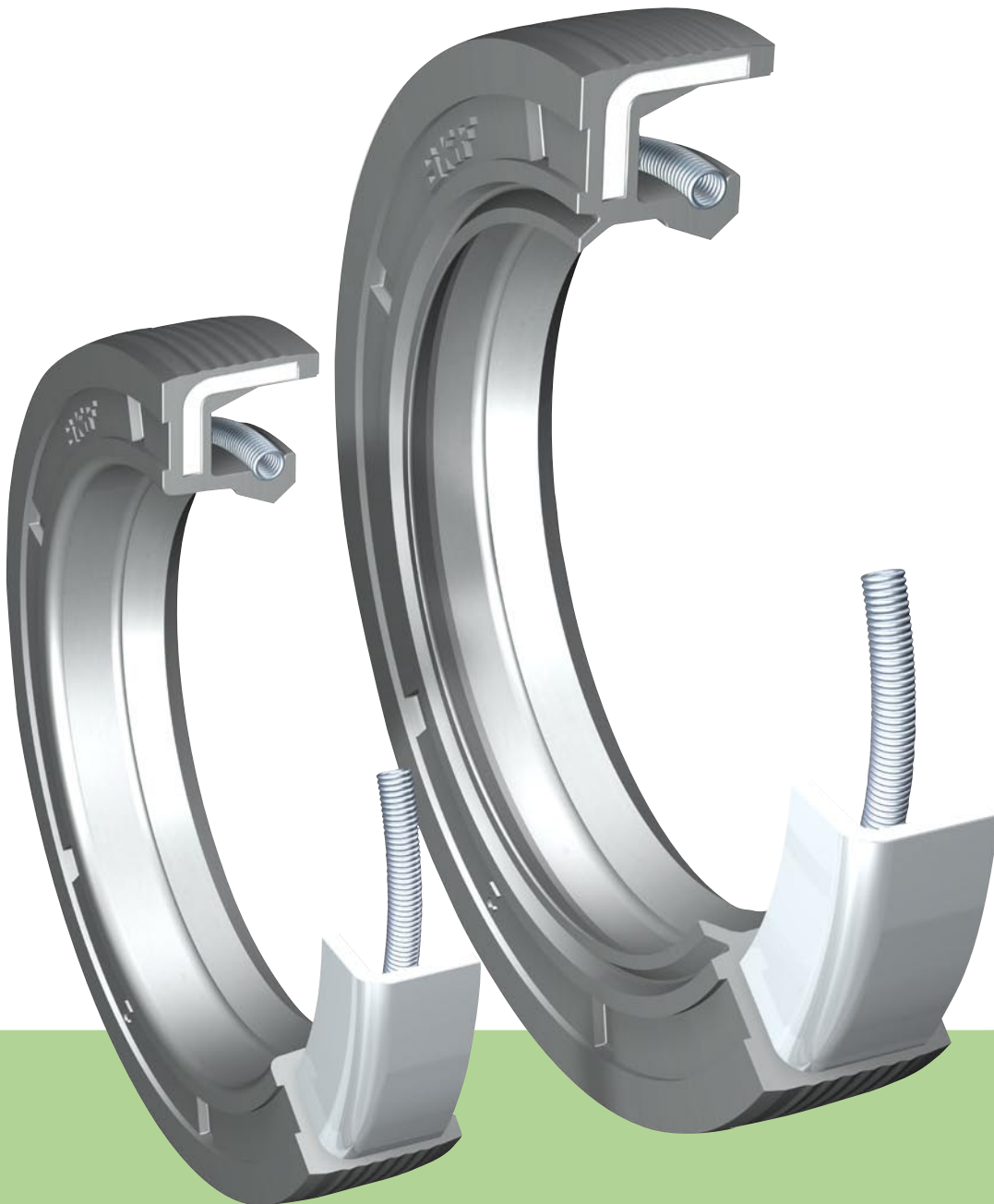

Radial shaft seals HMS5 and HMSA10

- Longer service life
- Improved sealing performance
- Excellent oil compatibility



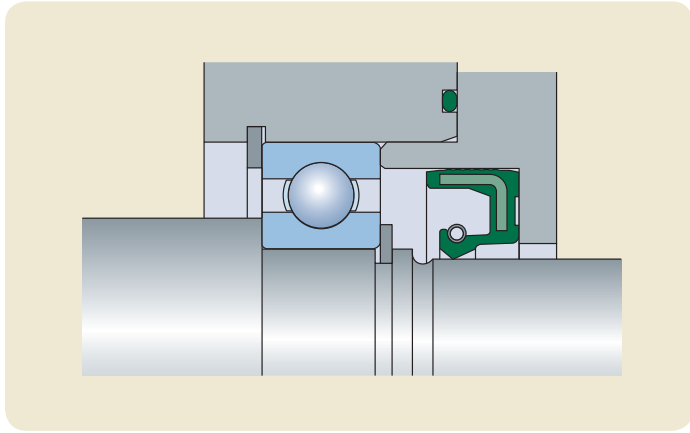

Installation example

Radial shaft seals

HMS5 and HMSA10

Main features

The new metric line of rubber outside diameter radial shaft seals, HMS5 and HMSA10, is designed in accordance with ISO 6194 and DIN 3760 for use in a wide range of industrial applications. The available size range of HMS5 and HMSA10 includes a full coverage of the ISO 6194 and DIN 3760 dimensions up to 250 mm shaft sizes. Main features are

- New optimized seal material
- Spring-loaded sealing lip
- Balanced sealing lip and flex section
- Beaded outside diameter
- Auxiliary lip (type HMSA10 only)

Design

The rubber outside diameter provides optimized sealing ability in the housing, also at considerable surface roughness or a split housing.

The spring-loaded sealing lip contributes to a quick response to handle dynamic run-out and to maintain the sealing ability also at excessive wear.

The sealing lip and flex section are balanced to achieve good followability to withstand considerable dynamic runout and shaft-to-bore misalignment.

The beads on the outside diameter provide an improved sealing ability and a reliable

retention in the bore. It also prevents spring back at assembly.

The auxiliary lip of type HMSA10 is non-contacting, which means that the seal type normally can be used at the same speeds as the single-lip type HMS5, without significantly increased torque and underlip temperature.

Material

Metal insert:

Mild steel

Spring:

Spring steel

Sealing lips and outside diameter:

Acrylonitrile-butadiene rubber, hardness 75° Shore A, material code SKF NBR 3243.

The compound has the designation suffix RG.

The new nitrile rubber compound is the result of developments in seal material research at SKF. Advantages of this material include

- Good resistance to ageing
- Excellent compatibility to synthetic oils
- Very good pumping ability
- Good wear resistance

Pumping ability is defined as the time it takes for the seal to return a certain amount of oil from the air side to the oil side. The shorter the time the more effective the seal. The microstructure of the SKF NBR 3243 com-

pound results in that the seal will rapidly pump back the oil.

Table 1 and **diagram 1** show the differences between the formerly used standard material and the new compound for HMS5 RG and HMSA10 RG when it comes to secure proper sealing and a long service life.

The complete range of HMS5 and HMSA10 seals is also available on request in a fluoro rubber compound with the garter spring in stainless steel. This compound has the designation suffix V and is used in applications with temperatures beyond the limits of nitrile rubber.

Applications and operating conditions

Series HMS5 (→ **fig. 1**) and HMSA10 (→ **fig. 2**) are designed for optimum use in applications lubricated with oil or grease in temperatures ranging from -40 to +100 °C (-40 to 212 °F), short-term up to 120 °C (248 °F). The series are also appropriate for sealing lubricants within a wide range of viscosities.

Surface speed:

up to 14 m/s (2 755 ft./min.)

Operating pressure:

max 0,03 MPa (5 psi)

These values are the maximum value for each service condition and should not occur together. Consideration must be taken to how the service conditions affect each other.

Machining directions

Recommendations according to ISO 6194 standard

Shaft

Tolerance:

h11

Surface roughness:

R_a 0,2 to 0,5 μm

R_z 1,2 to 3 μm

Hardness:

minimum 45 HRC

Surface texture:

non-oriented, preferably by plunge grinding

Housing bore

Tolerance:

H8

Diagram 1

Average seal life
(as a percentage of baseline, product A)

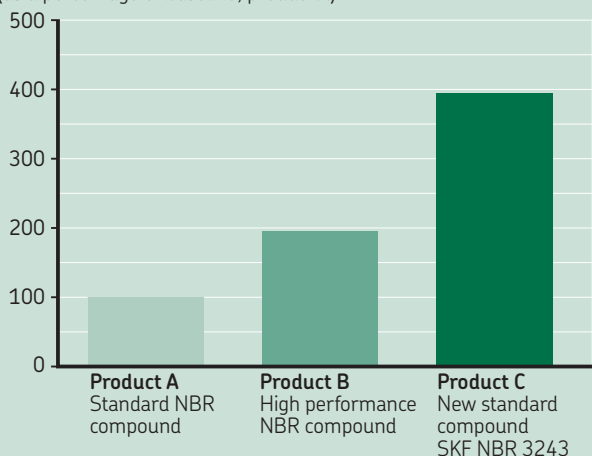

Endurance test

Table 1

Speed rotating	linear	Pumping time	
		Standard NBR	SKF NBR 3243
rpm	m/s	s	
1 000	3,0	–	117
1 500	4,6	280	69
2 000	6,1	186	50
2 500	7,6	130	40
3 000	9,1	102	31
3 500	10,6	82	25
4 000	12,1	68	21
4 500	13,7	57	18

Shaft diameter 60 mm, engine oil SAE 30

Pumping performance

Surface roughness:

R_a 1,6 to 3,2 µm
R_z 6,3 to 12,5 µm

Recommendations according to DIN 3760 standard

Shaft

Tolerance:

h11

Surface roughness:

R_a 0,2 to 0,8 µm
R_z 1 to 5 µm

Hardness:

minimum 45 HRC

Surface texture:

non-oriented, preferably by plunge grinding

Housing bore

Tolerance:

H8

Surface roughness:

R_a 1,6 to 6,3 µm
R_z 10 to 20 µm

Installation

Careful fitting according to ISO 6194 or DIN 3760 is a prerequisite for proper functioning of the seal.

For further details about mounting of SKF radial shaft seals, please see our catalogue "Industrial shaft seals" (6008) or visit the SKF Interactive Engineering Catalogue at skf.com.

We recommend to use seals of type HMSA10 with a secondary lip in applications with increased demand on protection of the primary lip.

For more information, please contact your local SKF sales representative.

HMS5 RG

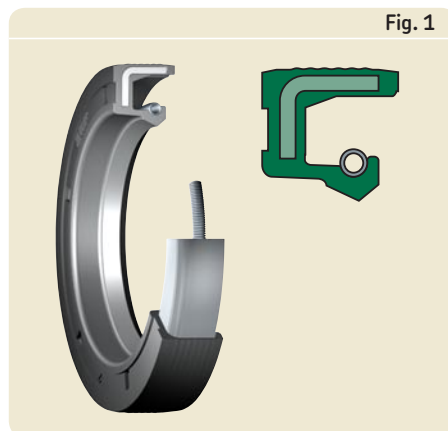

HMSA10 RG

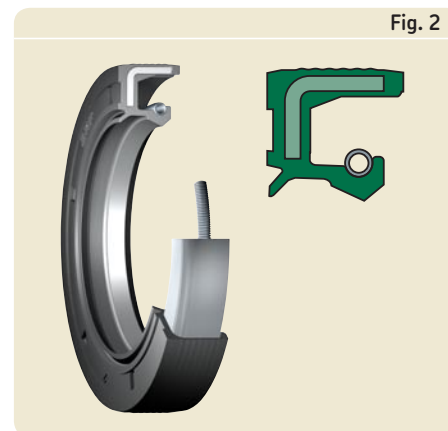

Radial shaft seals HMS5 and HMSA10

d_1 6 – 27 mm

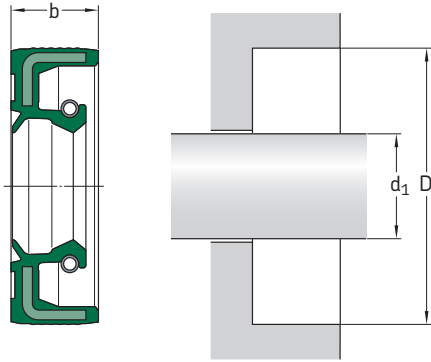

Dimensions				Designation	ISO/DIN	Dimensions				
shaft	bore	nominal seal width				shaft	bore	nominal seal width		
d_1	D	b			d_1	D	b			
mm			–	–	mm			–		
6	16	5	CR 6×16×5*		12	30	7	CR 12×30×7*	•	
	16	7	CR 6×16×7*	•		32	7	CR 12×32×7*		
	22	7	CR 6×22×7*	•		13	26	7	CR 13×26×7*	
7	16	7	CR 7×16×7**		14		24	7	CR 14×24×7*	•
	22	7	CR 7×22×7*	•		25	5	CR 14×25×5*		
8	18	5	CR 8×18×5*		15	28	7	CR 14×28×7*		
	18	7	CR 8×18×7*			30	7	CR 14×30×7*	•	
	22	7	CR 8×22×7*	•		15	24	7	CR 15×24×7**	
9	24	7	CR 8×24×7*	•	25		5	CR 15×25×5*		
	22	7	CR 9×22×7*	•	25	6	CR 15×25×6*			
10	19	7	CR 10×19×7**		16	26	7	CR 15×26×7*	•	
	20	6	CR 10×20×6*			30	7	CR 15×30×7*	•	
		7	CR 10×20×7*				32	7	CR 15×32×7*	
	22	7	CR 10×22×7*	•		35		7	CR 15×35×7*	•
	24	7	CR 10×24×7*				40	10	CR 15×40×10*	
	25	7	CR 10×25×7*	•		16		28	7	CR 16×28×7*
	26	7	CR 10×26×7*	•			30	7	CR 16×30×7*	•
12	19	5	CR 12×19×5**		16	32	7	CR 16×32×7*		
	22	5	CR 12×22×5*			35	7	CR 16×35×7*	•	
		6	CR 12×22×6*				24	7	CR 12×24×7*	•
		7	CR 12×22×7*	•				25	7	CR 12×25×7*
	24	7	CR 12×24×7*	•		28	7		CR 12×28×7*	
	25	7	CR 12×25×7*	•						

* To be followed by the design and material codes, indicating one of the four variants available for each dimension:

HMS5 RG without secondary lip, nitrile rubber

HMS5 V without secondary lip, fluoro rubber

HMSA10 RG with secondary lip, nitrile rubber

HMSA10 V with secondary lip, fluoro rubber

Example: **CR 6×16×5 HMSA10 RG**

** Design execution differs from the basic design and is indicated by a number, e.g. RG1

Dimensions				Designation	ISO/DIN	Dimensions			
shaft	bore	nominal seal width				shaft	bore	nominal seal width	
d ₁	D	b			d ₁	D	b		
mm				–	–	mm			
17	28	7	CR 17×28×7*		22	42	10	CR 22×42×10*	
	29	5	CR 17×29×5*			47	7	CR 22×47×7*	•
	30	7	CR 17×30×7*		23	40	10	CR 23×40×10*	
	32	7	CR 17×32×7*			24	35	7	CR 24×35×7*
	35	7	CR 17×35×7*		37		7	CR 24×37×7*	
	40	7	CR 17×40×7*		40	7	CR 24×40×7*		
18	40	10	CR 17×40×10*		42	8	CR 24×42×8*		
	28	7	CR 18×28×7*		47	7	CR 24×47×7*		
	30	6	CR 18×30×6*		25	35	6	CR 25×35×6*	
	30	7	CR 18×30×7*	•		35	7	CR 25×35×7*	•
	32	7	CR 18×32×7*		37	5	CR 25×37×5*		
	35	7	CR 18×35×7*	•	37	6	CR 25×37×6*		
40	7	CR 18×40×7*		37	7	CR 25×37×7*			
19	30	7	CR 19×30×7*		38	7	CR 25×38×7*		
	30	8	CR 19×30×8*		40	5	CR 25×40×5*		
	32	7	CR 19×32×7*		40	7	CR 25×40×7*	•	
	32	7	CR 19×32×7*		40	8	CR 25×40×8*		
20	30	5	CR 20×30×5*		40	10	CR 25×40×10*		
	30	7	CR 20×30×7*	•	42	6	CR 25×42×6*		
	32	7	CR 20×32×7*		42	7	CR 25×42×7*		
	34	7	CR 20×34×7*		42	10	CR 25×42×10*		
	35	6	CR 20×35×6*		45	7	CR 25×45×7*		
	35	7	CR 20×35×7*	•	45	8	CR 25×45×8*		
	35	8	CR 20×35×8*		45	10	CR 25×45×10*		
	35	10	CR 20×35×10*		46	7	CR 25×46×7*		
	36	7	CR 20×36×7*		47	7	CR 25×47×7*	•	
	38	7	CR 20×38×7*		47	10	CR 25×47×10*		
	40	7	CR 20×40×7*	•	50	10	CR 25×50×10*		
	40	10	CR 20×40×10*		52	7	CR 25×52×7*	•	
21	42	7	CR 20×42×7*		52	8	CR 25×52×8*		
	42	10	CR 20×42×10*		52	10	CR 25×52×10*		
	47	7	CR 20×47×7*		62	7	CR 25×62×7*		
	47	10	CR 20×47×10*		62	8	CR 25×62×8*		
	52	7	CR 20×52×7*		62	10	CR 25×62×10*		
	52	10	CR 20×52×10*		26	37	7	CR 26×37×7*	
	35	7	CR 21×35×7*			38	5	CR 26×38×5*	
	22	32	7	CR 22×32×7*		38	7	CR 26×38×7*	
		35	7	CR 22×35×7*	•	42	7	CR 26×42×7*	
		36	7	CR 22×36×7*		47	7	CR 26×47×7*	
38		8	CR 22×38×8*		27	37	7	CR 27×37×7*	
40		7	CR 22×40×7*	•		42	10	CR 27×42×10*	
40		10	CR 22×40×10*		43	7	CR 27×43×7*		
23	40	10	CR 22×40×10*		47	10	CR 27×47×10*		

Radial shaft seals HMS5 and HMSA10

d₁ 28 – 43 mm

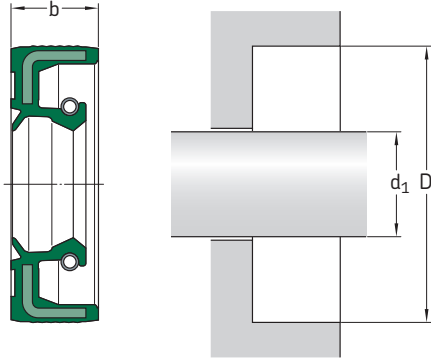

Dimensions				Designation	ISO/DIN	Dimensions					
shaft	bore	nominal seal width				shaft	bore	nominal seal width			
d ₁	D	b			d ₁	D	b				
mm			–	–	mm			–			
28	38	7	CR 28×38×7*		30	52	7	CR 30×52×7*	•		
	38	8	CR 28×38×8*			52	8	CR 30×52×8*			
	40	7	CR 28×40×7*	•		52	10	CR 30×52×10*			
	40	8	CR 28×40×8*			55	7	CR 30×55×7*			
	42	7	CR 28×42×7*			55	10	CR 30×55×10*			
	42	8	CR 28×42×8*			62	7	CR 30×62×7*			
	44	6	CR 28×44×6*			62	10	CR 30×62×10*			
	45	8	CR 28×45×8*			72	10	CR 30×72×10*			
	47	7	CR 28×47×7*	•		32	42	7	CR 32×42×7*		
	47	10	CR 28×47×10*				43	7	CR 32×43×7*		
	52	7	CR 28×52×7*	•			44	7	CR 32×44×7*		
	52	10	CR 28×52×10*				45	7	CR 32×45×7*	•	
	30	40	7	CR 30×40×7*			•	45	8	CR 32×45×8*	•
		42	6	CR 30×42×6*				47	6	CR 32×47×6*	
42		7	CR 30×42×7*	•	47		7	CR 32×47×7*	•		
42		8	CR 30×42×8*		47		8	CR 32×47×8*	•		
44		7	CR 30×44×7*		47		10	CR 32×47×10*			
45		7	CR 30×45×7*		48		8	CR 32×48×8*			
45		8	CR 30×45×8*		50	8	CR 32×50×8*				
46		7	CR 30×46×7*		50	10	CR 32×50×10*				
47		6	CR 30×47×6*		52	7	CR 32×52×7*	•			
47		7	CR 30×47×7*	•	52	8	CR 32×52×8*	•			
47		8	CR 30×47×8*		55	10	CR 32×55×10*				
47		10	CR 30×47×10*		62	10	CR 32×62×10*				
48		8	CR 30×48×8*		72	7	CR 32×72×7*				
50		7	CR 30×50×7*		33	45	7	CR 33×45×7*			
50	8	CR 30×50×8*		50		6	CR 33×50×6*				
50	10	CR 30×50×10*									

* To be followed by the design and material codes, indicating one of the four variants available for each dimension:

HMS5 RG without secondary lip, nitrile rubber

MS5 V without secondary lip, fluoro rubber

HMSA10 RG with secondary lip, nitrile rubber

HMSA10 V with secondary lip, fluoro rubber

Example: CR 28×38×7 HMSA10 RG

Dimensions			Designation	ISO/DIN	Dimensions			Designation	ISO/DIN
shaft	bore	nominal seal width			shaft	bore	nominal seal width		
d ₁	D	b				b			
mm			–	–	mm		–	–	
34	44	8	CR 34x44x8*		38	60	10	CR 38x60x10*	
	48	8	CR 34x48x8*			62	7	CR 38x62x7*	•
	52	8	CR 34x52x8*			62	8	CR 38x62x8*	•
	62	10	CR 34x62x10*			62	10	CR 38x62x10*	
35	45	7	CR 35x45x7*		72	10	CR 38x72x10*		
	47	6	CR 35x47x6*		38,5	58	7	CR 38.5x58x7*	
	47	7	CR 35x47x7*	•		40	50	8	CR 40x50x8*
	47	8	CR 35x47x8*	•	52		6	CR 40x52x6*	
	48	8	CR 35x48x8*		52	7	CR 40x52x7*	•	
	49	6	CR 35x49x6*		52	8	CR 40x52x8*	•	
	50	7	CR 35x50x7*	•	55	7	CR 40x55x7*	•	
	50	8	CR 35x50x8*	•	55	8	CR 40x55x8*	•	
	50	10	CR 35x50x10*		56	8	CR 40x56x8*		
	52	7	CR 35x52x7*	•	58	7	CR 40x58x7*		
	52	8	CR 35x52x8*	•	58	8	CR 40x58x8*		
	52	10	CR 35x52x10*		58	10	CR 40x58x10*		
	55	7	CR 35x55x7*	•	60	10	CR 40x60x10*		
	55	8	CR 35x55x8*	•	62	6	CR 40x62x6*		
	55	10	CR 35x55x10*		62	7	CR 40x62x7*	•	
	56	10	CR 35x56x10*		62	8	CR 40x62x8*	•	
	58	10	CR 35x58x10*		62	10	CR 40x62x10*		
	60	10	CR 35x60x10*		65	10	CR 40x65x10*		
	62	7	CR 35x62x7*		65	12	CR 40x65x12*		
	62	8	CR 35x62x8*		68	8	CR 40x68x8*		
	62	10	CR 35x62x10*		68	10	CR 40x68x10*		
72	10	CR 35x72x10*		72	7	CR 40x72x7*			
72	12	CR 35x72x12*		72	10	CR 40x72x10*			
80	12	CR 35x80x12*		80	10	CR 40x80x10*			
36	47	7	CR 36x47x7*		80	12	CR 40x80x12*		
	50	7	CR 36x50x7*		41	56	7	CR 41x56x7*	
	52	7	CR 36x52x7*			42	55	7	CR 42x55x7*
	58	10	CR 36x58x10*		55		8	CR 42x55x8*	•
	62	7	CR 36x62x7*		56		7	CR 42x56x7*	
37	50	6	CR 37x50x6*		60	7	CR 42x60x7*		
	50	7	CR 38x50x7*		62	7	CR 42x62x7*		
	52	8	CR 38x52x8*		62	8	CR 42x62x8*	•	
38	52	10	CR 38x54x10*		62	10	CR 42x62x10*		
	55	7	CR 38x55x7*	•	65	10	CR 42x65x10*		
	55	8	CR 38x55x8*	•	65	12	CR 42x65x12*		
	55	10	CR 38x55x10*		66	10	CR 42x66x10*		
	58	8	CR 38x58x8*	•	67	10	CR 42x67x10*		
	58	10	CR 38x58x10*		72	8	CR 42x72x8*		
					72	10	CR 42x72x10*		
					43	62	8	CR 43x62x8*	

Radial shaft seals HMS5 and HMSA10

d₁ 44 – 85 mm

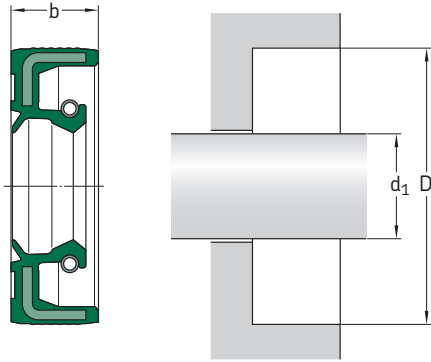

Dimensions				Designation	ISO/DIN	Dimensions			
shaft	bore	nominal seal width				shaft	bore	nominal seal width	
d ₁	D	b			d ₁	D	b		
mm			–	–	mm			–	
44	60	10	CR 44×60×10*		48	62	8	CR 48×62×8*	•
	62	10	CR 44×62×10*			65	10	CR 48×65×10*	
	65	10	CR 44×65×10*			68	10	CR 48×68×10*	
45	55	7	CR 45×55×7*		70	10	CR 48×70×10*		
	58	7	CR 45×58×7*		72	7	CR 48×72×7*		
	60	7	CR 45×60×7*		72	8	CR 48×72×8*		
	60	8	CR 45×60×8*	•	72	10	CR 48×72×10*		
	60	10	CR 45×60×10*		50	62	7	CR 50×62×7*	
	62	7	CR 45×62×7*		64	6	CR 50×64×6*		
	62	8	CR 45×62×8*	•	65	8	CR 50×65×8*	•	
	62	10	CR 45×62×10*		65	10	CR 50×65×10*	•	
	65	8	CR 45×65×8*	•	68	7	CR 50×68×7*		
	65	10	CR 45×65×10*		68	8	CR 50×68×8*	•	
	68	7	CR 45×68×7*		68	10	CR 50×68×10*	•	
	68	10	CR 45×68×10*		70	10	CR 50×70×10*		
	68	12	CR 45×68×12*						
	72	8	CR 45×72×8*		72	8	CR 50×72×8*	•	
	72	10	CR 45×72×10*		72	10	CR 50×72×10*		
				72	12	CR 50×72×12*			
	75	8	CR 45×75×8*		75	10	CR 50×75×10*		
	75	10	CR 45×75×10*						
	80	10	CR 45×80×10*		80	8	CR 50×80×8*		
					80	10	CR 50×80×10*		
	85	10	CR 45×85×10*		85	10	CR 50×85×10*		
46	59	12	CR 46×59×12*		90	10	CR 50×90×10*		
	65	10	CR 46×65×10*						
47	65	10	CR 47×65×10*		52	63	8	CR 52×63×8*	
	70	10	CR 47×70×10*		65	8	CR 52×65×8*		

* To be followed by the design and material codes, indicating one of the four variants available for each dimension:

HMS5 RG without secondary lip, nitrile rubber

HMS5 V without secondary lip, fluoro rubber

HMSA10 RG with secondary lip, nitrile rubber

HMSA10 V with secondary lip, fluoro rubber

Example: CR 44×60×10 HMSA10 RG

Dimensions			Designation	ISO/DIN	Dimensions			Designation	ISO/DIN	
shaft	bore	nominal seal width			shaft	bore	nominal seal width			
d ₁	D	b			d ₁	D	b			
mm			–	–	mm			–	–	
52	68	8	CR 52×68×8*		65	80	8	CR 65×80×8*		
	72	8	CR 52×72×8*			85	10	CR 65×85×10*	•	
	72	10	CR 52×72×10*			85	12	CR 65×85×12*		
	80	10	CR 52×80×10*			88	12	CR 65×88×12*		
	85	10	CR 52×85×10*			90	10	CR 65×90×10*	•	
55	68	8	CR 55×68×8*		95	10	CR 65×95×10*			
	70	8	CR 55×70×8*	•	100	10	CR 65×100×10*			
	70	10	CR 55×70×10*		68	90	10	CR 68×90×10*		
	72	8	CR 55×72×8*	•		70	85	8	CR 70×85×8*	
	72	10	CR 55×72×10*		90		10	CR 70×90×10*	•	
	75	10	CR 55×75×10*		90	12	CR 70×90×12*			
	78	10	CR 55×78×10*		92	12	CR 70×92×12*			
	78	12	CR 55×78×12*		95	10	CR 70×95×10*	•		
	80	8	CR 55×80×8*	•	100	10	CR 70×100×10*			
	80	10	CR 55×80×10*		110	10	CR 70×110×10*			
85	8	CR 55×85×8*		110	12	CR 70×110×12*				
85	10	CR 55×85×10*		72	90	10	CR 72×90×10*			
90	10	CR 55×90×10*			95	10	CR 72×95×10*			
100	12	CR 55×100×12*			100	10	CR 72×100×10*			
56	72	8	CR 56×72×8*		75	90	10	CR 75×90×10*		
57	67	7	CR 57×67×7*			95	10	CR 75×95×10*	•	
58	72	8	CR 58×72×8*		95	12	CR 75×95×12*			
	80	8	CR 58×80×8*		100	10	CR 75×100×10*	•		
	80	10	CR 58×80×10*		100	12	CR 75×100×12*			
80	12	CR 58×80×12*		78	105	10	CR 75×105×10*			
60	72	8	CR 60×72×8*			110	12	CR 75×110×12*		
	75	8	CR 60×75×8*		•	120	12	CR 75×120×12*		
	80	8	CR 60×80×8*		•	80	95	10	CR 80×95×10*	
	80	10	CR 60×80×10*				100	10	CR 80×100×10*	•
	80	12	CR 60×80×12*		100	12	CR 80×100×12*			
82	12	CR 60×82×12*		105	10	CR 80×105×10*				
85	8	CR 60×85×8*	•	85	100	10	CR 85×100×10*			
85	10	CR 60×85×10*			105	12	CR 85×105×12*			
90	8	CR 60×90×8*			110	12	CR 85×110×12*	•		
90	10	CR 60×90×10*		88	115	12	CR 85×115×12*			
95	10	CR 60×95×10*			120	12	CR 85×120×12*	•		
110	8	CR 60×110×8*		85	130	12	CR 85×130×12*			
62	80	10	CR 62×80×10*							
	85	10	CR 62×85×10*							
	90	10	CR 62×90×10*							
63	85	10	CR 63×85×10*							
	90	10	CR 63×90×10*							
64	80	8	CR 64×80×8*							

Radial shaft seals HMS5 and HMSA10

d₁ 90 – 250 mm

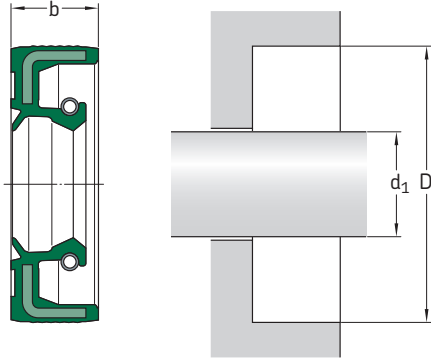

Dimensions				Designation	ISO/DIN	Dimensions				
shaft	bore	nominal seal width				shaft	bore	nominal seal width		
d ₁	D	b			d ₁	D	b			
mm			–	–	mm			–		
90	110	10	CR 90×110×10*		130	160	12	CR 130×160×12*	•	
	110	12	CR 90×110×12*	•		160	15	CR 130×160×15*	•	
	115	12	CR 90×115×12*			135	170	12	CR 135×170×12*	•
95	120	12	CR 90×120×12*	•	140	160	12	CR 140×160×12*		
	115	12	CR 95×115×12*			170	12	CR 140×170×12*	•	
	120	12	CR 95×120×12*	•		170	15	CR 140×170×15*	•	
100	125	12	CR 95×125×12*	•	145	180	12	CR 140×180×12*		
	120	10	CR 100×120×10*			175	15	CR 145×175×15*	•	
	120	12	CR 100×120×12*	•		148	170	15	CR 148×170×15*	
105	125	12	CR 100×125×12*	•	150	180	12	CR 150×180×12*		
	130	12	CR 100×130×12*	•		180	15	CR 150×180×15*	•	
	140	12	CR 100×140×12*			155	180	15	CR 155×180×15*	
110	150	12	CR 100×150×12*		160	185	15	CR 160×185×15*		
	130	12	CR 105×130×12*	•		190	15	CR 160×190×15*	•	
	140	12	CR 105×140×12*			165	190	15	CR 165×190×15*	
115	140	12	CR 110×130×12*	•	170	200	15	CR 170×200×15*	•	
	140	12	CR 110×140×12*	•		180	210	15	CR 180×210×15*	•
	150	12	CR 110×150×12*			190	220	15	CR 190×220×15*	•
120	150	12	CR 110×150×12*		190	225	15	CR 190×225×15*		
	140	12	CR 115×140×12*	•		225	15	CR 190×225×15*		
	140	12	CR 120×140×12*			200	230	15	CR 200×230×15*	•
125	150	12	CR 120×140×12*		210	240	15	CR 210×240×15*	•	
	150	12	CR 120×150×12*	•		220	250	15	CR 220×250×15*	•
	160	12	CR 120×160×12*			230	260	15	CR 230×260×15*	•
125	150	12	CR 125×150×12*	•						

* To be followed by the design and material codes, indicating one of the four variants available for each dimension:

HMS5 RG without secondary lip, nitrile rubber

HMS5 V without secondary lip, fluoro rubber

HMSA10 RG with secondary lip, nitrile rubber

HMSA10 V with secondary lip, fluoro rubber

Example: CR 90×110×10 HMSA10 RG

Dimensions			Designation	ISO/DIN
shaft	bore	nominal seal width		
d_1	D	b		
mm			–	–
240	270	15	CR 240×270×15*	•
250	280	15	CR 250×280×15*	•
	285	15	CR 250×285×15*	



© SKF is a registered trademark of the SKF Group.

© SKF Group 2008

The contents of this publication are the copyright of the publisher and may not be reproduced (even extracts) unless permission is granted. Every care has been taken to ensure the accuracy of the information contained in this publication but no liability can be accepted for any loss or damage whether direct, indirect or consequential arising out of the use of the information contained herein.

The data in this publication may differ from that shown in earlier publications because of redesign, technological developments or revised methods of calculation. SKF reserves the right to make continuing improvements to SKF products without prior notice with respect to materials, design and manufacturing methods, as well as changes necessitated by technological developments.

Publication **6234/I EN** · February 2008

Printed in Sweden on environmentally friendly paper.

skf.com