

Single- and Multi-circuit Pumps

for Circulating and Hydrostatic Lubrication
as Gear and Vane Pump Units, Reservoir Units

Gear pump unit



The pump units specified in this leaflet are lubricant delivery pumps without pressure relief fixtures and are designed for continuous operation in circulating and hydrostatic lubrication systems.

Units with one to twenty lubrication circuits are available.

Multicircuit gear pumps ensure a uniform delivery rate to individual feed lines and lubrication points against varying resistances.

Multi-circuit pump



These pump units may also be used for hydraulic tasks to the extent permitted by the pressure and viscosity ranges stated in the tables on the following pages.

The drive is provided by a three-phase motor designed for arated voltage of 230/400 V to DIN IEC 38. Specify special voltages, if required, when ordering.

The indicated delivery rate refers to an operating viscosity of $140 \text{ mm}^2/\text{s}$ at a back pressure of $p = 5 \text{ bars}$.

The permissible pressure and delivery rates vary with the viscosity. Pay attention to the respectively permissible viscosity!

When using oils with viscosities outside the indicated permissible ranges (spindle oils and highlyviscous oils), please ask for further information. Please note that even standard oils may become extremely thin-bodied or highly viscous due to changes in temperature.

Ambient temperature max. $+40 \text{ }^\circ\text{C}$
Lubricant temperature $0 \text{ }^\circ\text{C}$ to $+80 \text{ }^\circ\text{C}$

Single-circuit flangemounted units with integral cast valve chambers – Circulating lubrication

Type M units for mounting separately from oil reservoir

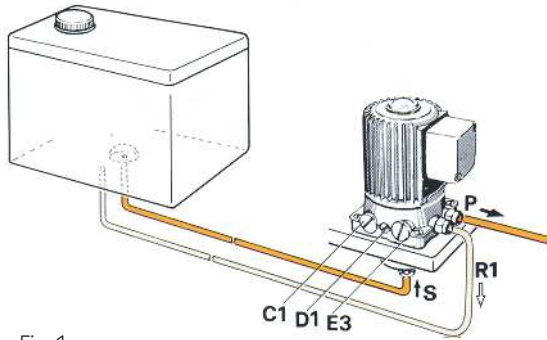

Fig. 1

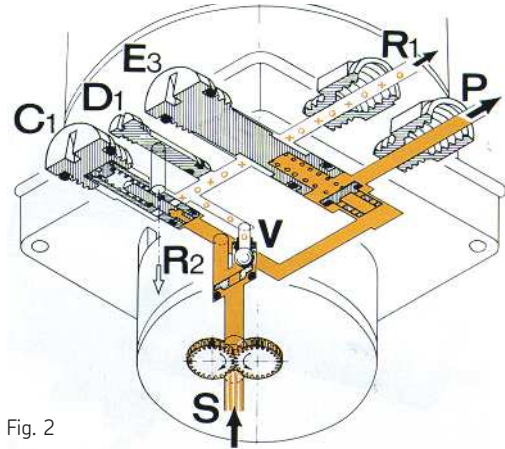

Fig. 2

Type MF units for flange-mounting on oil reservoir

Use a special sealed pump for horizontal flange-mounting of the unit beneath the oil level.

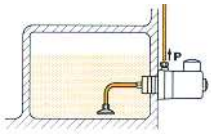

Fig. 3

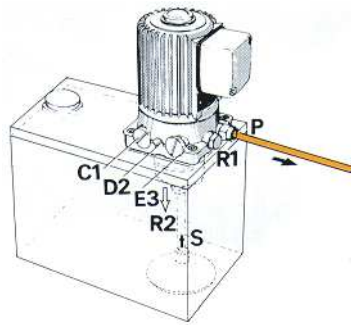

Fig. 4

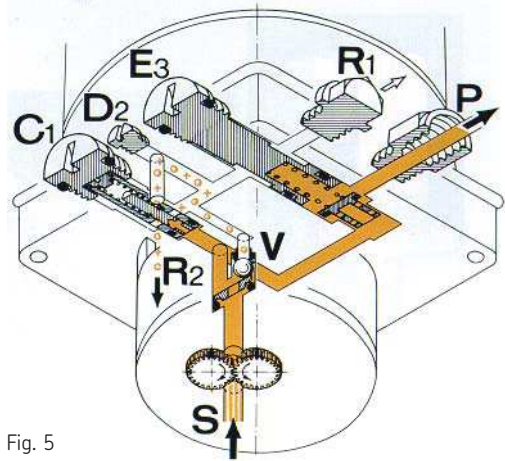

Fig. 5

Explanation of the hydraulic function

Both versions (M and MF) have the same hydraulic function.

Oil is sucked in at S and flows through the pressure duct in direction P. The oil pressure closes valve V and opens valve E3 against spring tension. If air is entrained (due to low oil level in the reservoir), valve V remains open and bleeds the air or the air-intermixed oil into the return duct (see circle (o) marking the flow in directions R1 and R2 respectively). Valve C1 allows the excess-pressure oil to flow into the return duct (see cross (+) marking).

Explanation of the structural differences

With type M the long screw plug D1 blocks flanged port R2 of the return duct. The oil returning from the valves V and C1 flows via R1 through a line of tubing into the separate oil reservoir (see Fig. 1 and 2).

With type MF, the short screw plug D2 leaves flanged port R2 open – contrary to D1 with type M – and a plug seals external port R1. Flanged port R2 of the return duct discharges directly into the reservoir without any threaded connections (see Fig. 4 and 5).

Single-circuit flangemounted units with integral cast valve chambers – Circulating lubrication

Fig. 6

See important product usage information on the back cover.

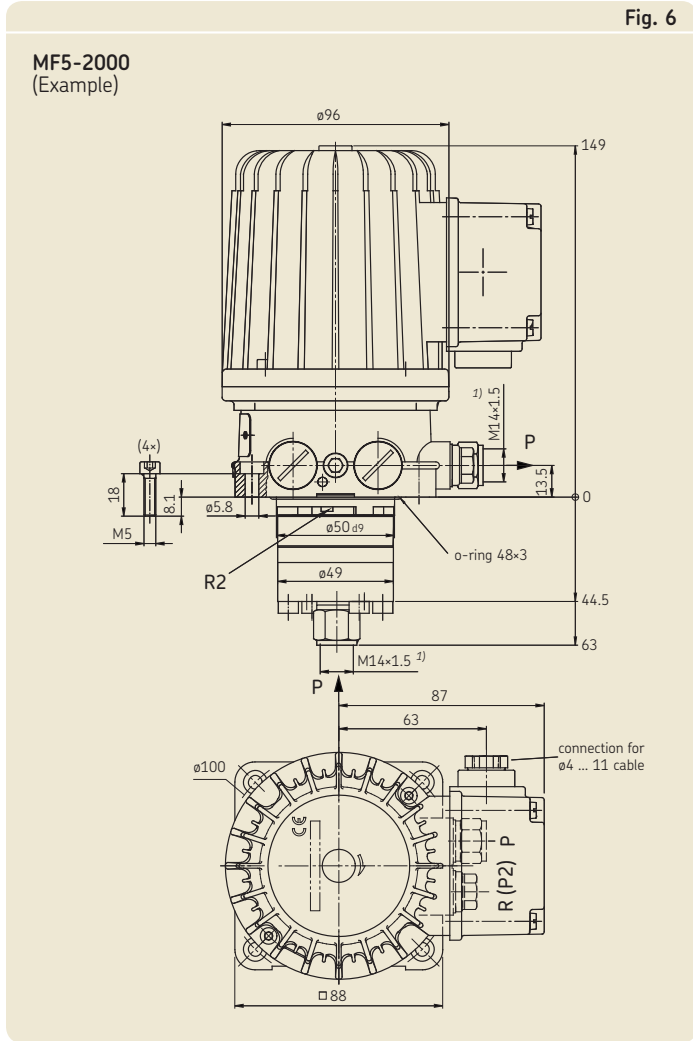

S = suction port
 P = pressure port
 R1 = oil return with type M
 R2 = oil return with type MF

- 1) Ports tapped for solderless tube connection, for 8 mm diam. tube.
- 2) Output based on an operating viscosity of 140 mm²/s at a back pressure of p = 5 bars.
- 3) Also see leaflet 1-1202-EN page 6: Multirange voltage motors.

Single-circuit units complete with reservoir see page 13.

Single-circuit gear pump units – choice of equipment

For mounting separate from oil reservoir Order No.	For flange-mounting on oil reservoir Order No.	Output ²⁾ [l/min]	Max. back pressure [bar]	Permissible operating viscosity range [mm ² /s]	Suction head (with open pressure line) [mm]	Three-phase motor ³⁾		Rated current at 50 Hz, 230/400 V [A]	Suction port S thread d1
						Rated output [kW]	Rated speed [rpm]		
M1-2000	MF1-2000	0.12	27	20 - 2000	500	0.075	2700	0.5/0.29	M14x1.5
	MF1-2006	0.12	6	20 - 2000	500	0.075	2700	0.5/0.29	M14x1.5
M2-2000	MF2-2000	0.2	27	20 - 2000	500	0.075	2700	0.5/0.29	M14x1.5
M2-S14	MF2-S12	0.2	1...65	20 - 1000	500	0.18	2700	0.87/0.5	M14x1.5
	MF2-S12	0.2	1...65	20 - 1000	500	0.12	2700	0.79/0.46	M14x1.5
M2-2127	MF2-2127	0.2	60	140 - 1000	500	0.075	2700	0.5/0.29	M14x1.5
M5-2000	MF5-2000	0.5	27	20 - 1000	500	0.075	2700	0.5/0.29	M14x1.5
M5-2013		0.5	16	5 - 500	500	0.075	2700	0.5/0.29	M14x1.5
	MF5-2014	0.5	1...12	5 - 500	500	0.075	2700	0.5/0.29	M14x1.5
M5-S12	MF5-S12	0.5	60	140 - 1000	500	0.12	2600	0.68/0.39	M14x1.5
	124-012-211	0.75	100	20 - 750	700	0.18	1400		M10x1
	124-012-210	1.0	150	20 - 750	700	0.37	1400		M10x1
Vane cell pumps									
FLM12-2000	FLMF12-2000	1.2	6	20 - 850	3000	0.075	2700	0.5/0.29	M16x1.5
FLM24-2000	FLMF24-2000	2.4	3	20 - 500	1000	0.075	2700	0.5/0.29	M16x1.5

Single-circuit gear pump units – Circulating lubrication

Single-circuit gear pump units – choice of equipment

For flange-mounting on oil reservoir Order No.	For mounting separate from oil reservoir Order No.	Output ¹⁾ [l/min]	Max. back pressure [bar]	Permissible operating viscosity range [mm ² /s]	Suction head (with open pressure line) [mm]	Three-phase motor ²⁾ Rated output [kW]	Rated speed [rpm]	Rated current at 50 Hz, 230/400 V [A]	Dimension A [mm]
UC0.06-60	UD0.06-60	0.048	60	20 - 1000	700	0.18	1500	see motor rating plate	37
UC0.75-60	UD0.75-60	0.6	60	20 - 1000	700	0.18	1500		45
UC1.00-60	UD1.00-60	0.8	60	20 - 1000	700	0.18	1500		45
UC1.50-50	UD1.50-50	1.35	50	20 - 1000	700	0.18	1500		47
UC3.00-25	UD3.00-25	2.4	25	20 - 1000	700	0.18	1500		51

¹⁾ Output based on an operating viscosity of 140 mm²/s at a back pressure of $p = p_{max}$
²⁾ Also see leaflet 1-1202-EN page 6: Multirange voltage motors.

Fig. 7

Type UC

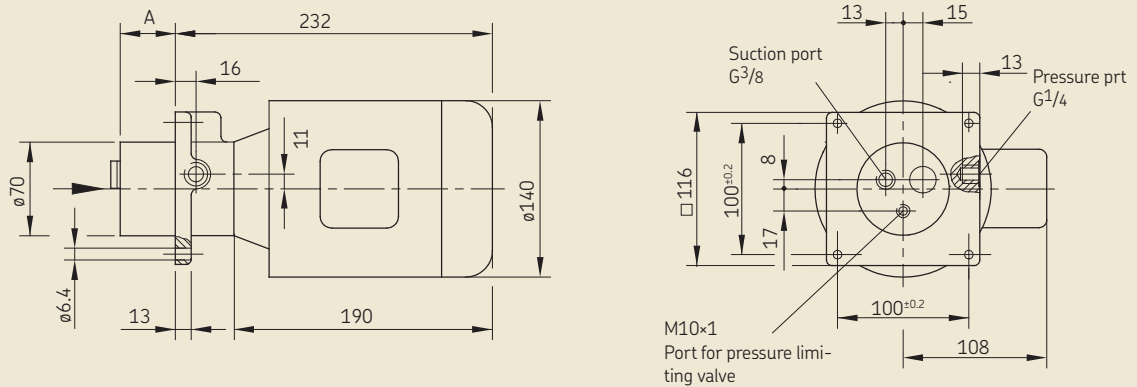
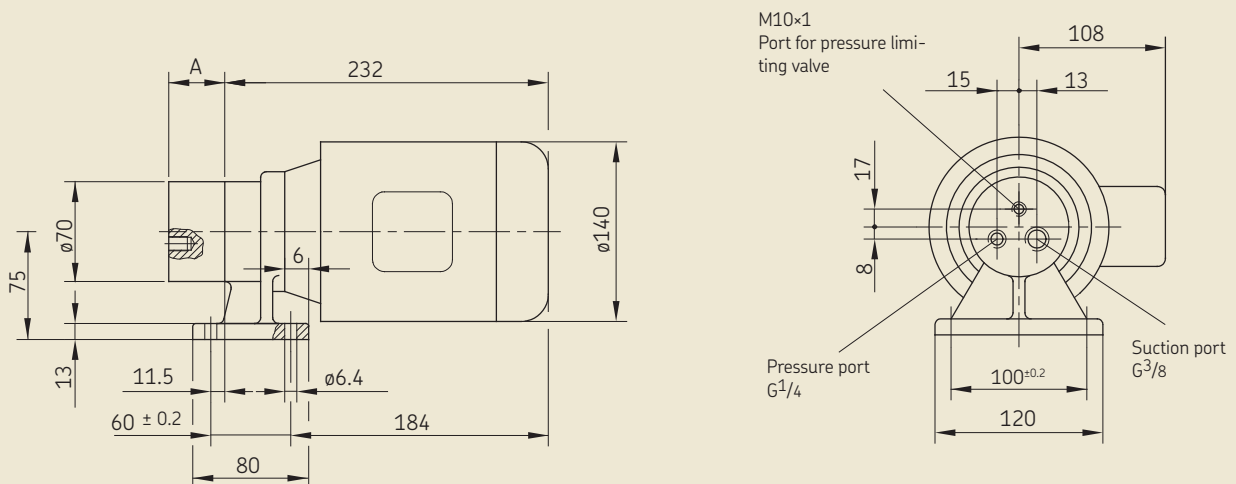

Fig. 8

Type UD



Two-circuit flange-mounted units, valveless – Circulating lubrication

Units for mounting separately from oil reservoir or for flange-mounting on oil reservoir

When a third gear is added to the pump, these units have a second delivery circuit (see P2).

Unlike single-circuit units M and MF described on page 2, these pumps are valveless (see changes in C2 and E4).

Since there is no internal oil return, there are no structural differences of the kind specified on page 2 for M and MF.

A special sealed pump must be used for horizontal flange-mounting of the unit in a position beneath the oil level (see Fig. 3 on page 2).

For two-circuit units complete with reservoir see page 13.

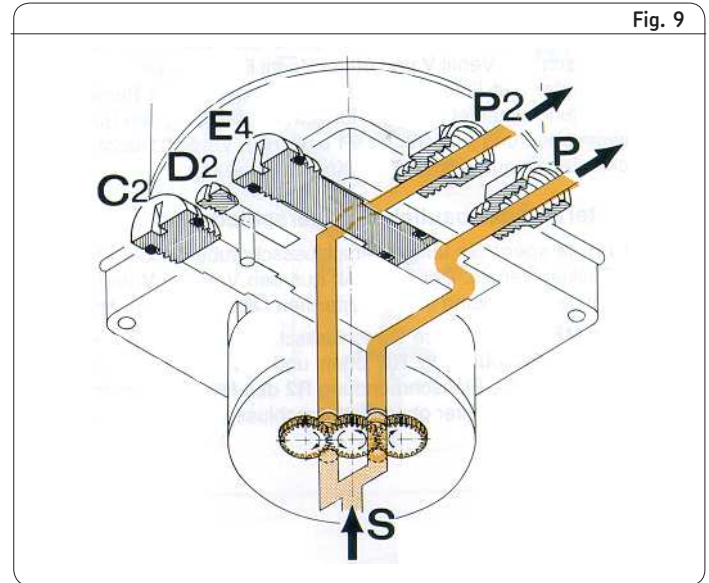

Fig. 9

Two-circuit gear pump units

Order No.	Output [l/min]	Max. back pressure [bar]	Permissible operating viscosity range [mm ² /s]	Suction head (with open pressure line) [mm]	Three-phase motor Rated output [kW]	Rated speed [rpm]	Rated current at 50 Hz, 230/400 V [A]	Suction port S (see Fig. 6, page 3) thread d1
M202	2× 0.2	12	20 - 1500	500	0.07	2700	0.5/0.29	M14×1.5 for 8 mm diam.tube
M205	2× 0.5	12	20 - 500	500				M16×1.5 for 10 mm diam.tube

Type of enclosure IP 54, DIN 40050



S = suction port
P and P2 = pressure ports
For dimensions see Fig. 6, page 3.
Mounting positions: vertically and horizontal

Layout of a circulating system with two-circuit gear pump unit

Fig. 10

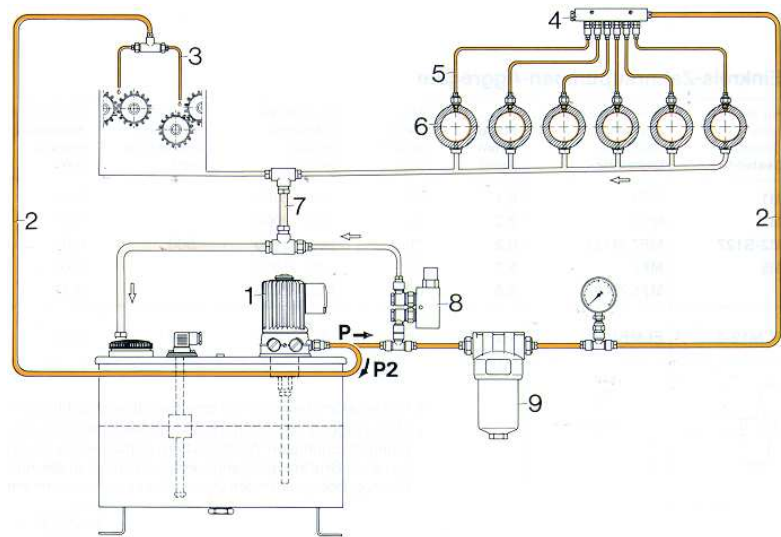

- 1 = two-circuit gear pump unit
- 2 = main line (two delivery circuits)
- 3 = restrictor tube
- 4 = manifold with metering valve distributors
- 5 = lubrication line
- 6 = lube point
- 7 = return line
- 8 = safety valve
- 9 = micro filter

Single-circuit gear pump units, valveless – Circulating lubrication

Fig. 11

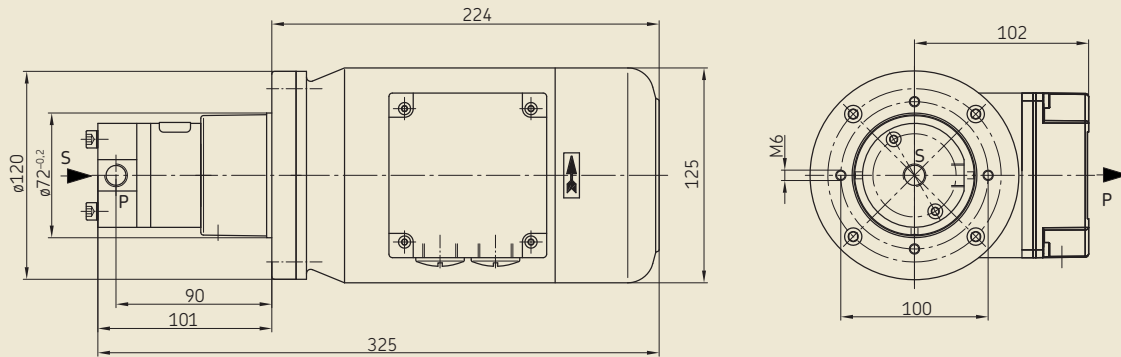
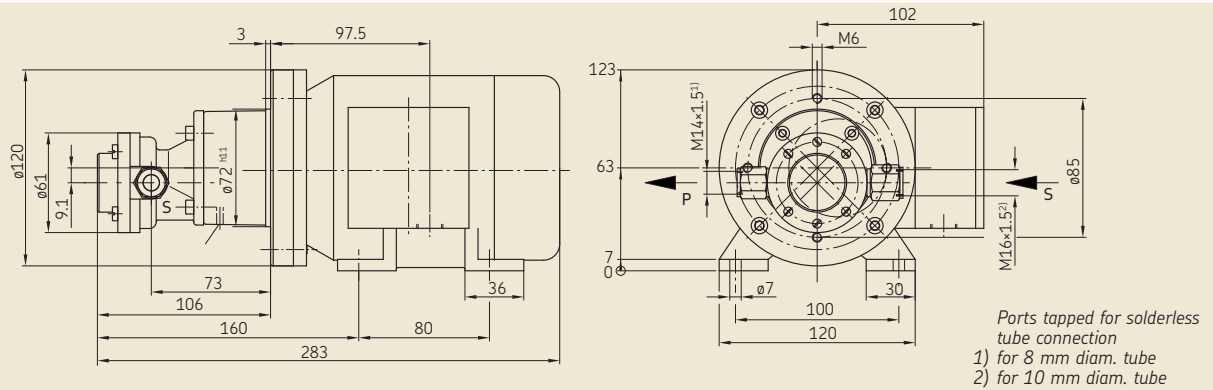
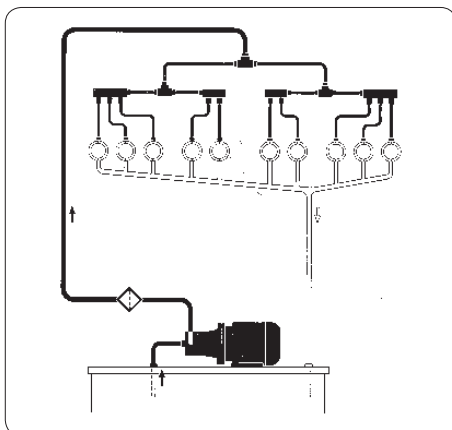

Fig. 12



Single-circuit gear pump units (suitable as priming pumps)

Foot-mounted units for separately-mounted from oil reservoir Order No.	Flange-mounted units for flange-mounting on oil reservoir Order No.	Output [l/min]	Max. back pressure [bar]	Permissible operating viscosity range [mm ² /s]	Suction head (with open pressure line) [mm]	Three-phase motor Rated output [kW]	Rated speed [rpm]	Rated current at 50 Hz, 230/400 V [A]	Fig.
ZM12-21	ZM12-31	1.2	30	20 – 2000	500	0.18	≈1350	0.6	11
ZM25-2	ZM25-3	2.5	20	20 – 2000	1000	0.18	≈1350	0.6	12



S = suction port
 P = pressure port
 Type of enclosure IP 54, DIN 40050

Units without foot have the same dimensions.

The dimensions and data indicated for the electric motors are recommended values and can be different in the case of individual manufacturers.

When special pressure relief and safety valves are used, the single-circuit pump units specified here may also be used for intermittently operated distributor systems if the units specially designed for this purpose, specified in leaflet 1-1202-EN do not meet the quantity requirements.

Special notes!

- Actual rotation of the motor must be the same as in the drawing to the left.
- When units are flange-mounted on the oil reservoir in a horizontal position, make sure the pump is not lower than the oil level (intermediate flange is not sealed.)
- If the unit is mounted separately from the oil reservoir, the suction side of the pump (S) may be connected to a higher oil reservoir (max. 2000 mm).

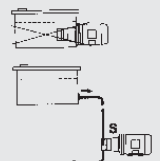

Two-circuit and five-circuit units, self-priming – Circulating lubrication without priming pump connection

Fig. 14

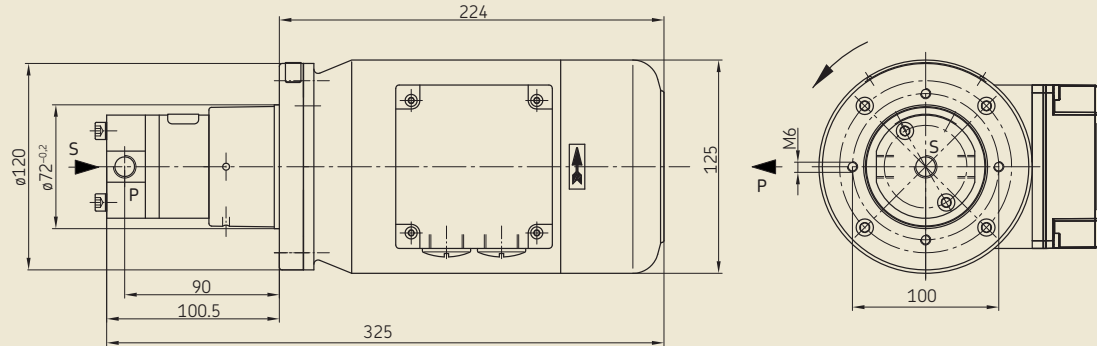

Two-circuit units

Foot-mounted units for separately mounted from oil reservoir Order No.	Flange-mounted units for flange- mounting on oil reservoir Order No.	Output at Va [l/min]	Vb [l/min]	Max. back pressure [bar]	Permissible operating viscosity range [mm ² /s]	Suction head (with open pressure line) [mm]	Three-phase motor Rated output [kW]	Rated speed [rpm]	Rated current at 50 Hz, 230/400 V [A]
ZM212-21	ZM212-31	1.2	1.2	12	20 – 2000	500	0.18	1300	0.6

Fig. 15

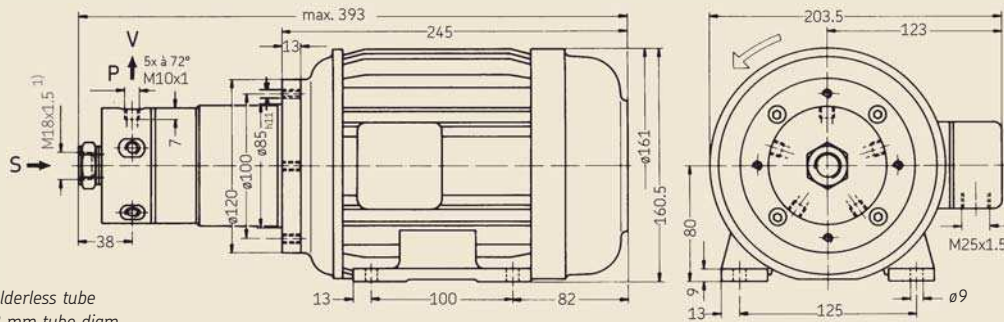

¹⁾ Port tapped for solderless tube connection, for 12 mm tube diam.

Five-circuit units *)

Foot-mounted units for separately mounted from oil reservoir Order No.	Flange-mounted units for flange- mounting on oil reservoir Order No.	Output at Va [l/min]	Max. back pressure [bar]	Permissible operating viscosity range [mm ² /s]	Suction head (with open pressure line) [mm]	Three-phase motor Rated output [kW]	Rated speed [rpm]	Rated current at 50 Hz, 400 V [A]
ZM502	ZM502-3	5 × 0.2	20	20 – 1000	500	0.25	670	1.22
ZM505	ZM505-3	5 × 0.45	10	20 – 500	500	0.25	670	1.22

*) If it is necessary to protect the individual pressure lines by safety valves, distributor manifolds, order No. 243-025.60 are available on inquiry.

S = suction port
P = pressure port
Type of enclosure IP 54, DIN 40050

Please pay attention to further notes on page 6.

Ten-circuit units, self-priming – Circulating lubrication without priming pump connection

Fig. 16

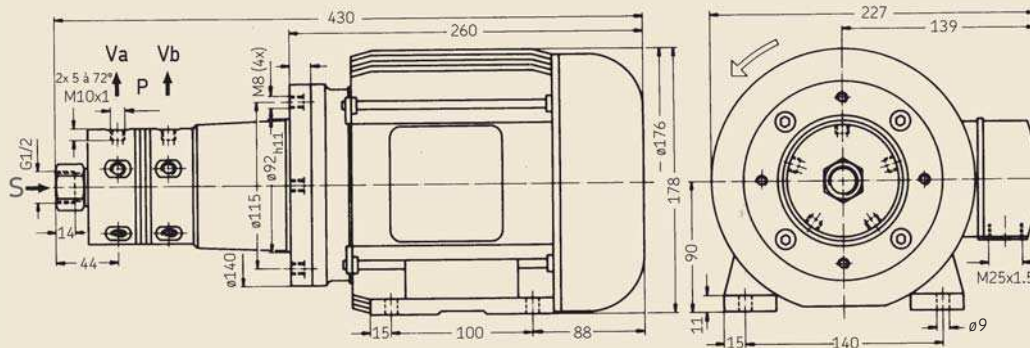

Ten-circuit units

Foot-mounted units for separately mounted from oil reservoir Order No.	Flange-mounted units for flange- mounting on oil reservoir Order No.	Output at Va [l/min]	Vb [l/min]	Max. back pressure [bar]	Permissible operating viscosity range [mm ² /s]	Suction head (with open pressure line) [mm]	Three-phase motor Rated output [kW]	Rated speed [rpm]	Rated current at 50 Hz, 230/400 V [A]
ZM1002	ZM1002-3	5 × 0.2	5 × 0.2	20	20 – 1000				
ZM1005	ZM1005-3	5 × 0.45	5 × 0.45	10	20 – 250	500	0.37	690	1.3
ZM1025	ZM1025-3	5 × 0.2	5 × 0.45	15	20 – 500				

S = suction port
P = pressure port
Type of enclosure IP 54, DIN 40050

Please pay attention to further notes on page 6.

Any delivery ports not required must not be blanked off. The oil delivered through these ports must be returned to the oil reservoir.

Hydrostatic lubrication

In the case of hydrostatic bearings, the oil pressure appropriate to the bearing's load-carrying capacity is generated in pumps outside the bearing, the oil being delivered at this pressure to the bearing recesses. From there, the oil escapes through the bearing gaps.

The smaller the output per circuit, the lower the oil viscosity and the greater the pump pressure, and the more the flow rates of the circuit will differ from each other.

The pressure difference within a multicircuit pump can be kept very small by utilizing a priming pump, which also helps to provide for uniform delivery rates.

The total capacity of the multicircuit pump and the recess pressure required per delivery circuit, with due consideration given to the permissible difference in pressures, is decisive when it comes to the choice of this priming pump.

By choosing the appropriate recess size, it is possible to keep the recess pressure within the desired limits. A medium-viscosity oil should be selected unless special tasks are involved.

With bearings that are subject to great pressure fluctuations, a proportioning pressure valve can be used to adapt the priming pressure to the particular pressure of a characteristic recess.

When a priming pump is used, a suitable filter can be installed in the priming pump's pressure line.

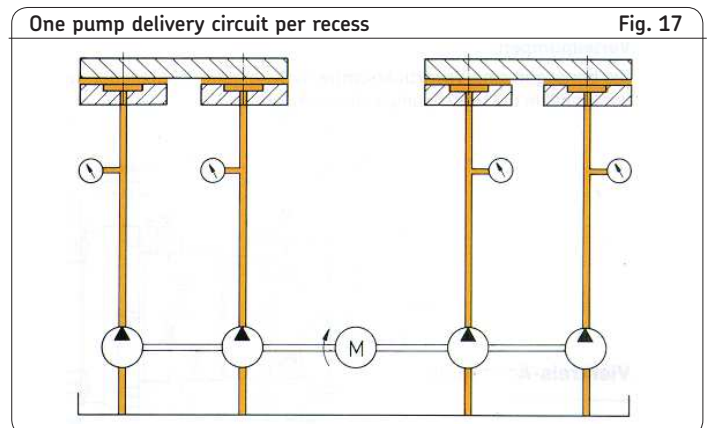

Fig. 17

Four-circuit units for operation with separate priming pump

Unlike the multicircuit pumps specified on pages 7 and 8, the pumps shown in figures 18-22 are operated as **distribution pumps**.

They require a **priming pump**, which is operated separately.
(For a selection of priming pumps, see the tables below.)

It is advisable to filter the oil upstream of the distribution pump inlet.

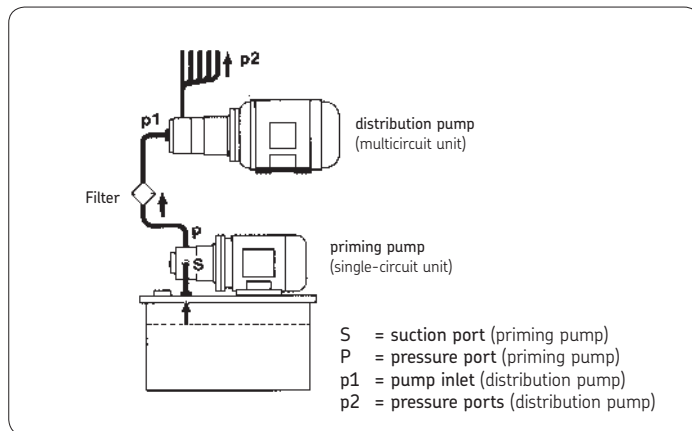
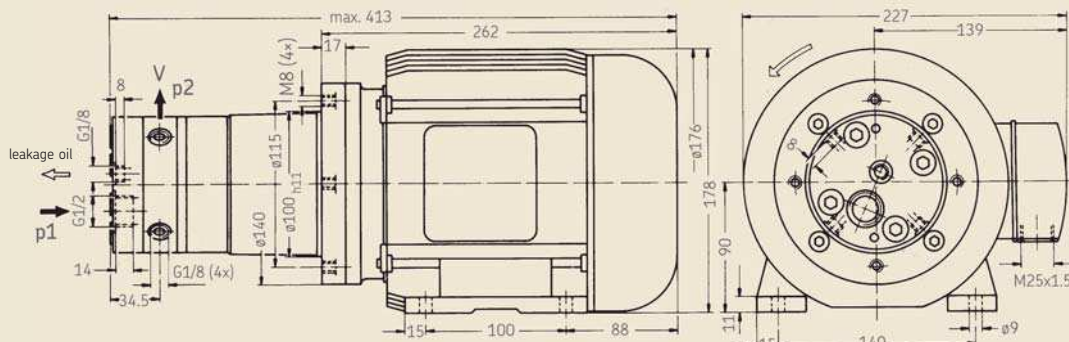

Fig. 18



Four-circuit units

Foot-mounted units
for separately
mounted from
oil reservoir
Order No.

Output
at V
[l/min]
4× 0.2
4× 0.45

Pump
inlet
max. p1
[bar]
50 (75)²⁾

Pressure
port
max. p2
[bar]
p1 ±5

Permissible
operating
viscosity range
[mm²/s]
20 – 500

Three-phase motor
Rated
output
[kW]
0.37

Rated
speed
[rpm]
690

Rated current
at 50 Hz, 400 V
[A]
1,3

Single-circuit units
suitable here as
priming pumps¹⁾
Order No.
ZM12-21
143-11...F02D-RA

Order No.
143-11...F05F-RA
143-11...F05F-RA

¹⁾ The priming pumps indicated here are foot-mounted units. For technical data on priming pumps, see pages 6 and 7. ²⁾ Values shown in brackets (): priming pump on inquiry.

S = suction port
P = pressure port
Type of enclosure IP 54, DIN 40050

The dimensions and data indicated for the electric motors are recommended values and can be different in the case of individual manufacturers.

Special notes!

1. Actual rotation of the motor must be the same as in the drawing.

2. If the priming pump is mounted separately from the oil reservoir, the suction side of the pump (S) may be connected to a higher oil reservoir (max. 2000 mm).

3. Any unneeded delivery ports of the multicircuit pump (distribution pump) must not be blanked off. The oil delivered through these ports must be returned to the oil reservoir.

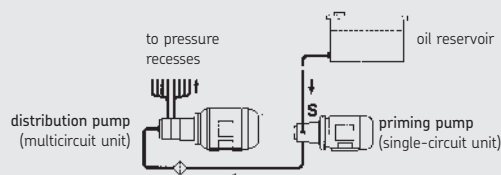

Five-circuit and eight-circuit units for operation with separate priming pump

Fig. 19

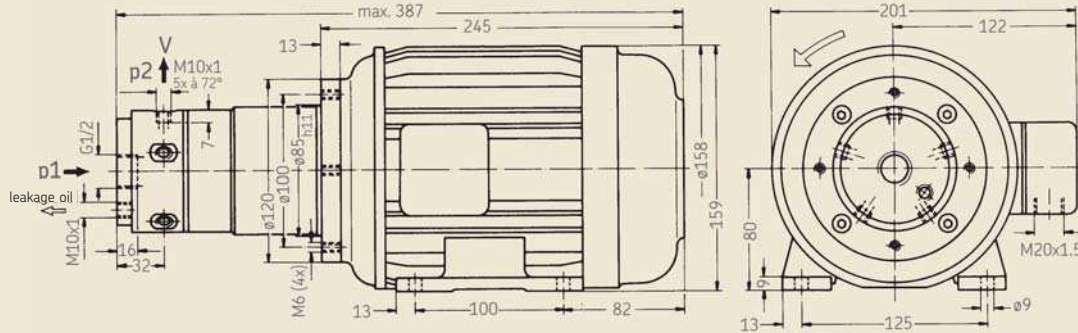

Five-circuit units

Foot-mounted units
for separately
mounted from
oil reservoir
Order No.

Order No.	Output at V [l/min]	Pump inlet max. p1 [bar]	Pressure port max. p2 [bar]	Permissible operating viscosity range [mm ² /s]	Three-phase motor Rated output [kW]	Rated speed [rpm]	Rated current at 50 Hz, 400 V [A]	Single-circuit units suitable here as priming pumps ¹⁾ Order No.	Order No.
ZM502-S2	5 × 0.2	30	p1 ± 5	20 – 500	0.25	690	1.05	143-11...F02D-RA	143-11...F05F-RA
ZM505-S2	5 × 0.45							143-11...H02F-RA	143-11...H05J-RA

¹⁾ The priming pumps indicate here are foot-mounted units. For technical data on priming pumps, see pages 6 and 7.

Fig. 20

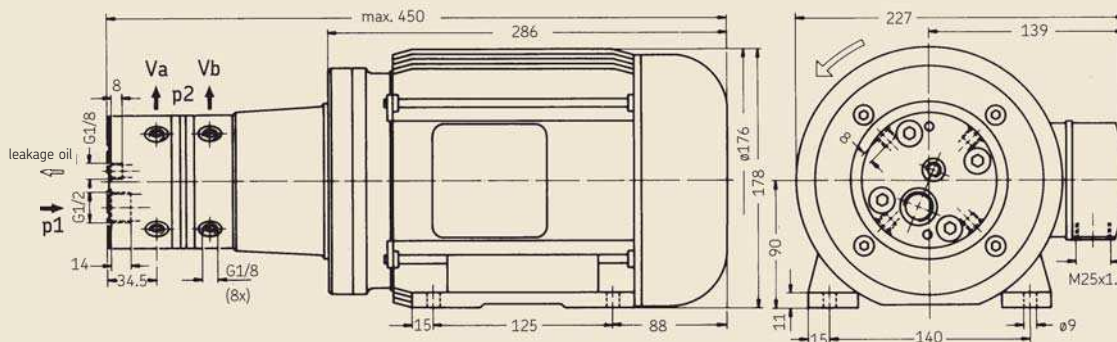

Eight-circuit units

Foot-mounted units
for separately
mounted from
oil reservoir
Order No.

Order No.	Output at Va [l/min]	Output at Vb [l/min]	Pump inlet max. p1 [bar]	Pressure port max. p2 [bar]	Permissible operating viscosity range [mm ² /s]	Three-phase motor Rated output [kW]	Rated speed [rpm]	Rated current at 50 Hz, 400 V [A]	Single-circuit units suitable here as priming pumps ¹⁾ Order No.	Order No.
ZM802-2-S2	4 × 0.2	4 × 0.2	50 (75) ²⁾	p1 ± 5	20 – 500	0.55	690	1.7	143-11...F02D-RA	143-11...F05F-RA
ZM805-2-S2	4 × 0.45	4 × 0.45							143-11...H02F-RA	143-11...H05J-RA

¹⁾ The priming pumps indicate here are foot-mounted units. For technical data on priming pumps, see pages 6 and 7. ²⁾ Values shown in brackets (): priming pump on inquiry.

S = suction port
P = pressure port
Type of enclosure IP 54, DIN 40050

Please pay attention to further notes on page 9.

Ten-circuit and twenty-circuit units for operation with separate priming pump

Fig. 21

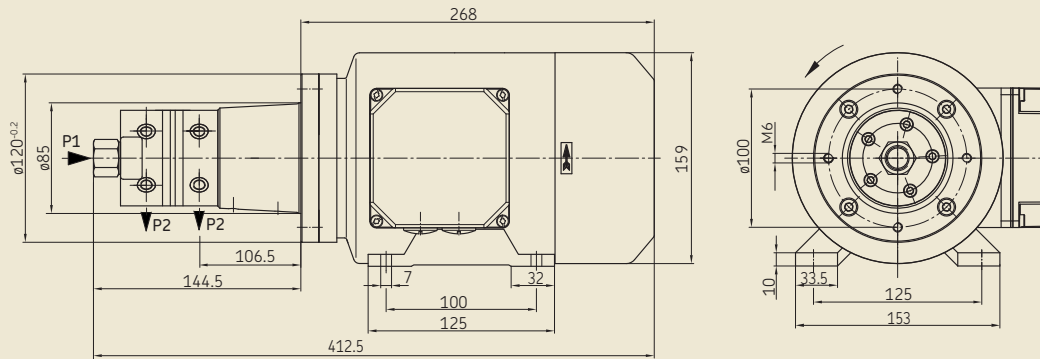

Ten-circuit units

Foot-mounted units for separately mounted from oil reservoir

Order No.	Output at Va [l/min]	Output at Vb [l/min]	Pump inlet max. p1 [bar]	Pressure port max. p2 [bar]	Permissible operating viscosity range [mm ² /s]	Three-phase motor Rated output [kW]	Rated speed [rpm]	Rated current at 50 Hz, 400 V [A]	Single-circuit units suitable here as priming pumps ¹⁾ Order No.	Order No.
ZM1002-S2	5 × 0.2	5 × 0.2	30	p1 ± 5	20 – 500	0.37	690	1.3	143-11...F02D-RA	143-11...F05F-RA
ZM1005-S2	5 × 0.45	5 × 0.45							143-11...K02H-RA	

¹⁾ The priming pumps indicate here are foot-mounted units. For technical data on priming pumps, see pages 6 and 7.

Fig. 22

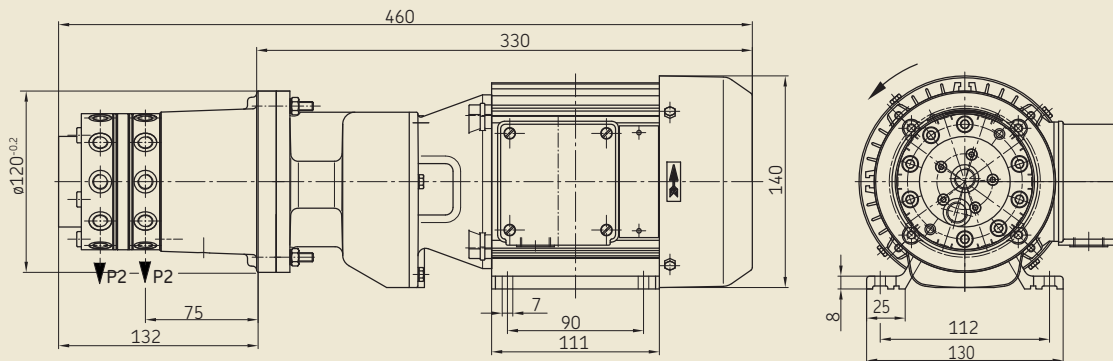

Twenty-circuit units

Foot-mounted units for separately mounted from oil reservoir

Order No.	Output ²⁾ [l/min]	Pump inlet max. p1 [bar]	Pressure port max. p2 [bar]	Permissible operating viscosity range [mm ² /s]	Three-phase motor Rated output [kW]	Rated speed [rpm]	Rated current at 50 Hz, 400 V [A]	Single-circuit units suitable here as priming pumps ¹⁾ Order No.
ZM2101-1	20 × 0.015	30	p1 ± 5	20 – 1000	0.18	1400	0.54	ZM12-21
ZM2102-1	20 × 0.03							ZM12-21
ZM2103-1	20 × 0.05							143-11...F02D-RA
ZM2104-1	20 × 0.1							143-11...F02D-RA

Type of enclosure IP 55

¹⁾ The priming pumps indicate here are foot-mounted units. For technical data on priming pumps, see pages 6 and 7.

²⁾ Based on an operating viscosity 140 mm²/s at a $\Delta p = 2$ bars.

Ten-circuit and twenty-circuit units with built-in priming pump and adjustable pressure limiting valve

Fig. 23

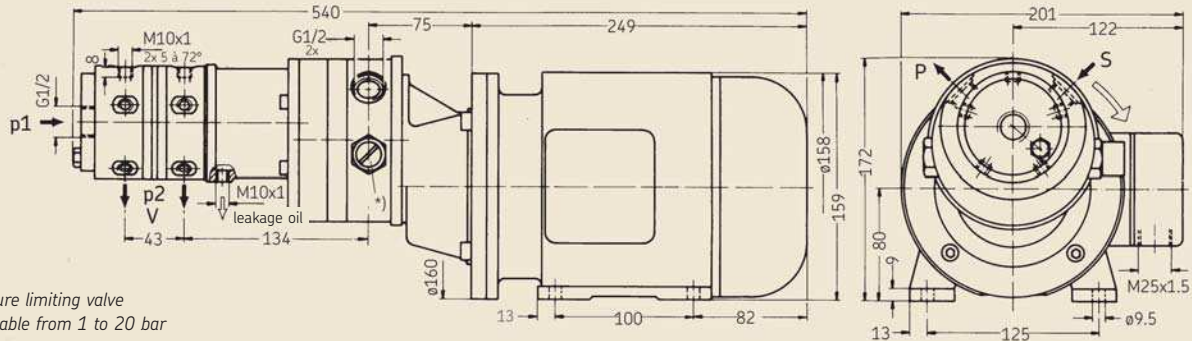

*) Pressure limiting valve adjustable from 1 to 20 bar

Ten-circuit units

Foot-mounted units for separately mounted from oil reservoir

Order No.	Output at V [l/min]	Pump inlet max. p1 [bar]	Pressure port max. p2 [bar]	Permissible operating viscosity range [mm ² /s]	Suction head (with open pressure line) [mm]	Three-phase motor Rated output [kW]	Rated speed [rpm]	Rated current at 50 Hz, 400 V [A]
ZM1035	10× 0.45	16	20	20 – 500	500	0.75	1400	2.0

Fig. 24

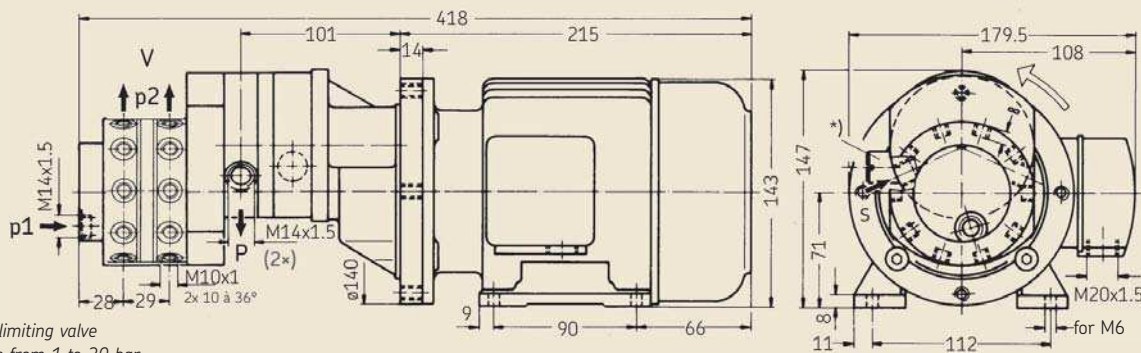

*) Pressure limiting valve adjustable from 1 to 20 bar

Twenty-circuit units

Foot-mounted units for separately mounted from oil reservoir

Order No.	Output at V [l/min]	Pump inlet max. p1 [bar]	Pressure port max. p2 [bar]	Permissible operating viscosity range [mm ² /s]	Suction head (with open pressure line) [mm]	Three-phase motor Rated output [kW]	Rated speed [rpm]	Rated current at 50 Hz, 400 V [A]
ZM2201	20× 0.025					0.12	680	0.67
ZM2202	20× 0.035	18	20	20 – 500	500	0.18	915	0.73
ZM2203	20× 0.05					0.37	1360	1.1

Type of enclosure IP 54, DIN 40050
Pay attention to direction of rotation, marked by arrow.

The dimensions and data indicated for the electric motors are recommended values and can be different in the case of individual manufacturers.

Any delivery ports not required must not be blanked off. The oil delivered through these ports must be returned to the oil reservoir.

Units complete with reservoir – Circulating lubrication

Pump units are also available mounted on reservoirs.

Capacities of reservoirs: 3, 6, 15, 50, 100, 200, 400 liters.

Pump units complete with reservoir may be comprised of the following:

- one or more pump units
- directional or safety valves
- pressure relief valves (when used for intermittent lubrication)
- filters
- return oil connections (R)
- oil level sight glass
- float switch (WS)
- cooling units
- pressure switches
- thermometers
- flow monitors
- pressure gauges
- pressure gauge protection valves
- pressure gauge selector valves (5 or 10 connections)
- heating elements

Examples of standard units with reservoir

Order No. ¹⁾	Reservoir capacity [Liter]	Reservoir material
...BW3-2	3	metal
...BW7	6	metal
...BW16	15	metal
...KW3-2	3	plastic
...KW6	6	plastic

¹⁾ The order number must be completed with the selected single- or two-circuit unit as detailed on pages 3 and 5.

Order examples:

Single-circuit gear pump unit MF2
with 6 liter plastic reservoir,
Order No.: MF2-2000-KW6

Two-circuit gear pump unit M202
with 15 liter metal reservoir,
Order No.: M202-BW16

Fig. 25

- ¹⁾ Port P tapped for solderless tube connection, M14×1,5 for 8 mm diam. tube.
- ²⁾ Connection for cable 7 to 9 mm diam.

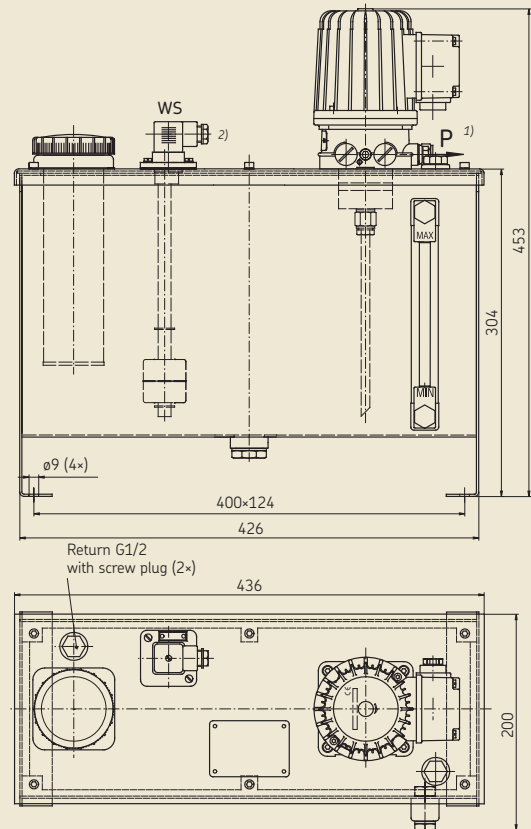
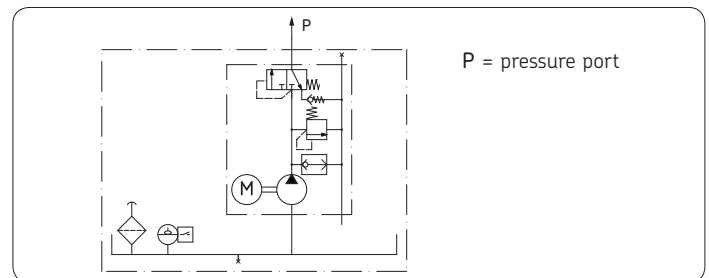

Fig. 25

Examples of a standard unit with 15 liter metal reservoir ...BW16



Standard dimensions of reservoirs starting at 30 liters

Reservoir dimensions [mm]

Reservoir capacity [liters]	Height		Width		Depth		Center distances		Hole \varnothing
	h	h2	h3	b1	d1	b2	d2		
30	375	245	237	510	320	430	240	14	
50	480	310	300	570	350	490	270	14	
100	510	340	326	710	500	630	420	14	
200	650	480	460	880	590	740	460	18	
400	850	650	626	995	711	900	620	18	

30 and 50 liter reservoirs available, also without legs, for wall-mounting. The complete order number for "completion according to customer's request" (in accordance with the information on page 14) must be specified when the order is placed.

- ① = oil filler cap
- ② = oil strainer
- ③ = float switch
- ④ = gear or gerotor pump unit
- ⑥ = oil level indicator
- ⑦ = oil drain plug

Reservoir and cover: hammered enamel finish

The complete reservoir units are also available in conformity with the regulations of the automobile industry. DIN and special reservoirs can be provided on request.

Fig. 26

Illustration 50 liter reservoir

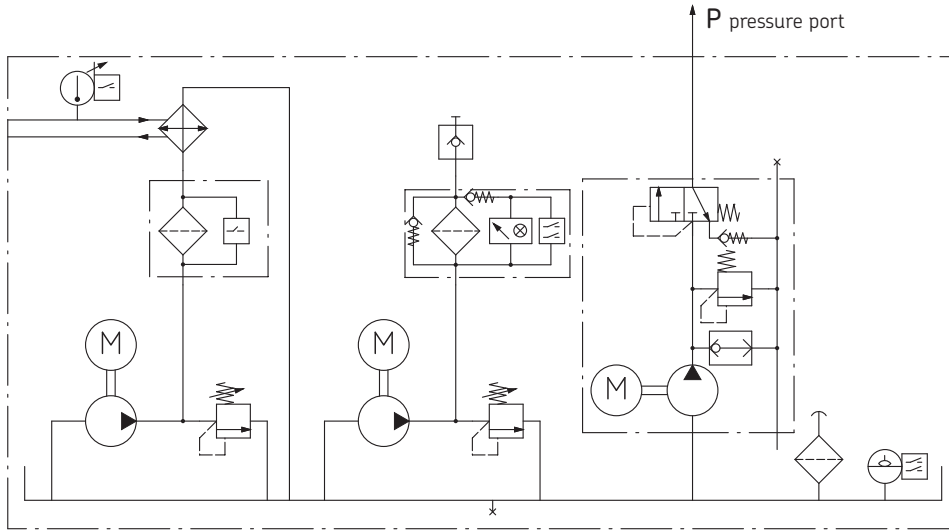
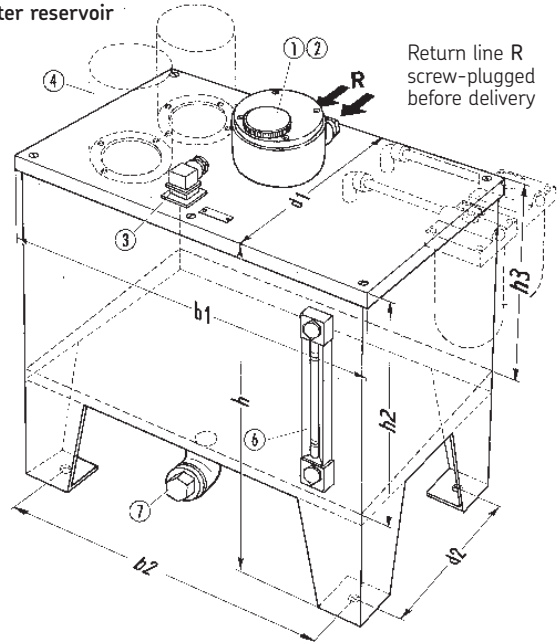

3-fold reservoir unit serving as a supply unit for a printing machine

The gerotor pump (delivery rate 9 l/min) is used to supply the gears in a circulating lubrication system and to provide for dissipation of heat at the same time.

The geroto pump (delivery 12.5 l/min) sucks the hot oil off again and feeds it back into the supply unit's reservoir via a cooler. That makes sure that appropriately cooled oil is always available for the gear circuit.

Another MFE5 unit is used to supply the cams with corresponding amounts of oil at specified intervals by way of piston distributors.

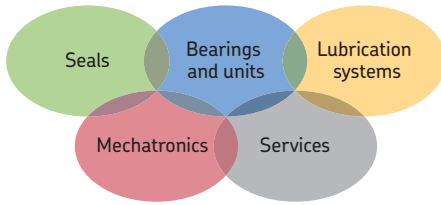

The Power of Knowledge Engineering

Drawing on five areas of competence and application-specific expertise amassed over more than 100 years, SKF brings innovative solutions to OEMs and production facilities in every major industry worldwide. These five competence areas include bearings and units, seals, lubrication systems, mechatronics (combining mechanics and electronics into intelligent systems), and a wide range of services, from 3-D computer modelling to advanced condition monitoring and reliability and asset management systems. A global presence provides SKF customers uniform quality standards and worldwide product availability.

Important information on product usage

All products from SKF may be used only for their intended purpose as described in this brochure and the operating instructions. If operating instructions are supplied together with the products, they must be read and followed.

Not all lubricants can be fed using centralized lubrication systems. SKF can, on request, inspect the feedability of the lubricant selected by the user in centralized lubrication systems. Lubrication systems and their components manufactured by SKF are not approved for use in conjunction with gases, liquefied gases, pressurized gases in solution, vapors or such fluids whose vapor pressure exceeds normal atmospheric pressure (1 013 mbar) by more than 0,5 bar at their maximum permissible temperature.

In particular, we call your attention to the fact that hazardous materials of any kind, especially the materials classified as hazardous by EC Directive 67/548/EEC, Article 2, Para. 2, may only be filled into SKF centralized lubrication systems and components and delivered and/or distributed with the same after consultation with and written approval from SKF.

Leaflet information:

1-0103-EN	Fittings and Accessories
1-1200-EN	Gerotor, Gear and Cam Pumps
1-1202-EN	Gear Pump Units
1-1203-EN	Compact Units for Oil
1-5006-EN	Circulating Lubrication Systems
1-9201-EN	Transport of Lubricants in Centralized Lubrication Systems

SKF Lubrication Systems Germany GmbH

Plant Berlin
 Motzener Str. 35/37 · 12277 Berlin
 PO Box 970444 · 12704 Berlin
 Germany

Tel. +49 (0)30 72002-0
 Fax +49 (0)30 72002-111

This brochure was presented to you by:

© SKF is a registered trademark of the SKF Group.

© SKF Group 2014

The contents of this publication are the copyright of the publisher and may not be reproduced (even extracts) unless prior written permission is granted. Every care has been taken to ensure the accuracy of the information contained in this publication. However, no liability can be accepted for any loss or damage whether direct, indirect or consequential, arising out of use of the information contained herein.

1-1204-2-EN · July 2014

This publication replaces publication 1-1204-EN.

