

SKF Multilog On-Line System IMx-8



User Manual Part No. 15V-090-00049-100
Revision A

⚠ WARNING! Read this manual before using this product. Failure to follow the instructions and safety precautions in this manual can result in serious injury, damage to the product, or unexpected results. Keep this manual in a safe location for future reference.

SKF Group

© SKF is a registered trademark of the SKF Group.
All other trademarks are the property of their respective owners.
© SKF 2017

The contents of this publication are the copyright of the publisher and may not be reproduced (even extracts) unless prior written permission is granted. Every care has been taken to ensure the accuracy of the information contained in this publication but no liability can be accepted for any loss or damage whether direct, indirect or consequential arising out of the use of the information contained herein. SKF reserves the right to alter any part of this publication without prior notice.

Patents: US 4,768,380 • US 5,633,811 • US 5,679,900 • US 5,845,230 • US 5,852,351 •
US 5,854,553 • US 5,854,994 • US 5,870,699 • US 5,907,491 • US 5,992,237 • US 6,006,164 •
US 6,124,692 • US 6,138,078 • US 6,199,422 • US 6,202,491 • US 6,275,781 • US 6,301,514 •
US 6,437,692 • US 6,489,884 • US 6,513,386 • US 6,633,822 • US 6,789,025 • US 6,792,360 •
US 7,103,511 • US 7,697,492 • WO/2003/048714

Product Support – Contact Information

Product Support – To request a [Return Authorization](#), [Product Calibration](#) or a [Product Support Plan](#), use the web page links for direct contact and support.

Product Sales - For information on purchasing condition monitoring products, services or customer support, contact your [local SKF sales office](#).

General Product Information

For general product information (i.e., product data sheet, accessories catalogue, etc.), visit the [Condition Monitoring Products](#) page on SKF.com and select the appropriate product link.

Technical Support Group

Discuss/review issues of specific interest with maintenance and reliability specialists from around the world at the [SKF Knowledge Centre](#).

For technical support, contact TSG-EMEA@skf.com for customers in Europe, the Middle East and Africa.
Telephone +46 (0) 31 337 65 00
or TSG-Americas@skf.com for customers in North America, South America and Asia.
Telephone +1 800 523 7514
Telephone in Latin America +55 11 4448 8620

Product Registration

Please take a moment to register your product at www.skf.com/cm/register to receive exclusive benefits offered only to our registered customers, including receiving technical support, tracking your proof of ownership, and staying informed about upgrades and special offers. (Please visit our website for more details on these benefits.)

Tell us how we're doing!

It's important that you're satisfied with the quality of our product user manuals. We appreciate your feedback; if you have comments or suggestions for improvement, [please tell us how we're doing!](#)

022017bt

Table of Contents

Introduction	1-1
Important Messages	1-1
System Overview.....	1-2
The IMx-8 Device	1-4
Installation	2-1
Installing the IMx-8 Device.....	2-1
Safety and Requirements.....	2-2
Planning the Installation	2-3
Cables and Connections.....	2-4
Data Communication	2-6
Device Configuration	3-1
Analogue in 1 to 8.....	3-1
Digital Input/Tacho Sensors.....	3-2
Relay Drivers	3-5
Modbus	3-6
Network Configuration	3-8
Network Data Transfer.....	3-8
Storage Capacity	3-10
Time Synchronization.....	3-10
System Security Considerations.....	3-11
Hardware Maintenance	4-2
Performance over Time	4-2

Electrical Waste	5-2
Technical Data	6-1
Environmental.....	6-1
Power.....	6-1
Analogue Inputs.....	6-1
Digital Inputs.....	6-2
Outputs	6-2
Analogue Measurement	6-2
Digital Measurement	6-2
Signal Processing.....	6-2
Interface.....	6-3
Storage Capacity	6-3
Data Processing.....	6-3
Miscellaneous	6-3
Quality Control.....	6-4
Troubleshooting Guide.....	7-1
Problems and Symptoms	7-1
Component Check.....	7-4
Summary	8-1
LED Status	8-1
Wire Connections	8-1
IMx-8 Drawings.....	9-1
Appendix A – Limited Warranty.....	10-2
Index.....	12-2

Introduction

Important Messages

The following messages are important information which require special care to have a safe and reliable IMx-8 system.

 ***Important messages, instructions and information in this manual must be carefully followed. Otherwise, harm might occur to equipment and/or personnel.***

 ***If the IMx-8 is mounted in an SKF cabinet, as described in section Installing the IMx-8 Device, to fulfil fire enclosure requirements the following must be ensured:***

- *The cabinet must always be mounted using all four supplied mounting brackets.*
- *All unused cable holes must be closed with the supplied blind plugs.*
- *All cable glands and blind plugs must be made of material with fire protection V-1 or better.*

 ***Note that the SKF Multilog IMx Manager app shall be used for SAT during/after the installation, as also for network configuration when required.***

Only authorized users will have access to the app and hence to modify the configuration on the IMx. Access to the app needs to be requested to CSG-Lulea@skf.com which in advance should have a list of authorized users, provided by the authorized representative of the company.

System Overview

The IMx-8 is a cost effective 8 channel condition monitoring device, that is certificated for wind power and marine industry environments, but can also be used across multiple segments.

In conjunction with the SKF @ptitude Observer Monitor Service and the SKF @ptitude Observer client, the IMx-8 forms a complete and flexible on-line condition monitoring system tool for rotating machinery applications, such as turbines, motors, pumps, fans, gearboxes etc. This enables acquired data trending and analysis, ensuring early identification of potential defects and the subsequent prevention of catastrophic machine failures.

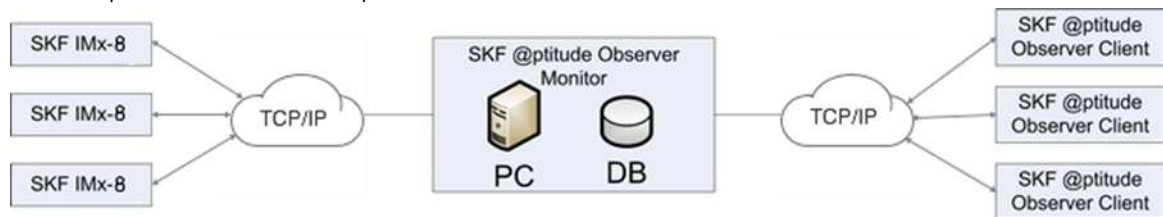

Figure 1-1.

Example of a System Overview of the SKF Multilog IMx-8 On-line System.

The figure above illustrates IMx-8 devices linked together in a network that is connected via LAN to @ptitude Observer Monitor Service.

The @ptitude Observer Monitor Service is connected to a LAN network, this allows several @ptitude Observer clients to link to the data.

The @ptitude Observer clients can be installed on the same computer as the @ptitude Observer Monitor Service.

Through a general OPC interface it is possible to link @ptitude Observer Monitor Service to an existing control or processing system, if desired.

The @ptitude Observer Monitor Service, @ptitude Observer clients and the database can be physically separated from each other if they are on the same network, where Microsoft SQL Server calls can travel freely.

It is also possible to connect different types of on-line devices in the same network, for example the SKF Multilog IMx-8 together with other IMx systems.

SKF Multilog IMx Manager – a mobile app for iOS and Android

In addition to the @ptitude Observer clients, SKF also provides the SKF Multilog IMx Manager app for iOS and Android. The app provides features to manage and configure the IMx system and to visualize measurement data.

The SKF Multilog IMx Manager connects to the IMx-8 device via Bluetooth. The app and the IMx have extended security connected to the user's SKF.com account.

The SKF Multilog IMx Manager mobile app allows you to:

- Perform network configuration tasks.

- Create standalone measurement configuration.

- View measurement configuration, as made via the @ptitude Observer client or via the SKF Multilog IMx Manager.

- Update the IMx-8 firmware.

- Select and download site specific machine templates.

- Run a SAT (Site Acceptance Test) based on the installed sensors by using live charts and plots and generate a SAT Report with the relevant information.

- Generate an IMx report that shows general IMx information, current IMx network and Modbus configuration including the company and user details.

- Viewer; shows live data with bar charts, trends, time waveform and FFT. Note: Viewer works in stand-alone mode only.

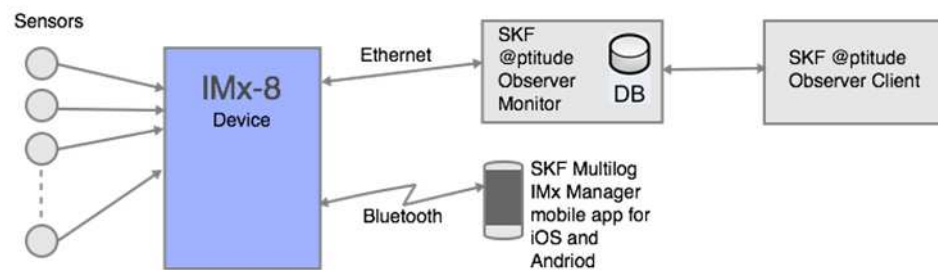

Figure 1-2.
IMx-8 Connections Overview

Stand-alone mode

The IMx-8 device can be configured to be used in stand-alone mode. In this scenario, a connection to the @ptitude Observer Monitor Service is not required as data is not transferred for trending and analysis by the @ptitude Observer Client. Instead, measurement data and alarms are displayed in the SKF Multilog IMx Manager app. For details on how to set up and configure the IMx-8 for stand-alone mode, refer to the SKF Multilog IMx Manager online help.

The IMx-8 Device



Figure 1-3.
The IMx-8 Device.

The IMx-8 is designed for use with machines for continuous analysis and monitoring, especially in places where periodic offline monitoring is not practical or when problems with the machines might occur suddenly. The IMx has special modes and on-board memory for local device data storage and subsequent data analysis via the app.

The IMx-8 device should be mounted in a location where vibration and temperature do not have an adverse effect on the device. (See Technical Data, section [Environmental](#) for more information on vibration tolerance and more.)

The IMx-8 device is designed for DIN rail mounting. The IMx-8 enclosure is IP30 classified. When higher environmental protection is required, an IP65 classified cabinet can be ordered from SKF Part Number CMON 4150.

Analogue Input Channels

IMx-8 has 8 analogue inputs with input range of ± 25 V. All channels are referenced to chassis/enclosure ground (all channels grounds are connected).

The analogue input supports 2-wire ICP-type sensors with its internal power supply (e.g. accelerometers).

The analogue input can also interface other 2-wire voltage output sensors with external power supply. Other types of sensors can be interfaced using external adapters.

Digital Input Channels

IMx-8 has 2 digital inputs. These digital inputs can interface with the most common standard types of digital inputs/sensors.

The digital input can interface with 2- or 3-wired speed sensors and/or CMCP 2505 (Eddy probe converters).

All channels are referenced to chassis/enclosure ground.

Network Configuration

The IMx-8 is by default configured as a DHCP-client to obtain its IP address automatically. For details on how to change the network configuration, refer to the [Network Configuration section](#).

All initiation parameters such as IP address, IMx identification number, etc. are stored first in a separate configuration file, then transferred to the IMx-8 device memory through the Online Device Configurator or the SKF Multilog IMx Manager mobile application.

Storage

Each IMx-8 device has 4 GB effective eMMC flash memory where:

- 1 GB is used for trend and dynamic data
- 1 GB is used for event capture data
- 2 GB is reserved for future needs.

Refer to the [Storage Capacity](#) section for more details on the amounts and kind of data that can be stored.

LED Indicators

The IMx-8 device has two LED indicators on the top endcap, a green LED for Power and a red LED for System, as shown below:



Figure 1-4.
LED Indicators on the top endcap.

While the main software is reading the configuration, and setting up the system, the SYS LED is fast flashing (approximately four times per second).

When the system configuration is done, the SYS LED will be turned off. There is a thirty seconds delay to ensure that the sensors are producing valid results before the system starts measuring.

2 Installation



Figure 2-1.
IMx-8 Device.

Installing the IMx-8 Device

The IMx-8 device comes in a painted aluminium enclosure that is IP30 classified. To provide higher environmental protection, the IMx-8 device should be mounted inside an IP65 classified cabinet (which can be provided by SKF). The IMx-8 device should be mounted at a location where it is not exposed to unnecessary radiant heat or strong magnetic fields.



Figure 2-2.
SKF IP65 Classified Cabinet with IMx-8 Device Mounted.

When using the SKF IP65 classified cabinet, always use the supplied mounting brackets. All the needed brackets, screws and gaskets are supplied with the cabinet.

When selecting type of cable glands, parameters such as IP-classification, cable shielding connection must be carefully considered in order not to compromise the IP65 certification level of the Cabine

When mounting the IMx-8 device in the cabinet, first attach the DIN rail bracket on the rear side of the device, as shown in the picture below. To mount the device on the DIN rail, first angle the device to hang it on the upper part of the bracket, in the center of the cabinet, and then snap it in place with the lower part of the bracket.



Figure 2-3.
IMx-8 Device with DIN Rail Bracket Attached.

To unmount the device, first snap the lower part of the bracket from the DIN rail and then lift it up a little bit. The device is now free to be lifted away from the DIN rail.

⚠ Important - To fulfil fire enclosure requirements, the cabinet must always be mounted using all four supplied mounting brackets.

Refer to [Environmental](#) in section Technical Data for detailed information.

The installation of an IMx-8 system must be carried out as described in the instructions and advice given in this manual.

If in doubt on how to install the device properly, please consult SKF personnel.

⚠ Important - Installation errors which require the involvement of SKF Condition Monitoring Centre Luleå personnel to rectify the start-up of the system, may incur additional charges.

Safety and Requirements

During the installation work, you should make yourself acquainted with the valid safety requirements for the site and requirements specific to the machine being

monitored. E.g. different types of machines can have different safety hazards and safety instructions. In all cases, read the instructions carefully and act accordingly.

 ***The warranty will be lost if the warranty seals are broken or if the IMx-8 device has been opened.***

Planning the Installation

It is important to assess and evaluate the site where the system is to be installed and to plan how the installation should look after it is completed.

Among other things, consider lengths of cables, where electrical power to the IMx-8 devices can be connected, where the @ptitude Observer Monitor Service should be installed and who should analyse the data. Good and thorough planning is the basis for a successful solution and installation.

Make a detailed layout of the equipment, the network, and distances between components. Include specifically the IMx-8 device, the SQL server computer, the @ptitude Observer Monitor Service computer and all hubs/routers in the network. Specify each component's network configuration such as IP addresses and subnet mask. Application engineers cannot help you if you do not have this information up front.

 ***Note that the SKF Multilog IMx Manager app shall be used for SAT during/after the installation, as also for network configuration when required.***
Only authorized users will have access to the app and hence to modify the configuration on the IMx. Access to the app needs to be requested to CSG-Lulea@skf.com which in advance should have a list of authorized users, provided by the authorized representative of the company.

SKF recommend use of the SKF Multilog IMx Manager app to generate an IMx report and a SAT report to document the parameters used to configure the IMx.

Note that a CAT5e/6 twisted pair (TP) Ethernet cable has maximum working distance of 100 m. If longer cable lengths are needed, fibre optic cables may be used along with needed converters, such as converters for fibre optic to CAT5e Ethernet and vice versa. When using fibre optics or PoE, these should be supported by and available on the converter.

Cables and Connections

Vibration Sensor Cable

When routing a vibration sensor cable, it is important that the cable is firmly fixed. The cable must not be allowed to vibrate or oscillate, since this affects the capacitance of the cable, and thereby the measurement result.

The sensor cable may not be routed or bundled together with high voltage cables, which generate strong magnetic fields, such as supplies to generator, electronic frequency converters, etc.

 **Important - In general, all cables must be routed as far away as possible from the high voltage electrical cables. If this cannot be done, care should be taken to use high quality shielded cables.**

Other Sensor Cables

To connect IMx-8 to other sensors, such as speed sensor, pressure sensor, data communication RS485, etc., use shielded, twisted pair 2 x 0.5 mm² (FKAR-PG 1 x 2 x 0.50, DUE 4002 or equivalent), with minimum voltage requirement of 300 V.

Cable Ends

For screw-less plug-in connectors, bootlace ferrules or cord end terminals is recommended for the wire ends. The wire end should have a maximum circular diameter of 1.5 mm² / 16 AWG and an insertion length of approximately 10 mm.

Supply Cable

To connect power to the IMx-8 device (24 – 48 VDC), Consult the local regulations for the installation site.

It is recommended that the IMx-8 device is connected to protective ground/earth (PE). Refer to Power In 24 VDC section for attaching power cable.

The IMx-8 DIN rail bracket is isolated from the housing. Use a braided ground strap to connect the IMx-8 to the ground rail. It is also possible to connect to instrument ground.

 **Important – The power supply cable must be properly fixed with a cable gland to prevent the cord from strain, twist or movement. See [Cable Glands](#) section as well.**

Cable Glands of IP65 Cabinet

If the IMx-8 device is mounted inside an IP65 cabinet, the shields of IMx-8 sensor cables should be terminated at the entrance to the cabinet and shielded from the cabinet by an insulating cable gland.

 **Important - All unused cable openings must be closed with blind plugs. All cable glands and blind plugs must be made of material with fire protection V-1 or better.**

Power In, 24 – 48 VDC

When mounting the DC power cable, connect the 24 – 48 VDC wire to pin + and the 0 VDC wire to pin -. The Power input is isolated from chassis/enclosure.

The equipment used for connecting DC power should be able to provide at least 13 W (24 – 48 VDC).

Refer also to Table 8-2: Wire connections for DC power input, in the Summary chapter.

Power over Ethernet (PoE)

The IMx-8 supports Power over Ethernet, PoE (<13 W), which means that there are two ways to provide power to the device, the ordinary DC power connection and PoE.

PoE may be used as an alternative or supplementary to the ordinary power supply. I.e., both the 24-48 VDC supply and the Power over Ethernet can be used as redundant inputs.

- Note: The Ethernet switch/router you use must support PoE.

 **Important – SKF recommends that when using PoE, use a switch/adaptor of higher quality. A switch/adaptor of poorer quality may affect the performance.**

For more information on PoE, please refer to the PoE standard, IEEE 802.3af and 802.3at.

Refer to the [Power](#) topic in Technical Data section for power requirements.

 **Important – Make sure that the power is disconnected before the installation.**

Communication Cables

Ethernet:

For cable lengths up to 15 meters, it is recommended to use pre-fabricated FTP Ethernet twisted pair cable FTP type, CAT5e/6.

For longer cable length, it is recommended to use S-FTP (screened shielded twisted pair) Ethernet cable CAT5e/6.

For grounding of shielded Ethernet cables; single-point ground of the shield is recommended at the hub/switch end of the cable. Do not connect the Ethernet cable shield at the IMx-8.

RS485:

Two wire twisted pair with screen.

Data Communication

Ethernet

The IMx-8 has one standard RJ45 (10/100 Mbit) port for connection of a network cable. The Ethernet port has auto detection of crossover or straight through Ethernet cable connection. If the system is correctly connected to another network device, the green LED lights up. The yellow LED flickers when there is traffic on the network.

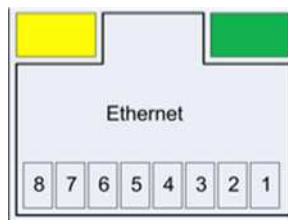

Figure 2-4.
Ethernet Outlet.

The table below shows how the pins of the Ethernet port are used.

Table 2-1: Ethernet Pins.

	SOURCE								LOAD		REMARKS
STANDARD	Ethernet RJ-45 connector pin number										
	Source Voltage	1	2	3	4	5	6	7	8	Load Voltage	DC Load Connector
IEEE 802.3af using data pairs	48 V DC, protected	RX, DC+	RX, DC+	TX, DC-	spare	spare	TX, DC-	spare	spare	(embedded)	Industry Standard for active PoE

IEEE 802.3af using spare pairs 48 V DC, protected RX RX TX DC+ DC+ TX DC- DC- (embedded)

Industry Standard for passive PoE

Refer to the tables in [Wire Connections](#) and the drawing of [Connectors and Switches Location](#) for connectors naming and location details.

Bluetooth

Bluetooth is used for communication between the IMx-8 and the SKF Multilog IMx Manager app. This is particularly useful when the IMx-8 is in stand-alone and SAT mode (but works in all modes). To communicate via Bluetooth, ensure that Bluetooth is activated on your mobile device. The Bluetooth dongle is specifically configured by SKF and provided mounted in the IMx-8 USB Type-A port on delivery of the IMx-8 device.



Note: SKF supports only Bluetooth v4.0, Low Energy (BLE).



Note: You can only use a Bluetooth dongle provided by SKF, since it need to be specifically configured for usage with the IMx-8 device.

Device Configuration

This section describes how to configure the IMx-8 device and how to connect different types of sensors, as well as how to connect the device to a network and alternative means to provide the device with power.

Analogue in 1 to 8

Connection of Accelerometers

Vibrations are measured by using accelerometers. Special care must be taken when positioning and mounting the accelerometer sensors. Otherwise, measurement results can be effected.

⚠ Important – How to attach sensors is described in the Attachment of Sensors for SKF Multilog Systems Instruction Manual. These instructions must be followed carefully to assure properly functioning condition monitoring.

To connect accelerometer sensor cables to IMx-8 devices, you need to use only two-wired sensors. IMx-8 supports both external powered accelerometers and standard accelerometers. The standard accelerometer power is turned on/off by software configuration. Refer to @plitude Observer User Manual for more information.

If e.g. using analogue channel A1 on the IMx-8, connect sensor output 1 (signal) to input A1 on the IMx-8 and sensor output 2 to input G1 on the IMx-8.

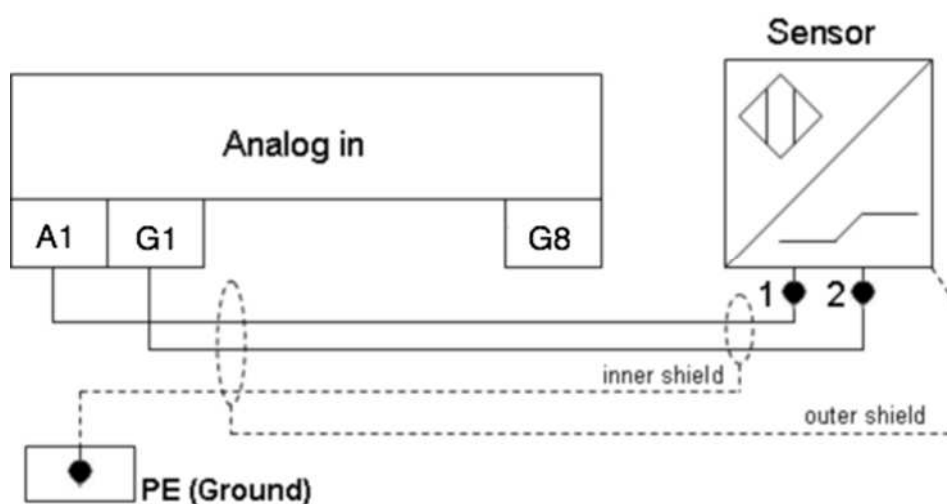

Figure 3-1.

Connection of Accelerometer Sensor Cables with Double Screen.

Note that the sensor shield should be connected either to the sensor or to the IMx-8 device depending on the cable and the sensor type, but NOT to both.

Connection to 4–20 mA signals

To connect signal of 4–20 mA, a resistor of 250 ohms provided by SKF must be used. There will be double deck connectors provided by SKF to facilitate the installation.

All ground terminals (G1 – G8) of the analogue inputs are connected to each other, to secure a common ground level.

Note! All channels are referenced to chassis/enclosure ground, take care to avoid ground loops!

Digital Input/Tacho Sensors

Connection of Pulse Transmitter (Tacho Sensor)



Figure 3-2.
Connection of Pulse Transmitter.

A pulse transmitter (tacho), linked to the IMx device, is used to measure rotational speed. The tacho sensor could be mounted to detect key or key-way. An example of such a sensor is shown in the figure of above.

A sensor with suitable sensing range must be selected and mounted with the correct range in both on and off position and handle thermal expansion, vibration,

torque movements that can happen once the machine starts running. See the installation instructions for the sensor type chosen.

Polarity can usually be changed by swapping wires.

Connection of Tacho/Speed Inputs

To connect the tacho/speed inputs to IMx-8 devices, both two- and three- wired tacho sensors are supported. They are two-wired, three-wired PNP, pulse source TTL and pulse source 12 – 24 V. The sensor input terminals that are used to configure the inputs, are shown in the following diagrams.

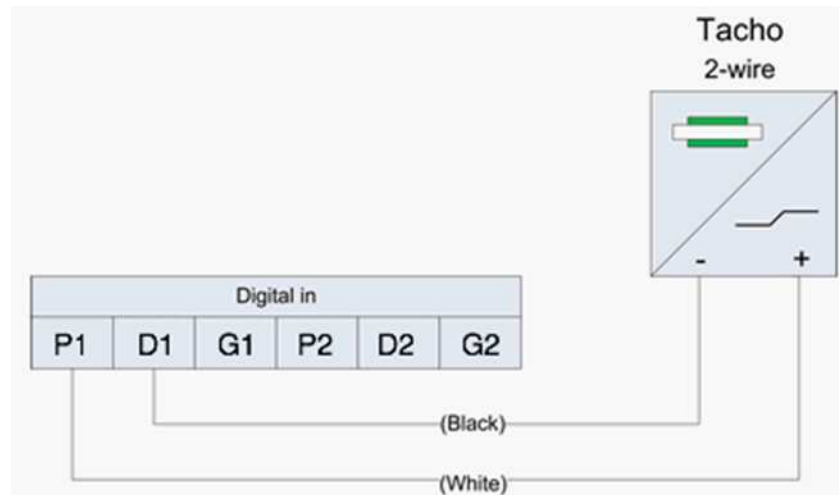

Figure 3-3.
Tacho Two-wire connections.

Three wired PNP is supported by both digital input channel 1 and 2.

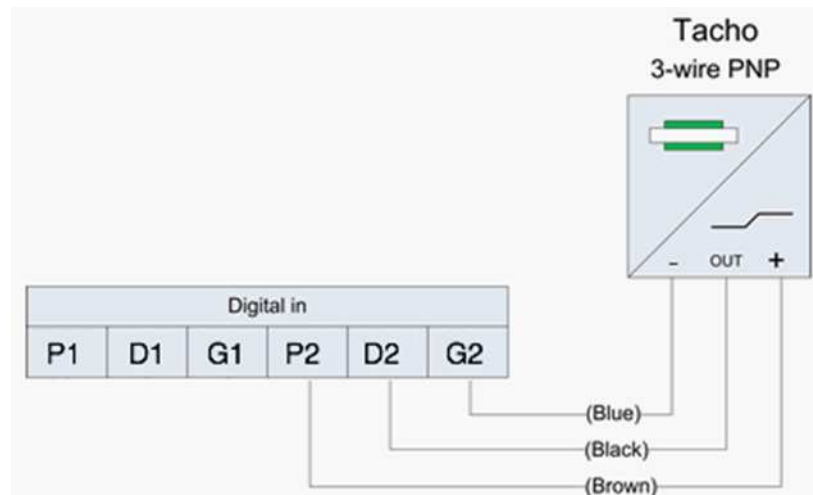

Figure 3-4.
Tacho Three-wire PNP.

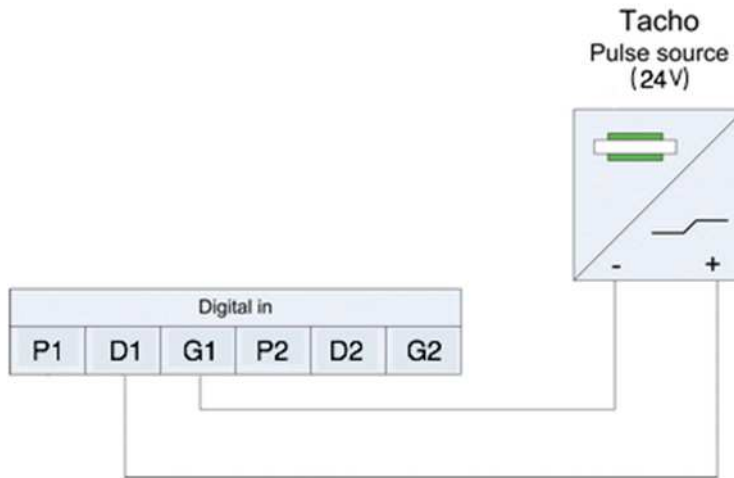

Figure 3-5.
Tacho Pulse Source connections (24 V).

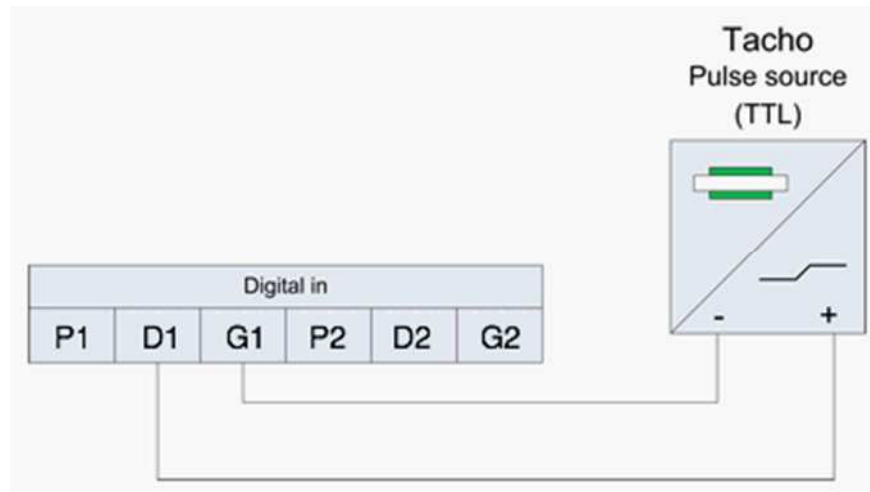

Figure 3-6.
Tacho Pulse Source connections (TTL).

Connecting Digital channel input/tacho channels

By default, the IMx-8 device is configured to supply power to both digital channel input/tacho channels (D1 and D2).

⚠ Note: There is no way to control the settings, or properties of the digital channel inputs. Neither in the hardware, nor through any specific software.

Table 3-1: Connector labels for some types of digital channel inputs/sensors.

Sensor type	Sensor Terminal	Wire colour	Digital Input 1	Digital Input 2
Tacho two-wire (24 V internally powered)	-	White	P1	P2
	+	Black	D1 G1	D2 G2
Tacho three-wire PNP (24 V internally powered)	+	Brown	P1	P2
	OUT	Black	D1	D2
	-	Blue	G1	G2
Pulse source (24 V) (external power)	+		P1 D1	P2 D2
	-		G1	G2
Pulse source (TTL) (external power)	+		P1 D1	P2 D2
	-		G1	G2

 **Note: It is possible to cascade one digital input with a sensor to another IMx-8 digital input without sensor by connecting D1 to D2 and G1 to G2.**

Refer to the tables in [Wire Connections](#) and the drawing of [Connectors and Switches Location](#) for connectors naming and location details.

Relay Drivers

The IMx-8 device has three relay driver outputs that can be connected to a relay as shown below and used to indicate System status, Warning by Alert and Alarm by Danger.

The system relay output can be configured by using new global threshold options in the system database, to enable various behaviour. (When a database is upgraded, to avoid changes on the previous configuration done by the user, the system relay setting is set to the old behaviour.)

The system relay driver is energized only when the system status is OK (indicated by the SYS led being off).

The system relay driver will be de-energized during power loss and when detecting internal system faults. The output will also be de-energized in case of a sensor cable fault or a cable faults from an external communication source, such as Modbus, if this behaviour is enabled by a new global option in the system database.

Note that the system relay will ignore Monitor connection and time sync errors and focus on errors that could disrupt alarms or warning detection.

For all three outputs in total, +24 V power is allowed for the maximum current of 70 mA.

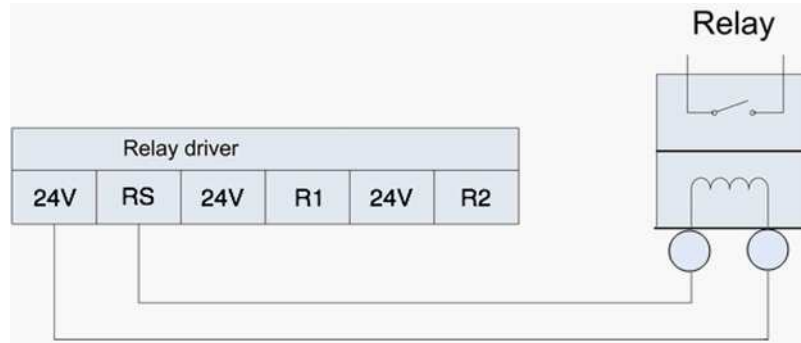

Figure 3-7.
Relay Driver Connection of One Output.

Refer to the tables and pictures in the [Summary](#) chapter for a complete list of connectors and how they are located on the device.

Note that the three 24V terminals always have the voltage +24 V each, whereas terminals RS, R1 and R2 are low side drivers known as open collectors (or 'open drain').

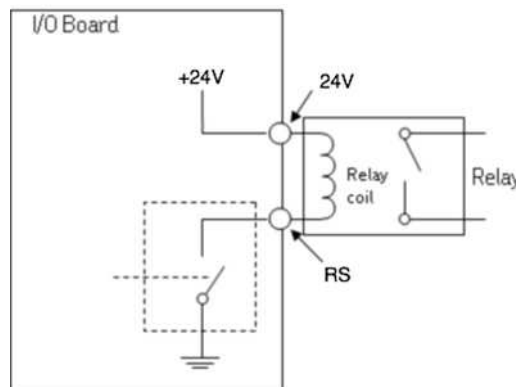

Figure 3-8.
Relay Open Collector Driver Showing Alarm Inactive.

Modbus

Modbus/TCP as well as the Modbus/RTU are supported by the IMx-8 device. Modbus transactions are performed one at a time in both master and slave mode.

Modbus is used to transfer measurement data from other systems to the IMx-8 device.

If the IMx-8 device is placed first or last in the Modbus/RTU bus chain, then an external bus termination must be connected.

***G3 (GND)** (see the diagram, below) - The devices that are connected to the Modbus must have the same ground potential. Therefore, ensure that all devices are connected to the same ground potential. When floating Modbus equipment is connected to the IMx-8 device's Modbus bus, the IMx-8 device's Modbus **G3** connector can be used to ensure the same ground potential for the Modbus bus. Normally, all devices are connected to the same ground connection. Make sure to avoid ground loops.

- Note – The IMx-8 does not provide fail-safe bias to the bus.

⚠ Important - To avoid ground loops, ensure that there is only one ground connection to each equipment. The IMx-8 device's G3 (GND) connector can be used in case where connected equipment bus is floating.

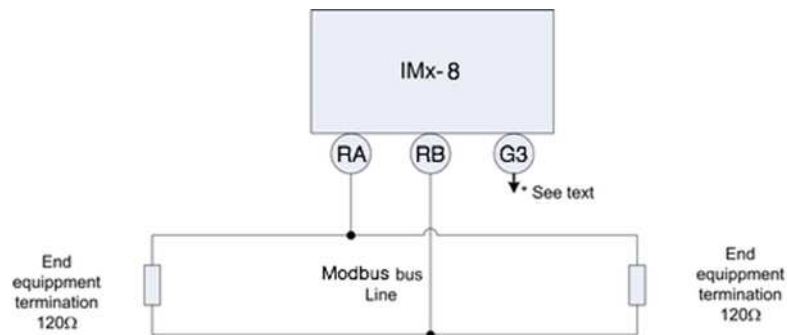

Figure 3-9.

Modbus Bus Connection and End Termination.

For more information regarding Modbus, refer to "Modbus for SKF IMx, @plitude Observer and IMx Manager user manual". Also, refer to the tables and pictures in the [Summary](#) chapter for a complete list of connectors and how they are located on the device.

For Modbus/RTU there is no built-in termination that can be activated. An external resistor of 120 ohms is provided by SKF as well as double deck terminals to facilitate the installation. The Modbus termination cannot be activated via online device configuration or by the IMx Manager.



Figure 3-10.
120 Ω resistor for Modbus/RTU Termination.

Network Configuration

All IMx-8 devices must have a unique identity number between 1 and 9999, referring to the database to which it is connected.

By default, the IMx-8 device's IP address is automatically set through DHCP, if there is a DHCP-server available on the local network.

If the IMx-8 device and the server are on the same local network, no server IP address needs to be configured. Otherwise, the server's IP address and the port number of the server where the @ptitude Observer Monitor Service runs, needs to be specified.

If the IMx-8 device is to be used in stand-alone mode (no server connected), the configuration of server IP address is disabled (N/A).

The network configuration is done with the On-line Device Configurator tool or the SKF Multilog IMx Manager mobile app. For detailed information, refer to **@ptitude Observer On-line Device Configurator User Manual** or the **online help** for the **SKF Multilog IMx Manager mobile app**.

Network Data Transfer

The IMx-8 system is continuously monitoring the machine condition from all sensor incoming signals and measurements shared by other systems via interfaces like Modbus or IEC61850 MMS.

The IMx-8 is connected to @ptitude Observer Monitor Service and data is stored in the database as specified by predefined operating and storage conditions such as trend and dynamic data time intervals, detected alarms from where a new storage interval is valid while the measurement point is in alarm status or based on exceptions defined by the difference in amplitude from the last two measurements.

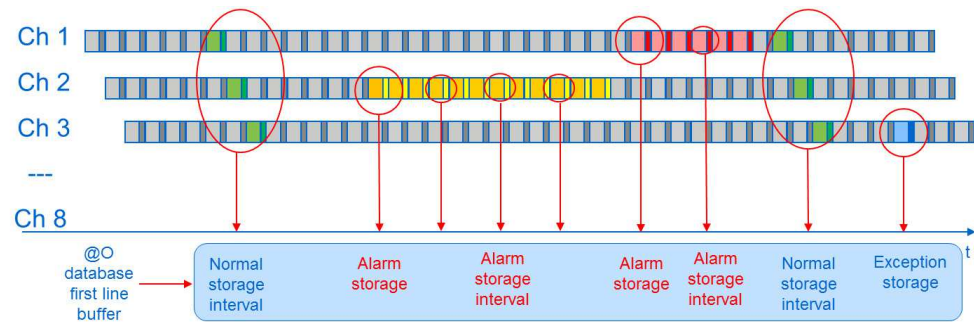

Figure 3-11.
Storage of Incoming Measurement Data.

The amount of the data transferred through the network is normally small and dependent on the IMx-8 configuration. In case of temporary loss of the network connection, data is still measured and stored locally, so that when the connection is re-established, collected data is transferred to the database.

This means that a connection can be as simple as a low byte rate modem, GSM, ADSL, normal internet or any other communications interface that provides an Ethernet port to connect to the IMx-8, and hence provide the connection to the @ptitude Observer Monitor database.

The following are some examples of network load from a normal configuration.

Trend data for 1 measurement point:

- Vibration measurement point = 160 bytes per trend value
- Other measurement point = 50 bytes per trend value

FFT spectra for 1 measurement point:

- Number of lines x 2 bytes (2 bytes if FFT spectra include only amplitude, but 4 bytes if FFT spectra include both amplitude and phase)

Time waveform storage:

- Number of lines x 5.12 bytes per measurement point (2 bytes per sample)

For a normal setup, we can calculate as the following:

Setup:

- 8 vibration measurement points (3200 lines)
- with time waveform
- 1 speed (tacho) measurement point
- We store FFT spectra with time waveform 1 per day, trend data every 10 minutes, and digital data every 10 minutes.

Calculation for data per day would be:

$$\text{FFT spectra} + \text{time waveform} + \text{trend data} + \text{digital data}$$

$$= (8 \times 3200 \times 2) + (8 \times 3200 \times 5.12) + (8 \times 160 \times 6 \times 24) + (50 \times 6 \times 24)$$

$$\begin{aligned} &= 51200 + 133120 + 184320 + 7200 \\ &= 375840 \text{ bytes per day or } 375.8 \text{ KB per day} \\ &= 11.3 \text{ MB/month (average of 30 days per month)} \end{aligned}$$

Storage Capacity

Each IMx-8 device has 4 GB effective eMMC flash memory used for the following:

1 GB for trend and dynamic data:

Depending on the measurement configurations and data storage schedule configured, the data could be buffered from a couple of weeks up to some years.

When the buffer gets full the oldest data is discarded – first in first out
Speed and process data use half the space of vibration data

1 GB for event capture data:

The number of events that can be stored depends on the number of channels used, number of samples per channel, number of speed pulses, internal flash sector alignment of data, and additional data provided with the capture.

For a maximum sized capture from an IMx-8, i.e. 8 channels, 10 kHz, 60 seconds, the buffer is capable to hold at least 30 captures. This scales with the number of samples in a capture, i.e. if number of channels or samples/channel is halved then the capacity for the number of captures stored is doubled.

When the buffer is full, no new captures will be triggered before there is enough space to store a new capture (when at least one capture has been uploaded to the server).

2 GB reserved for future needs

Time Synchronization

IMx-8 device has a backup power capacitor which will keep the time for approximately one week if the IMx-8 device is disconnected from a power inlet.

To correct or set the time, use one of the following methods.

Automatic time synchronization

This method is preferable since IMx-8 will continuously synchronize the time with the computer that has @plitude Observer Monitor Service running

IMx devices uses a standard (S)NTP time synchronization protocol supported by the Windows Time service.

To activate time synchronization, refer to the Time Synchronization chapter in "@ptitude Observer Installation Manual".

Manual set time

Use "Set time" function in @ptitude Observer which is found under a tab menu called "On-line", then "MasCon/IMx devices" interface.

For stand-alone configurations, the IMx-8 can still be configured to synchronize its time with a server configured by use of the SKF Multilog IMx Manager mobile app.



Important! For stand alone devices it is required to set a time synchronization server for the IMx-8 to have a proper time reference.

System Security Considerations

When configuring the IMx-8 as a stand-alone device using the IMx Manager mobile app, the IMx-8 device is linked to the company that the user doing the configuration represents. Non-authorized users or users from other companies will not be able to edit or view the information stored on the linked IMx-8 device.

Users of the IMx Manager mobile app will have access rights granted by their company's authorized representatives. The rights will allow them to either see the configuration of the IMx-8 and its measurements or both see this information and edit it.

Only one mobile device is authorized to be used per user. A lost device will mean that the user must contact CSG@skf.com to reset the device.



Note that all communication between the IMx-8 device and the IMx Manager mobile app is secured to avoid any other Bluetooth device to be used to hack the IMx-8.

Hardware Maintenance

The IMx-8 hardware, i.e. IMx-8 device and the sensors, are virtually maintenance free, however we advise the customer to do a yearly visual inspection of the equipment.

The IMx-8 device is designed not to be opened for hardware maintenance. In case of hardware failure; replace the faulty device with one that works.

 ***A good practice is to run the SAT at the recommended yearly inspection by using the IMx Manager app to generate the report to compare with the one provided during the installation of the system.***

Performance over Time

There is no significant performance degradation to be expected over time for the IMx-8 hardware.

Electrical Waste



Electrical waste and electrical equipment should be recycled as specified by the WEEE-directive and not be placed in the general refuse. Product should be sent to an approved recycling centre for safe recycling, recovery, reuse or sent to SKF Sverige AB for proper recycling.

SKF Sverige AB
Aurorum 30
97775 Luleå
Sweden

Technical Data

Environmental

Size (H x W x D): 104 x 173 x 40 mm (4.1 x 6.7 x 1.6 in.)

Weight: 410 g (0.9 lb.)

IP rating:

IP30, for the DIN Rail mounted enclosure

IP65, for the wall mounted SKF cabinet

Operating temperature range: $\square 40$ to $+70$ °C ($\square 40$ to $+158$ °F)

Storage temperature range: $\square 40$ to $+70$ °C ($\square 40$ to $+158$ °F)

Humidity: 95% (relative) non-condensing

Measurement category II

Pollution degree 2

Maximum altitude: 2 000 m (6 561.7 ft.)

Vibration tolerance:

4 - 13.2 Hz 1 mm.

13.2 – 100 Hz 0.7 g.

Number of axis: 3 mutually perpendicular.

Power

Power, 13 W:

- Power over Ethernet (PoE) 13 W; or
- 24 to 48 VDC. ($\pm 5\%$)

Power redundancy is possible.

Analogue Inputs

8 analogue single ended inputs, referenced to chassis/enclosure ground.

Input range ± 25 V

Software controlled power supply for standard accelerometers (4 mA constant current) for each individual channel

Can interface 2-wired ICP-type sensors (e.g. accelerometers) and/or voltage signals.

Simultaneous measurement of all channels.

Impedance >100 k \square



Max/min analogue input voltage for not causing damage to the device is ± 28 V

Digital Inputs

Two digital inputs, non-isolated, referenced to chassis/enclosure ground
24 V sensor supply, maximum 30 mA per channel.
Phase voltage range: up to 24V
Trigger level: 2.9 V (Hysteresis 0.1 V), Impedance 1.6 k Ω
Can interface 2- or 3-wired common speed sensors and/or CMCP 2502 (Eddy probe converters)

Outputs

Three relay outputs for indicating System status, Warning and Alarm

Analogue Measurement

24-bit AD conversion enabling continuous data capture without gain or AC/DC switching necessary
Simultaneous sampling of all 8 channels (no multiplexing), and one A/D converter for each channel
Simultaneous sampling of different channels with different sampling rates
Frequency range: from DC to 40 kHz
Dynamic range: 120 dB
Signal to noise ratio: 90 dB
Cross-talk rejection: 100 dB
Accuracy amplitude: $\pm 2\%$ (up to 20 kHz), $\pm 5\%$ (20 to 40 kHz)
Accuracy phase: $\pm 3^\circ$ (up to 100 Hz)
Automatic detection of sensor fault and cable fault (software configurable)
Maximum sampling frequency: 102.4 KHz (though lower for event capture)

Digital Measurement

Frequency range: 0.1 Hz to 20 kHz
Accuracy frequency: 0.05% of measurement value (typically 0.01% up to 2,5 kHz)
Pulse counting

Signal Processing

Time waveform
Vector analysis with circular alarms
FFT: 100 to 6 400 lines
SKF enveloping filters I, II, III, IV
Integration/Derivation in frequency domain

Window function: Hanning
Customer formulated mathematical equations
Dynamic alarm levels, active range determined on multiple parameters
Data storage on time, event or alarm condition
Detection of sensor and cable fault
Watchdog and self-testing

Interface

Ethernet: 100 Mbit/s RJ45, TCP/IP (one port)
USB Type-A (host interface for Bluetooth dongle)
USB Mini-B (device interface for service)
Bluetooth v4.0, Low Energy (BLE) smart SKF dongle, for Type-A USB
CAN-bus interface (CAN-bus communication ready, currently no firmware support)
Modbus RTU and Modbus TCP/IP interfaces for data sharing with other systems

Storage Capacity

4 GB effective eMMC flash memory (configured for pSLC mode which makes it more reliable compared to normal MLC mode which store 2 bits per cell for double capacity)

Data Processing

64 MB RAM for data processing

Miscellaneous

Calibration traceable to BIPM (international bureau of weights and measures)
CE certified in compliance with 2014/30/EU
EMC immunity in compliance with EN 61000-6-2:2005
EMC emission in compliance with EN 61000-6-4:2007/A1:2011
Support IEC 61850
DNV-G&L Renewables certificate – *valid for SKF Multilog IMX-8 only when the IMX-8 DIN rail version is mounted in a IP65 cabinet in a wind turbine that is built according to the DNV G&L wind turbine type approval* (pending approval)
DNV G&L Marine type approval (pending approval)
ABS Marine type approval (pending approval)
Lloyd's register Marine type approval (pending approval)

Quality Control

SKF Sverige AB's Condition Monitoring Centre Luleå is ISO 9001:2008 certified.

Troubleshooting Guide

Troubleshooting Guide is intended as an aid when the IMx-8 system is not functioning correctly.

It is designed for instrumentation engineers and others with sufficient knowledge of electrical troubleshooting in electronic systems with a 24 – 48 VDC power supply and of the risks that this can mean in case of incorrect procedure.

SKF Condition Monitoring Centre Luleå strives to provide information that is as accurate as possible. However, SKF Condition Monitoring Centre Luleå cannot be held responsible for any injury or damage to persons or material that can occur in the interpretation of, or due to actions taken based on information in this document.

IMx Manager SAT can be utilized for cable and sensor trouble shooting.

 ***Important - The guarantee becomes void if the IMx-8 devices are damaged through incorrect intervention in the hardware, or a patently incorrect connection in contravention of directions given.***

Problems and Symptoms

Sensor signal disappears or is abnormally changed for single channels

Possible causes:

- Broken sensor cable
- Short circuit in sensor cable
- Sensor fault
- Hardware fault with IMx-8 input stage

Suggested solution:

- Carry out sensor/cable test.

A sensor repeatedly generates a false alarm or varies abnormally

Possible causes:

- Broken sensor cable/contact
- Incorrectly mounted sensor
- Hardware fault with IMx-8 input stage
- Signal disturbed by external noise

Suggested solution:

First carry out sensor/cable test. In addition, check the sensor mounting. If this yields no result, contact SKF Condition Monitoring Centre Luleå.

Speed signal unobtainable/faulty for a certain machine

Possible causes:

- Cable fault (short circuit/broken) to speed sensor
- Faulty speed sensor, or faulty installation
- Speed signal too weak/impedance too high for IMx-8
- Faulty IMx-8 speed input
- Incorrect setting in hardware

Suggested solution:

Test speed input.

Analogue input gives faulty/no signal

Possible causes:

- Cable fault (short circuit/break) to sensor
- Faulty sensor
- Faulty grounding
- Incorrect setting in hardware
- Faulty IMx-8 input

Suggested solution:

Carry out control of sensor and cabling.

Load input gives faulty/no input signal

Possible causes:

- Cable fault (short circuit/break) to sensor
- Faulty sensor signal
- Faulty grounding
- Faulty IMx-8 load input
- Incorrect setting in software

Suggested solution:

The load input acts as an analogue input. Therefore, first carry out cabling/input test. Contact SKF Condition Monitoring Centre Luleå if this gives no result.

IMx-8 alarm relay does not activate despite of warning alarm

Possible causes:

- Cabling fault from IMx-8 to alarm panel
- Configuration error in software
- Hardware fault in IMx-8 device

Suggested solution:

Check the relay signal. Refer to "Checking relay signal" in Component Check of this chapter.

Monitor ceases to work from a certain IMx-8 device

Possible causes:

- Loss of voltage in IMx-8 device
- Hardware fault in IMx-8 device, such as power supply or processor module
- Break in Ethernet network

Suggested solution:

Check the voltage of IMx-8 device. In addition, check the Ethernet built-in LED indicator behaviour.

Monitor completely ceases to function

Possible causes:

- Monitor PC non-functional
- Monitor software incorrectly set
- Ethernet switch non-functional
- Cable break in Ethernet network
- Firewall configuration incorrect
- Database non-functional

Suggested solution:

Refer to "Checking monitor" in [Component Check](#) of this chapter.

Component Check

Checking sensor and sensor cabling for vibration channels

1. Determine the device number and channel number of the channel in question through the measurement point information in the software, or through the list of terminal blocks.
2. Measure the DC voltage between the sensor wires on the IMx-8 terminal block using a digital voltmeter. See the table below for the normal voltage values with and without a connected sensor respectively.

Table 7-1: Normal voltage

Sensor type	Normal operating bias voltage (DC V)	Open circuit voltage (DC V)
Standard accelerometer	8 to 12 V	+24 V

3. Is the voltage within the normal working range?

YES: The cabling to the sensor is probably Ok, and the sensor electronics have normal input impedance. If the sensor signal is still not perceived to be normal, one should try changing the sensor.

NO: Continue to step 5.

4. Does the fault remain after changing the sensor?

YES: The fault may be in the analogue input section of the IMx-8 device. Contact SKF Condition Monitoring Centre Luleå for service and further information.

NO: Sensor fault. The sensor is defective and must be replaced.

5. Is the voltage close to zero (typical $< \pm 0.5$ V)?

YES: There is probably a short circuit in the cable, or the sensor is defective. First, verify that the voltage rises to normal open circuit voltage when one of the sensor cable poles is disconnected from the terminal block of the IMx-8 device.

NO: Continue to step 9.

6. Did the voltage rise to normal open circuit voltage?

YES: Continue to step 8.

NO: The sensor is not receiving power, continue below.

7. Is the sensor a standard type?

YES: These are powered internally from the IMx-8 device. If the IMx-8 device does not supply open circuit voltage with input open, then the IMx-8 input is probably damaged, or the input is not configured to supply a power feed to the sensor. Contact SKF Condition Monitoring Centre Luleå.

8. The fault is in the sensor cable or the sensor. Go out to the sensor, and disconnect the cable at this end. Reconnect the cable on the IMx-8 terminal block, and again measure the voltage over these two poles. Does the short circuit remain?

YES: The sensor cable (or contact) has a short circuit. Repair the cabling.

NO: The sensor is defective. Replace the sensor.

9. Is the voltage close to the open circuit voltage?

YES: There is a break in the cable or the sensor is damaged. Continue below.

NO: If the voltage appears to be neither within the normal working range, close to zero nor close to open circuit voltage, then the fault is an unusual one. First, check that the measurement was correctly carried out, then contact SKF Condition Monitoring Centre Luleå. Remaining faults can be due to a damaged sensor or a damaged IMx-8 input. First, disconnect one pole of the sensor cable, and measure the open circuit voltage to verify whether the open circuit voltage is normal. If it is normal, then the fault is probably in the sensor, otherwise the fault is in IMx-8.

10. Disconnect the connector from the sensor and short circuit the pins in the sensor contact, then re-measure the voltage on the IMx-8 terminal block. Did the voltage sink to close to zero (<0.5 V)?

YES: There is an internal break in the sensor, or the contact is oxidized. First, try cleaning the contact before replacing the sensor.

NO: There is a break in the cable. Repair the cabling.

Checking sensor and sensor cabling for analogue channels

1. Determine the device number and channel number of the channel in question through the measurement point information in the software, or through the list of terminal blocks.
2. Measure the DC voltage between the sensor cable poles on the IMx-8 terminal block using a digital voltmeter.
3. Does the terminal block have the expected voltage level (see sensor sensitivity and the current actual value of the measured object)?

YES: The sensor and cabling are probably Ok. If the actual value is still not perceived to be normal, then the fault is probably in the channel settings, or there is a hardware fault in the IMx-8 device. Continue below.

NO: Continue to step 5.

4. Check through the current settings for the channel in question in the software. Determine the amplification, zero level, and the conversion to the user's device. Furthermore, the cable check must be off (N). If this still does not produce the correct actual value, then the input card is probably damaged. Contact SKF Condition Monitoring Centre Luleå.
5. The cable or the sensor is probably damaged. Test the cabling by disconnecting at the sensor end and connecting e.g. a 1.5 V battery. Does the input now measure the voltage?

YES: The sensor is probably not functioning correctly. However, first check that the channel is correctly configured with respect to the terminating resistor. In the list of terminal blocks, it can be determined whether the channel in question has a terminating resistor for current circuit. Check that this corresponds to reality, and that it corresponds to the sensor's mode of operation.

NO: The cabling is probably damaged. Continue to step 6.

6. Cable is probably damaged. However, first try disconnecting one of the poles on the cable from the IMx-8 terminal block. If the voltage is Ok, then the fault is in the IMx-8-device input stage. Otherwise, the cable is damaged and needs to be repaired.
7. Does the fault remain after replacing the sensor?

YES: The fault can be in the analogue input part of the IMx-8 device. Contact SKF Condition Monitoring Centre Luleå.

NO: It is a sensor fault. The sensor is defective and must be replaced.

Checking speed input

1. Determine the device number and speed input of the channel in question through the software measurement point setting or through the list of terminal blocks.
2. Measure the signal on the IMx-8 terminal block using an oscilloscope or similar. Make sure to use a potential free oscilloscope.
3. Is there an expected speed signal on the IMx-8 terminal block?

YES: The signal can be too weak or at too high impedance for the IMx-8 speed input to be triggered. Sufficient voltage ripple (peak to peak) is shown in the electrical specifications. If the signal level is sufficient, then the IMx-8 input is defective or the software is incorrectly configured. Check the settings in the program for the device number and input number of the speed measurement point. Contact SKF Condition Monitoring Centre Luleå for consultation.

NO: The cable is damaged, or the sensor is not sending the correct output signal. Check that the installation of the sensor is correct (is the machine rotating?). If this produces no result, check the cable. The entire chain from cable to input can be tested by linking a signal generator with a suitable frequency and amplitude at the sensor end. However, note that IMx-8 normally supplies power to a sensor (as shown in the equipment list), which is why a coupling capacitor must then be connected in series, to avoid ruining the signal generator.

Checking relay signal

1. Determine the device number of the alarming channel through the software measurement point setting or through the list of terminal blocks.
2. Disconnect the relay connection from the IMx-8 device in question. Carefully check to see if the relay output caused to trip the machines. Measure the voltage between the alarm relay poles.
3. Has the relay been activated (voltage approximately 24 V)?

YES: The fault is in the cabling or output connections from the IMx-8.

NO: Check the software configuration for measurement point settings to

find out whether the channel in question is allowed to activate the alarm relay. If this is not the case, then change the setting. Contact SKF Condition Monitoring Centre Luleå, if the channel is permitted to activate the relay, but does not do so.

Checking monitor

1. Check first, whether the @ptitude Observer Monitor Service PC is functioning as it should be.
2. Try restarting the computer, if there is any doubt as to the status of the @ptitude Observer Monitor Service software.
3. Check also that the Ethernet network is functioning and that the @ptitude Observer Monitor Service computer can write to the server disk.

Checking Modbus sensor

Please refer to the Modbus for SKF IMx and @ptitude Observer manual.

LED Status

Table 8-1: Status of LED indicators

LED Indicator	Behaviour	Description
PWR (green)	On	Power connected
	Off	Power disconnected
SYS (red)	Off	System configured & running (system relay normally energized)
	On	Severe error
	Fast flash (≈ 4 Hz)	System start-up or system configuration fault
	Slow flash (≈ 1 Hz)	Software configurable*. (See below)

*The slow flash functionality of the system LED is configurable by using the Observer client (default turned off). May e.g. be used to indicate sensor cable fault or cable fault from external communication source (e.g. Modbus) For configuration details refer to the Observer User Manual.

Wire Connections

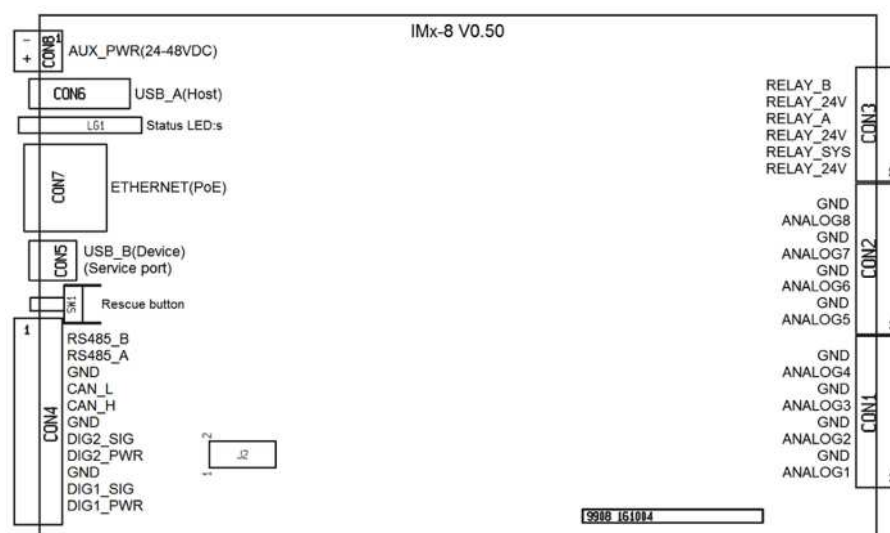

Figure 8 - 1.
Location of Connectors.

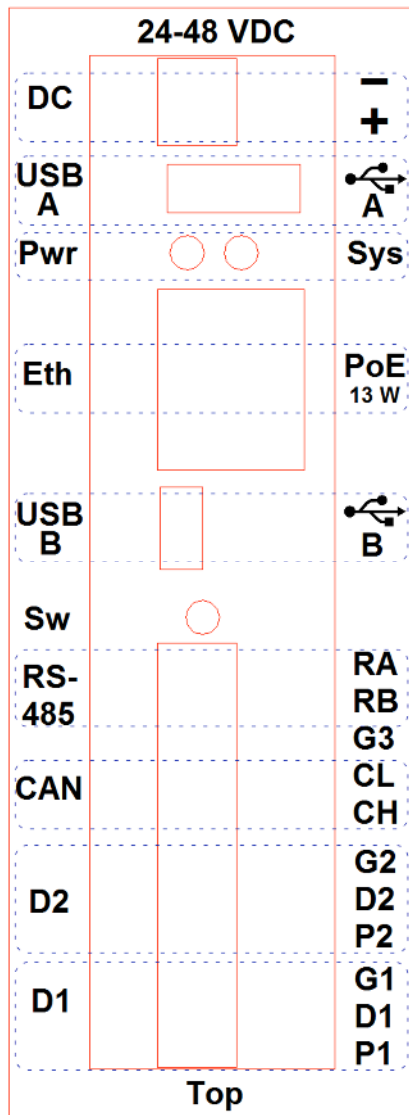

Figure 8 - 2.
Top Endcap Layout.

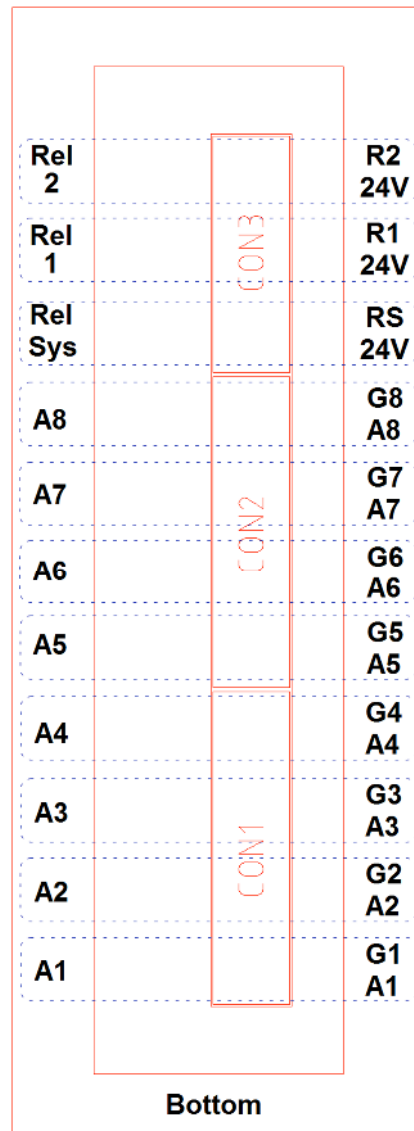

Figure 8 - 3.
Bottom Endcap Layout.

Table 8-2: Wire connections for DC power input.

DC input (CON8)	
Pin	Description
+	+24 – 48 VDC (isolated from chassis/enclosure)
-	0 VDC (unrelated to GND)

Table 8-3: Wire connections for analogue input 1 to 4.

Analogue input 1 to 4 (CON1)		
Channel	Pin	Description
A1	A1	Analogue in Ch1 (Signal)
	G1	Analogue in Ch1 (GND)
A2	A2	Analogue in Ch2 (Signal)
	G2	Analogue in Ch2 (GND)
A3	A3	Analogue in Ch3 (Signal)
	G3	Analogue in Ch3 (GND)
A4	A4	Analogue in Ch4 (Signal)
	G4	Analogue in Ch4 (GND)

Table 8-4: Wire connections for analogue input 5 to 8.

Analogue input 5 to 8 (CON2)		
Channel	Pin	Description
A5	A5	Analogue in Ch5 (Signal)
	G5	Analogue in Ch5 (GND)
A6	A6	Analogue in Ch6 (Signal)
	G6	Analogue in Ch6 (GND)
A7	A7	Analogue in Ch7 (Signal)
	G7	Analogue in Ch7 (GND)
A8	A8	Analogue in Ch8 (Signal)
	G8	Analogue in Ch8 (GND)

Table 8-5: Wire connections for relay driver 1, 2 and System.

Relay driver 1, 2 and System (CON3)		
Channel	Pin	Description
Rel Sys	24V	Digital out Relay_24V
	RS	Digital out Relay_Sys
Rel 1	24V	Digital out Relay_24V
	R1	Digital out Relay_1
Rel 2	24V	Digital out Relay_24V
	R2	Digital out Relay_2

Table 8-6: Wire connections for Modbus/RTU and CAN.

Modbus/RTU and CAN (CON4)		
Channel	Pin	Description
RS485	RB	RS485_B
	RA	RS485_A
Ground	G3	GND
CAN	CL	CAN_L
	CH	CAN_H

Table 8-7: Wire connections for digital/tacho in 1 to 2

Digital/Tacho in 1 to 2 (CON4)		
Channel	Pin	Description
D2	G2	Digital in Ch2 (GND)
	D2	Digital in Ch2 (Signal)
	P2	Digital in Ch2 (Power)
D1	G1	Digital in Ch1 (GND)
	D1	Digital in Ch1 (Signal)
	P1	Digital in Ch1 (Power)

IMx-8 Drawings

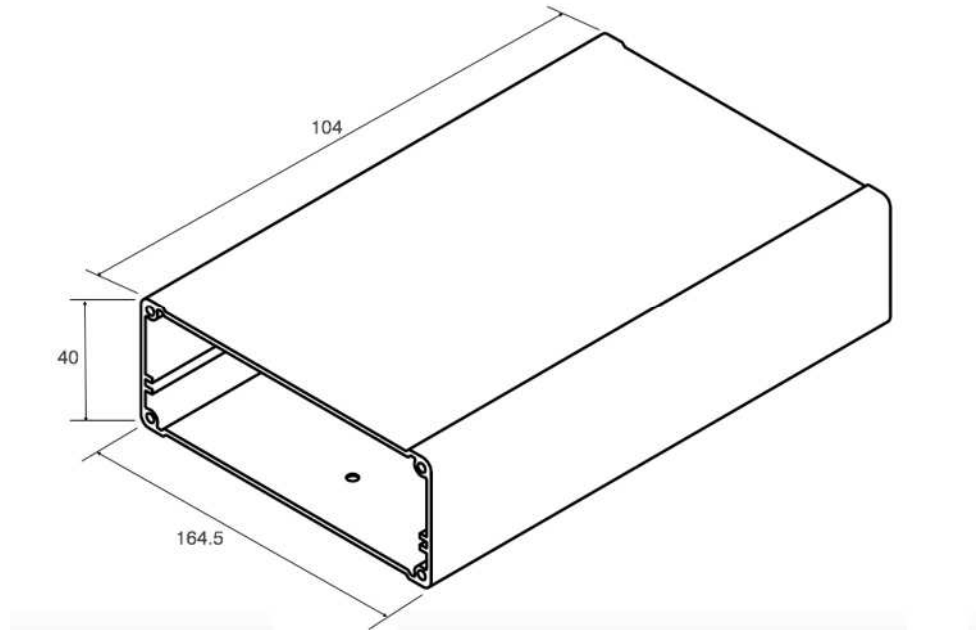

Figure 9-1.
Device Capsule Overview.

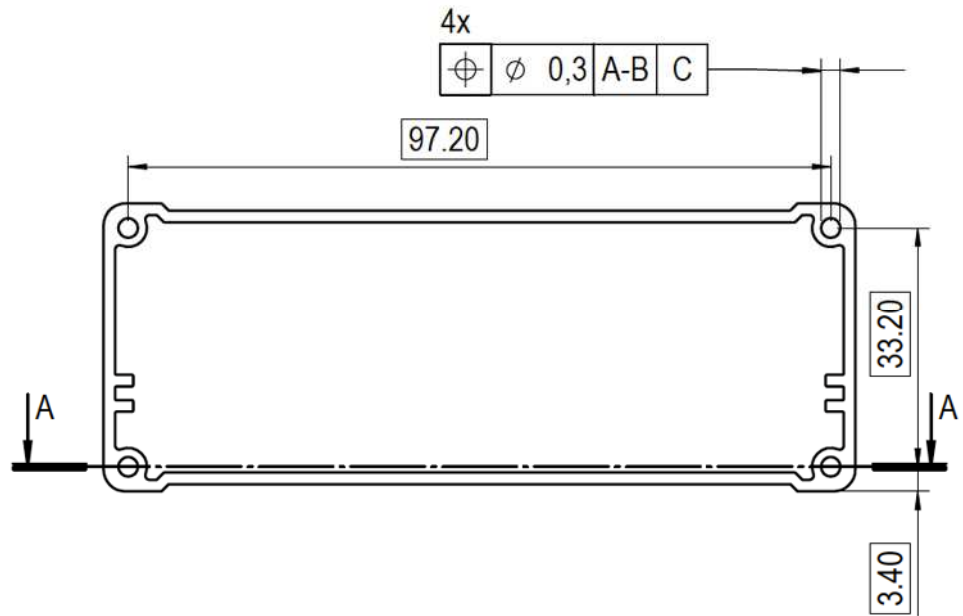

Figure 9-2.
Device Capsule End View.

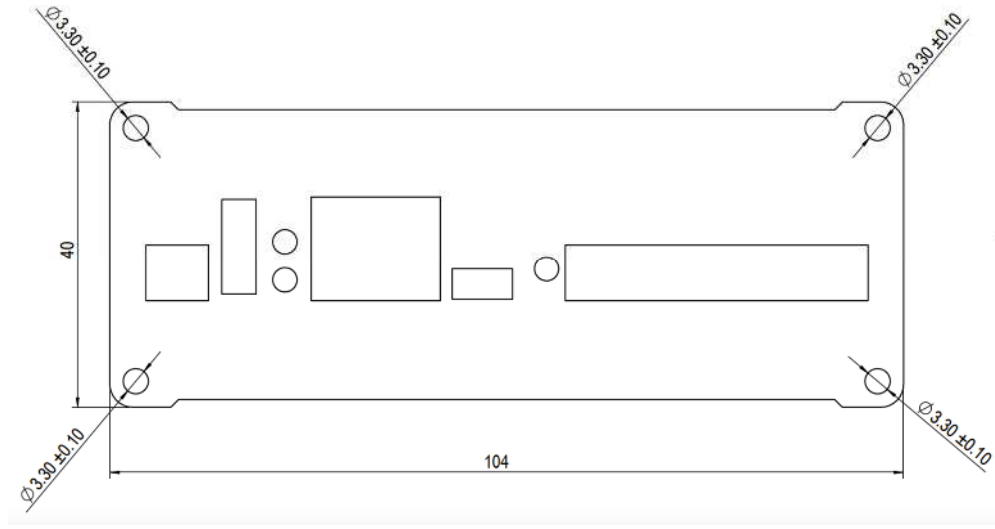

Figure 9-3.
Top Endcap.

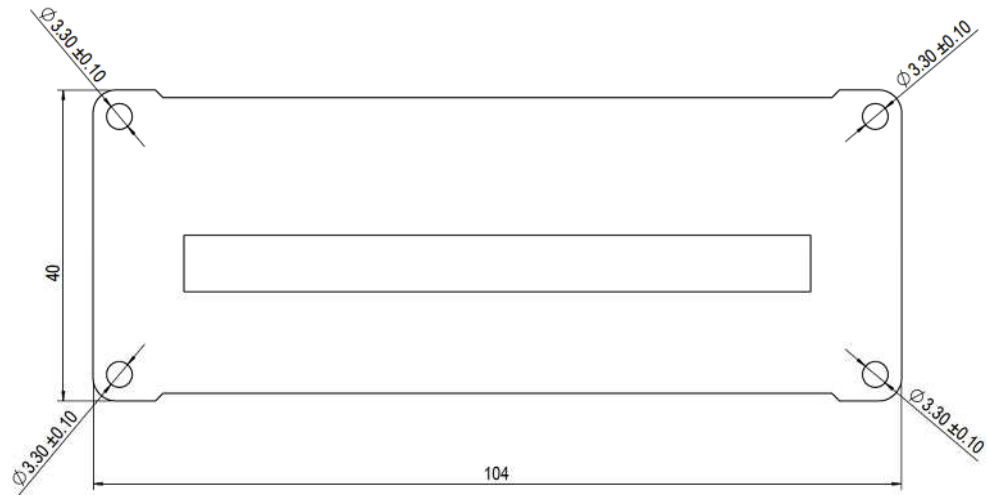

Figure 9-4.
Bottom Endcap.

Appendix A – Limited Warranty

SKF – Limited Warranty

WARRANTY

Subject to the terms and conditions contained herein and provided that there is no applicable written agreement between the selling entity in the SKF Group (“SKF”) and the Buyer specifically covering the sale of the Products (as defined below) that includes a product warranty, SKF warrants to the Buyer that for the warranty period indicated below the products sold by SKF that are listed below (the “Products”), when properly installed, maintained and operated, will be free from defects in material and workmanship and shall be fit for the ordinary purposes for which the Products are designed.

BUYER’S LIMITED REMEDIES

This limited warranty defines SKF’s sole and exclusive liability and Buyer’s sole and exclusive remedy for any claim arising out of, or related to, any alleged deficiency in any Product sold by SKF, even if such claim is based on tort (including negligence or strict liability), breach of contract, or any other legal theory. If the Product does not conform to this limited warranty, Buyer must notify SKF or SKF’s authorized service representative within thirty (30) days of discovery of the nonconformity; provided, however, that SKF shall not be liable for any claim for which notice is received by SKF more than thirty (30) days following the expiration of the applicable warranty period for the Product. Upon receipt of timely notification from

Buyer, SKF may, at its sole option, modify, repair, replace the Product, or reimburse Buyer for any payment made by Buyer to SKF for the purchase price of the Product, with such reimbursement being pro-rated over the warranty period.

WARRANTY PERIOD

Except as expressly provided below, the warranty period for each Product shall commence on the date the Product is shipped by SKF to Buyer.

90-DAY WARRANTY

Products warranted for ninety (90) days by SKF are as follows: cable assemblies, MARLIN QuickConnect (MQC), magnetic temperature probes, and all refurbished equipment.

ONE-YEAR WARRANTY

Products warranted for one (1) year by SKF are as follows: all Microlog products and accessories, all Microlog Inspector applications including hand-held computers, all MARLIN data managers (MDM), all MARLIN Condition Detectors (MCD), all Wireless Machine Condition Detectors (WMCD), all Multilog Condition Monitoring Units (CMU, TMU), Multilog Local Monitoring Units (LMU), all Multilog Wireless Monitoring Units (WMx), Multilog On-line System Wireless Vibration Transmitter ISA100, all Wireless Monitoring Systems V/T, all Vibration PenPlus, all Machine Condition Advisors (MCA), all Machine Condition Indicators (MCI), all transmitters, all Monitor Interface Modules (MIM), all Machine Condition Transmitters (MCT), all MicroVibes

and Custom Products with the prefix of CMCP (with the exception of any consumable or expendable items), Shaft Alignment Systems TKSA 60 and TKSA 80 including hand-held computer, measuring devices and accessories.

TWO-YEAR WARRANTY

Products warranted for two (2) years by SKF are as follows: all standard Eddy Probes, Eddy Probe Drivers, and Eddy Probe Extension Cables, all Multilog On-line Systems (IMx), all Wireless Machine Condition Sensors, and all M800A and VM600 Machinery Monitoring Systems.

For all On-line Systems (as defined below) that have satisfied Criteria 1 and 2 below, the warranty period shall be either thirty (30) months from the date the On-line System is shipped by SKF to Buyer, two (2) years from the date the On-line System is installed and commissioned by SKF, or two (2) years from the date on which the installation of the On-line System has been audited and commissioned by SKF or its authorized service representative, whichever period ends first.

Criteria 1.

Devices used with a Multilog On-line System (IMx), Multilog Condition Monitoring Unit (CMU), Multilog Local Monitoring Unit (LMU), including, but not limited to, the sensing device, the interconnect cabling, junction boxes, if any, and the communications interface, must consist only of SKF-supplied or SKF-approved devices and/or components. The computer provided by Buyer must meet the requirements stipulated by SKF.

Criteria 2.

SKF or its authorized service representative has installed the On-line System or has audited the installation and commissioned the On-line System.

“On-line Systems” are defined as systems consisting of Multilog On-line System (IMx), Multilog Condition Monitoring Unit(s) (CMU), Multilog Local Monitoring Unit(s) (LMU), and any sensing or input devices, the interconnect cabling between the sensing or input devices and the Multilog On-line System (IMx), Multilog Condition Monitoring Unit(s) (CMU), Multilog Local Monitoring Unit(s) (LMU), and the cabling between the Multilog On-line System (IMx), Multilog Condition Monitoring Unit (CMU), Multilog Local Monitoring Unit (LMU) and the proprietary SKF communications interface with the host computer.

FIVE-YEAR WARRANTY

Products warranted for five (5) years by SKF are as follows: special seismic sensors.

LIMITED LIFETIME WARRANTY

Products covered under this Limited Lifetime Warranty (as set forth below) are as follows: standard seismic sensors of the CMSS 2XXX and CMSS 7XX series (accelerometers and velocity transducers) as marked and published in the SKF Vibration Sensor Catalogue.

(A) Subject to the terms herein, SKF will provide a “Limited Lifetime Warranty” for the products specified above sold by SKF after April 15, 2014. Under the

- Limited Lifetime Warranty, those products shall, at the time of shipment, be free from defects in material and workmanship. If any of these products fail to meet the terms of this Limited Lifetime Warranty during the life of such products, SKF, in its sole discretion, will repair, replace or exchange the products for the same model if the necessary components for the products are still available to SKF on a commercially reasonable basis. SKF will not provide a Limited Lifetime Warranty on products damaged by accident, abuse, misuse, neglect, improper installation, problems with electrical power, natural disaster, or by any unauthorized disassembly, repair or modification.
- (B) Upon receipt of any product covered by the Limited Lifetime Warranty, SKF will pay all shipping charges to send the repaired, replaced or exchanged product to the original point of shipment. SKF reserves the right to decline repair or replacement if no fault is found in the product.
- (C) For any warranty claim, the original Buyer must provide SKF with the applicable model and serial numbers, the date of purchase, the nature of the problem, and proof of purchase. SKF, in its sole discretion, will determine if the Buyer must return the product covered under this warranty to SKF.
- (D) The express warranty set forth in the Limited Lifetime Warranty is in lieu of and excludes any and all other warranties express or implied, including, but not limited to, the implied warranties of merchantability and fitness for a particular purpose.
- (E) SKF's sole obligations under this Limited Lifetime Warranty are set forth in paragraphs (A) and (B), and SKF's liability under this Limited Lifetime Warranty shall not exceed the purchase price of the product, plus any shipping and handling charges that SKF may be obligated to pay pursuant to paragraph (B).
- (F) **IN NO EVENT SHALL SKF BE LIABLE OR OBLIGATED TO THE BUYER OR ANY OTHER PERSON FOR SPECIAL, EXEMPLARY, PUNITIVE, INCIDENTAL, DIRECT, INDIRECT, GENERAL OR CONSEQUENTIAL DAMAGES (INCLUDING, BY WAY OF EXAMPLE ONLY, LOST PROFITS OR SAVINGS, LOSS OF BUSINESS OR LOSS OF USE) OR ANY OTHER LOSS, COST OR EXPENSE IN CONNECTION WITH THE PRODUCTS REGARDLESS OF WHETHER OR NOT ANY OF THE FOREGOING WERE FORESEEABLE OR THAT SKF WAS ADVISED AS TO THE POSSIBILITY OF SUCH DAMAGES, LOSS, COST, OR EXPENSE.**
- (G) The Limited Lifetime Warranty applies solely to the original Buyer and is non-transferrable.
- OTHER SKF PRODUCTS**
- Any SKF product supplied hereunder but not covered by this limited warranty shall be either covered by the applicable SKF limited warranty then in place for such product or, if

no such warranty exists, shall be covered by the 90-day warranty stated above.

THIRD PARTY PRODUCT WARRANTIES

For any third-party products sold to Buyer by SKF, SKF will transfer to Buyer any warranties made by the applicable third party product vendor to the extent such warranties are transferable.

CONDITIONS

As a condition to SKF's warranty obligations hereunder and if requested or authorized in writing by SKF, Buyer shall forward to SKF any Product claimed by Buyer as being defective. Buyer shall prepay all transportation charges to SKF's factory or authorized service centre. SKF will bear the cost of shipping any replacement Products to Buyer. Buyer agrees to pay SKF's invoice for the then-current price of any replacement Product furnished to Buyer by SKF, if the Product that was replaced is later determined by SKF to conform to this limited warranty.

SKF shall not be obligated under this limited warranty or otherwise for normal wear and tear or for any Product which, following shipment and any installation by SKF (if required by the contract with the Buyer), has, in SKF's sole judgment, been subjected to accident, abuse, misapplication, improper mounting or remounting, improper lubrication, improper repair or alteration, or maintenance, neglect, excessive operating conditions or for defects caused by or attributable to the Buyer, including without limitation Buyer's failure to comply with any written instructions provided to Buyer by SKF.

SKF shall be free to conduct such tests, investigations and analysis of the Products returned to SKF, as it deems reasonable and proper in the exercise of its sole judgment. As a further condition to SKF's obligations hereunder, Buyer shall offer its reasonable cooperation to SKF in the course of SKF's review of any warranty claim, including, by way of example only, Buyer's providing to SKF any and all information as to service, operating history, mounting, wiring, or re-lubrication of the Product which is the subject of the Buyer's warranty claim.

EXCEPT WARRANTY OF TITLE AND FOR THE WARRANTIES EXPRESSLY SET FORTH IN HEREIN, IT IS UNDERSTOOD AND AGREED THAT:

- (A) SKF MAKES NO OTHER WARRANTY, REPRESENTATION OR INDEMNIFICATION, EITHER EXPRESS OR IMPLIED, INCLUDING WITHOUT LIMITATION ANY IMPLIED WARRANTY OF MERCHANTABILITY, FITNESS FOR A PARTICULAR PURPOSE, OR NON-INFRINGEMENT;**
- (B) IN NO EVENT SHALL SKF BE LIABLE OR OBLIGATED FOR SPECIAL, EXEMPLARY, PUNITIVE, INCIDENTAL, DIRECT, INDIRECT, GENERAL OR CONSEQUENTIAL DAMAGES (INCLUDING, BY WAY OF EXAMPLE ONLY, LOST PROFITS OR SAVINGS, LOSS OF BUSINESS OR LOSS OF USE) OR ANY OTHER LOSS, COST OR EXPENSE IN CONNECTION WITH THE PRODUCTS AND RELATED SERVICES, IF ANY, PROVIDED BY SKF, AND THIS DISCLAIMER SHALL EXTEND AS WELL TO ANY LIABILITY FOR NON-**

PERFORMANCE CAUSED BY SKF'S GROSS OR ORDINARY NEGLIGENCE, AND IN ALL CASES REGARDLESS OF WHETHER OR NOT ANY OF THE FOREGOING WERE FORESEEABLE OR THAT SKF WAS ADVISED AS TO THE POSSIBILITY OF SUCH DAMAGES, LOSS, COST, OR EXPENSE; AND

- (C) NO PERSON HAS BEEN AUTHORIZED BY SKF TO MAKE ANY FURTHER OR CONTRARY INDEMNITIES, REPRESENTATIONS OR WARRANTIES ON BEHALF OF SKF. THE FOREGOING LIMITATIONS AND DISCLAIMERS OF LIABILITY SHALL BE MADE APPLICABLE TO THE SALE OF ANY PRODUCT BY SKF TO THE**

FURTHEST EXTENT PERMITTED BY APPLICABLE LAW.

The exclusive remedies provided in this limited warranty shall not be deemed to have failed of their essential purpose so long as SKF is willing and able to perform to the extent and in the manner prescribed in this limited warranty.

® SKF, MICROLOG and MULTILOG are registered trademarks of the SKF Group.

CM-F0001 EN
Revision Y, March 2017

Index

A

accelerometer power supply 6-1
accuracy amplitude 6-2
accuracy frequency 6-3
altitude 6-1
analogue input range 6-1
analogue inputs 6-1
analogue measurement 6-2

B

Bluetooth 2-7, 6-3

C

cable glands 2-4
cable type 2-3, 2-4
calibration 6-4
CE certified 6-4
communication cable 2-5
cress-talk rejection 6-2

D

digital inputs 6-2
dimensions 6-1
drawings 9-1
dynamic range 6-2

E

electical waste 5-2
ethernet 6-3
ethernet cable 2-3, 2-5
ethernet LEDs 2-6

F

frequency range 6-2, 6-3

H

hardware maintenance 4-2
help 7-1
HEX rotary switches 3-8

I

impedance 6-1
important messages 1-1
IMx Manager 3-8
IMx-8 1-2
IMx-8 time 3-10
IMx-8 unit 1-4
initiating IMx-8 1-4
installation 2-2
installation plan 2-3
interface 6-3
IP number 3-8
IP rating 6-1
ISO 6-4

L

LED indicators 1-5

M

maintenance 4-2
measurement category 6-1
modbus 3-6

N

network 2-3, 3-8
network configuration 3-8

O

ODBC 1-2
On-line Device Configurator 3-8
outputs 6-2

P

pollution degree 6-1

port number 3-8
power consumption 6-1
power supply 6-1, 6-2
problems 7-1
pulse counting 6-3

Q

quality control 6-4

R

recycle 5-2
relay driver output 6-2
RJ45 2-6
rotary switches 3-8
RS232 6-3
RS485 3-6

S

scenario 2-3
sensor cable type 2-3
sensor cables 2-3
set time 3-10
signal processing 6-3
signal to noise ratio 6-2
simultaneous sampling 6-2
SKF @plitude Observer Monitor Service 1-2
SKF Multilog On-line System 1-2
special care 1-1
supply cable 2-4
supply cable type 2-4
symptoms 7-1
system overview 1-2

T

TCP/IP address 3-8
temperature 6-1
time synchroniazation 3-10
troubleshooting 7-1

U

unit configuration 2-1
unit ID 3-8

V,W

weight 6-1