

# R11-F

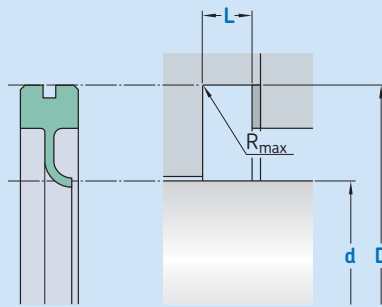

Ordering dimensions in **blue**

Surface roughness	$R_{tmax}$	$R_a$
<b>Sliding surface</b>	$\leq 2 \mu m$	0,05–0,3 $\mu m$
<b>Bottom of groove</b>	$\leq 6,3 \mu m$	$\leq 1,6 \mu m$
<b>Groove face</b>	$\leq 15 \mu m$	$\leq 3 \mu m$

Bearing area: 50–95% and a cutting depth of 0,5  $R_z$  based on  $C_{ref} = 0\%$

## Standard dimensions

d	f8	D	$L_{min}$	$R_{max}$
over	incl.	H10		
mm				
<b>50</b>	<b>100</b>	d + 20	4 -0,05	0,4
<b>100</b>	<b>150</b>	d + 25	5 -0,05	0,4
<b>150</b>		d + 30	6 -0,10	0,4

## Ordering example

Profile  
d x D x L [mm]  
Sealing material

Rotary seal R11-F  
100 x 120 x 4  
SKF Ecoflon 4

## Operating parameters

Material Seal	Temperature		Speed <sup>1)</sup>	Pressure
	from	to	max	max
–	°C		m/s	bar (MPa)
■ SKF Ecoflon 2				
■ SKF Ecoflon 3	–200	+260	20	5 (0,5)
■ SKF Ecoflon 4				

IMPORTANT NOTE: The stated operating conditions represent general indications. It is recommended not to use all maximum values simultaneously.

<sup>1)</sup> Surface speed limit values are valid only in the presence of a lubrication film.