

DK02-P

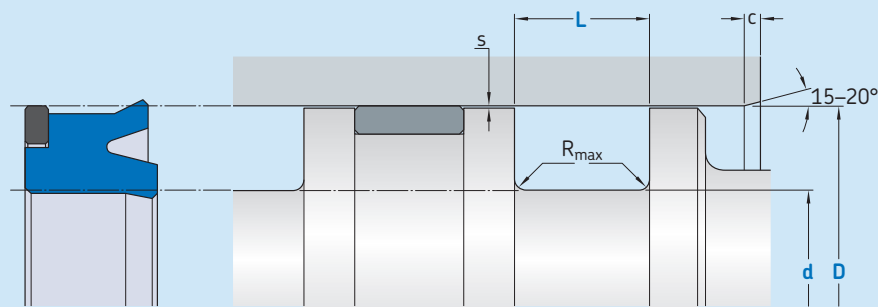

Ordering dimensions in **blue**

Surface roughness	R_{tmax}	R_a
Sliding surface	$\leq 2,5 \mu m$	$0,05-0,2 \mu m$
Bottom of groove	$\leq 6,3 \mu m$	$\leq 1,6 \mu m$
Groove face	$\leq 15 \mu m$	$\leq 3 \mu m$

Bearing area: 50–95% and a cutting depth of $0,5 R_z$ based on $C_{ref} = 0\%$

Standard dimensions						Maximal radial extrusion gap			
D	d	L	R_{max}	c	$s^{1)}$				
H9	incl.	$+0,2$				20 bar	100 bar	400 bar	700 bar
mm						mm			
13	25	D-8	6,0	0,4	3,5	0,80	0,80	0,30	0,04
25	50	D-10	7,0	0,4	4,0	1,00	1,00	0,37	0,04
50	75	D-12	8,0	0,4	4,5	1,25	1,24	0,42	0,05
75	150	D-15	10,0	0,4	5,0	1,50	1,47	0,46	0,05
150	200	D-20	12,0	0,4	6,0	2,00	1,77	0,54	0,06

¹⁾ Extrusion gap values shown above are valid for a temperature of 70 °C, higher temperatures require lower values.

Ordering example

Profile
D x d x L [mm]
Sealing material / Backup ring

Piston seal DK02-P
100 x 85 x 10
ECOPUR DD / SKF Ecotal

Operating parameters

Material Seal	Back-up ring	Temperature		Speed ¹⁾	Pressure ²⁾
		from	to	max	max
–		°C		m/s	bar(MPa)
■ ECOPUR DD	■ SKF Ecotal	–30	+100	0,5	700 (70)

IMPORTANT NOTE: The stated operating conditions represent general indications. It is recommended not to use all maximum values simultaneously.

¹⁾ Surface speed limit values are valid only in the presence of a lubrication film.

²⁾ Pressure ratings depend on the size of the extrusion gap.