

Easylube Automatic Lubricator

Description

IMPORTANT: Refer to the **Troubleshooting Chart** for installation hints.

Automatic lubricator model 1746-151 automatically supplies a single lubrication point with oil or grease (up to grade 2) electromechanically. This model lubricator:

- contains a cup that is designed to be refilled with the use of accessories.
- is powered and activated with the installation of its battery pack.

Dispense Period and Lubrication Amount

The lubricator can be set to any of 12 (represents months) dispensing periods. It is empty at the end of the chosen setting. Each monthly setting dispenses the same amount of lubricant per cycle, but at a different frequency. See **Table 1**.

Dispense Period	Time Span Between Cycles	Amount/Cycle		Amount/Day		Amount/Week		Amount/Month	
		Oz	ml	Oz	ml	Oz	ml	Oz	ml
Month	Hrs								
1	2	0.014	0.417	0.17	5	1.18	35	5.1	150
2	4			0.08	2.5	0.59	17.5	2.54	75
3	6			0.06	1.67	0.39	11.67	1.7	50
4	8			0.04	1.25	0.30	8.75	1.27	37.5
5	10			0.033	1.00	0.24	7.00	1.01	30
6	12			0.028	0.83	0.20	5.83	0.84	25
7	14			0.024	0.71	0.17	5.00	0.72	21.43
8	16			0.021	0.63	0.15	4.38	0.63	18.75
9	18			0.019	0.56	0.13	3.89	0.56	16.67
10	20			0.017	0.50	0.12	3.50	0.51	15
11	22			0.015	0.45	0.11	3.18	0.46	13.64
12	24			0.014	0.42	0.10	2.92	0.42	12.5

Table 1 Lubricator Dispense Period Compared with Frequency

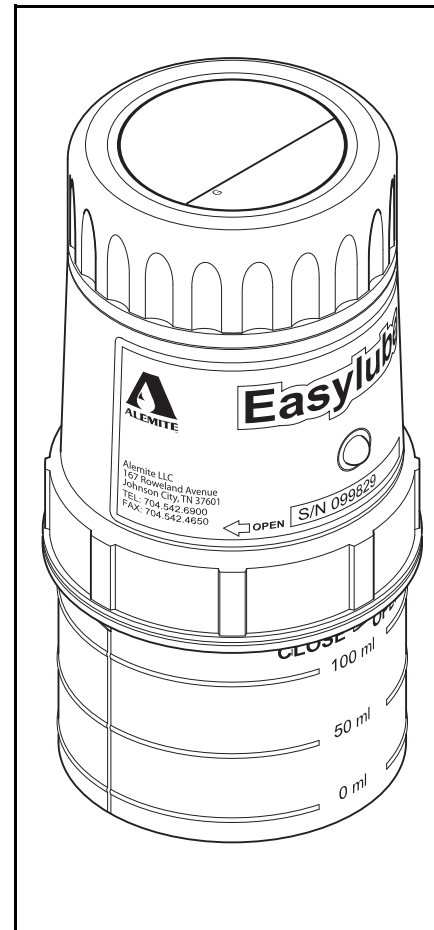

Figure 1 Easylube Lubricator Model 1746-151 [shroud not shown]

UL Approved	Material Outlet	Capacity		Pressure Range		Operating Temperature Range		Dimensions (Length x Diameter)		Lithium Battery
		Ounces	ml (cm ³)	psi	bar	° F	° C	Inches	Cm	
Class I Division 2 Group B, C, D Class II Division 2 Group F, G	1/2 " PT (m)	5.1	150	75 - 150	5 - 10	-4 to 140	-20 to 60	6 x 3.3	15.2 x 8.4	6 Volt

Table 2 Easylube Lubricator Model 1746-151 Specifications

Alemite, LLC
167 Roweland Drive, Johnson City, Tennessee 37601
www.alemite.com

Copyright © 2006 by Alemite, LLC

This document contains confidential information that is the property of Alemite, LLC and is not to be copied, used, or disclosed to others without express written permission.

SER 1746-151
Revision (7-13)

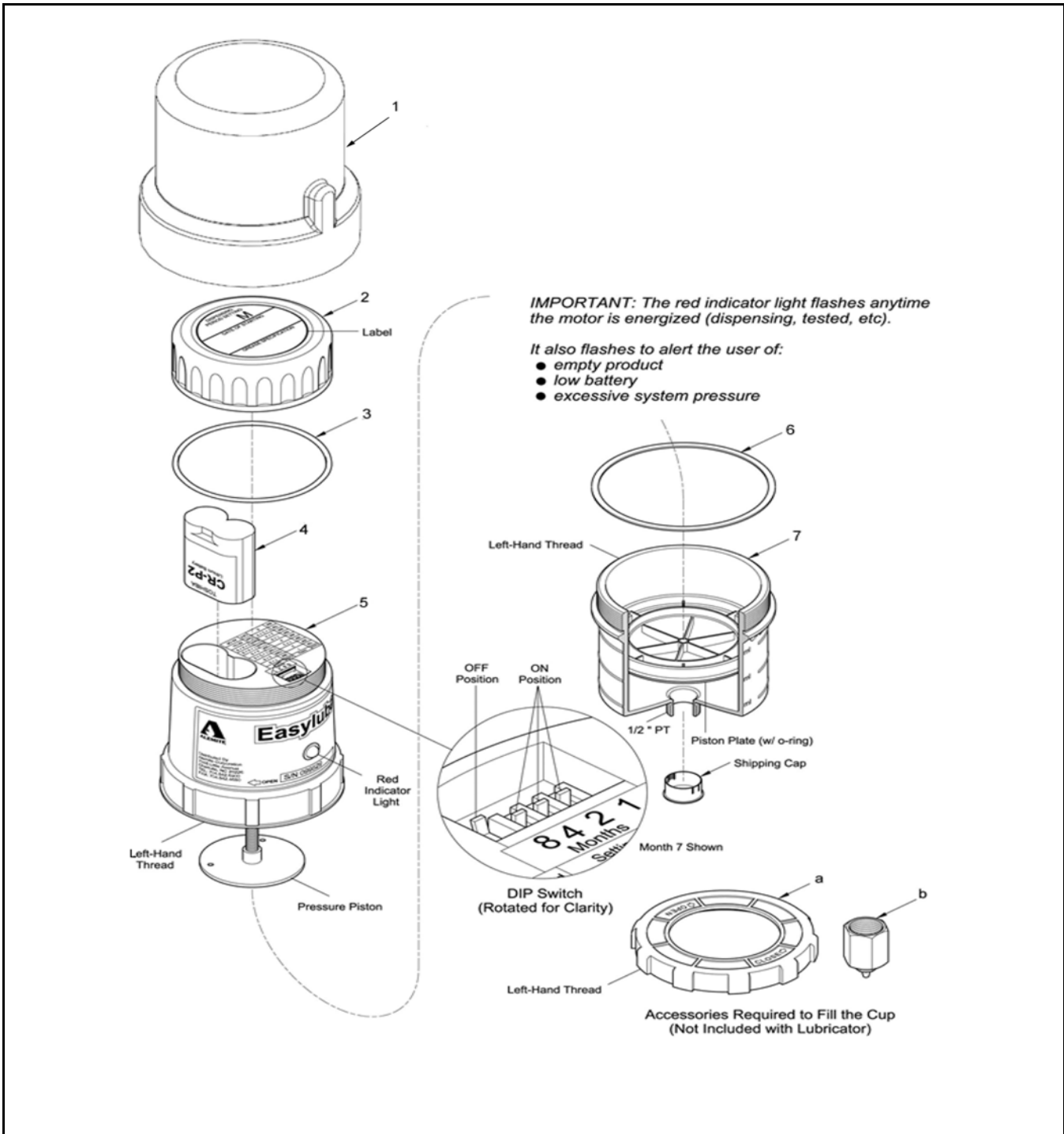

Item No.	Part No.	Description	Qty	Item No.	Part No.	Description	Qty
1		Shroud	1	6		Gasket	
2		Cover (w/ Label)	1	7	339588	Cup, (includes Piston PLate)	1
3		O-Ring	1	a	339589	Cover, Refill Positioning	1
4	339603	Battery, Lithium (6 Volt)	1	b	339590	Nipple, Refill, 1/2" PT (f)	1
5		Body Assembly	1				

Legend:

Part numbers left blank are not available separately

Figure 2 EasyLube Lubricator Model 1746-151 - Exploded View

Preparation / Maintenance

NOTE: Refer to **Figure 2** for component identification on all procedures.

Fill the Cup

1. Remove the lubricator from its system connection or remove the Shipping Plug from Cup (7).
2. Screw Nipple (b) onto the outlet of the Cup.
3. Unscrew the Cup from Body Assembly (5).

IMPORTANT: Do not attempt to fill the Cup manually. Air can become trapped within the grease.

4. Screw Positioning Cover (a) onto the Cup.



WARNING

Do not exceed the maximum pressure rating of the lubricator [75 psi (5.2 bar)]. Personal injury can occur.

With the use of a control valve or gun:

5. Fill the Cup with lubricant until the Piston Plate contacts the Positioning Cover.
6. Unscrew the Positioning Cover from the Cup.

Position the Pressure Plate

7. Facing the bottom of the Body Assembly, turn the Pressure Piston clockwise until it seats.
8. Next, rotate the Pressure Piston counterclockwise with a 3/4 turn.
9. Screw the Cup into the Body Assembly securely.

Dispense Period in Months	DIP Switch Levers On	Battery Life in Days *	Dispense Period in Months	DIP Switch Levers On	Battery Life in Days *	Dispense Period in Months	DIP Switch Levers On	Battery Life in Days *
1	1	87	5	1 and 4	194	9	1 and 8	300
2	2	114	6	2 and 4	221	10	2 and 8	328
3	1 and 2	140	7	1 and 2 and 4	245	11	1 and 2 and 8	351
4	4	168	8	8	277	12	4 and 8	382
Back **	1 + 4 + 8 and 2 + 4 + 8		Test ***	All On		OFF	All Off	

NOTE: Refer to **Figure 2** for location of DIP switch levers.

* The number of days is approximate and is based on a system pressure of 45 psi (3 bar).

** **Back** causes the red indicator light to flash and enables the motor to operate the Pressure Piston counterclockwise (away from Pressure Plate).

*** **Test** causes the red indicator light to flash and enables the motor to operate the Pressure Piston clockwise (toward Pressure Plate).

Install / Replace Battery Pack

Replace the Battery Pack:

- at the end of each dispensing period
- once the red indicator light begins to flash
- anytime the Battery Pack's voltage is below 6V

IMPORTANT: The lubricator maintains memory and can remain installed during this procedure.

10. Unscrew Cover (1) from Body Assembly (5).



WARNING

Always recycle or dispose of the Battery Pack properly.

Do not burn or puncture the batteries. Toxic materials may be emitted which can cause personal injury.

11. Remove Battery Pack (4) from the Body as required.
 - Discard the Battery Pack.

The removal of the Battery Pack turns off the lubricator.

Set / Change the Dispense Period

12. Make sure the Battery Pack is removed from the Body.
13. Locate the DIP (Dual Inline Package) Switch in the Body Assembly.
14. Set the levers on the switch to correspond to the time period required. See **Table 3**.
 - Use a ball point pen or similar tool (small screwdriver).

Table 3 Lubricator Dispense Period Compared with DIP Switch Lever Positions and Battery Life

Start the Lubricator

CAUTION

Avoid touching the contact surfaces of the new batteries. Skin oils can cause deterioration. Clean any suspect battery with alcohol prior to installation.

15. Install the Battery Pack into the Body slowly.

The red indicator light on the Body illuminates for 5 seconds and then goes out. This indicates the lubricator has been started correctly.

16. Screw the Cover onto the Body securely.

Identification

17. On the Cover's label record the:
- dispensing period setting
 - type of lubricant
 - date of installation

Installation

WARNING



Do not discard shroud. Installation of unit without shroud may result in moisture damage to the lubricator and voids the warranty.

Whenever possible, install oil-filled lubricators at a level below the lubrication point.

If this installation is not viable, then the use of an oil throttle, or check valve, within the system is required to prevent drainage. See the bolded items in Table 5.

This Lubricator is suitable for outside applications.

IMPORTANT: Lubricator must not be installed upside down, horizontally or at more than 15° off the vertical.

Direct Mount

IMPORTANT: Make sure the existing lubricant in the bearing is compatible with the lubricant in the cup.

1. Remove Nipple (b) from Cup (7).
2. Screw the lubricator (in any position) into the bearing.
 - Do not overtighten.

Use a reducer or adapter as required.

Remote Mount

IMPORTANT: Do not install the lubricator further than 15 feet (4.6 m) from the lubrication point. Keep the number of bends and the length of line to a minimum.

If a direct connection is not feasible, tubing, hose, or pipe can be used [with an optional mounting bracket (see Table 5)]. The size of the line is dictated by its type. See Table 4.

The pressure rating on any system component must be a minimum of 150 psi (10.3 bar).

IMPORTANT: Should system pressure be greater than 75 psi (5.2 bar) the lubricator's:

- motor is enabled to operate the Pressure Piston counterclockwise (relieve pressure from the Pressure Plate)
- red indicator light begins to flash

Should this occur, the system may require cleaning and/or the dispensing period may be too frequent.

Tubing	Hose	Pipe
5/16 " OD	3/8 " ID	1/4 "

Table 4 Tubing, Hose, and Pipe Size

Accessories

Part No.	Description	Part No.	Description
339592	Adapter, Straight, 1/2 " (f) x 1/8 " (m)	339591	Adapter, 45°, 1/2 " (f) x 1/8 " (m)
339594	Adapter, Straight, 1/2 " (f) x 1/4 " (m)	339593	Adapter, 45°, 1/2 " (f) x 1/4 " (m)
339596	Adapter, Straight, 1/2 " (f) x 3/8 " (m)	339595	Adapter, 45°, 1/2 " (f) x 3/8 " (m)
339600	Adapter, Straight, 1/2 " (f) x 8 mm (m)	339599	Adapter, 45°, 1/2 " (f) x 8 mm (m)
339602	Adapter, Straight, 1/2 " (f) x 10 mm (m)	339601	Adapter, 45°, 1/2 " (f) x 10 mm (m)
387390	Oil Throttle, 1/8 " (f) x 1/8 " (m)	339598	Bracket, Mounting [w/ 1/2 " PT (f) connector for 6 mm (m) OD copper tube] *
387391	Check Valve, 1/4 " (f) x 1/4 " (m)		

Either of the items listed in **bold** (with Adapter) are required for an oil-filled lubricator when its lubrication point is above the lubricator
 * Use when the ambient temperature within the environment of the bearing exceeds 122 ° F (50 ° C)

Table 5 *Easylube Lubricator Accessories*

Troubleshooting Chart

Indications	Possible Problems	Solution
Grease separates.	Lubricator lines not completely flushed.	Flush the bearing and all lines completely with the same grease as the lubricator.
Lubricator does not dispense.	<ol style="list-style-type: none"> 1. Weak battery. Warning light can consume battery. 2. Pressure Plate is not in contact with the follower. 3. Ambient temperature too low for the viscosity of the grease. 	<ol style="list-style-type: none"> 1. Verify the output voltage of battery exceeds 6.0 V. Always start the lubricator with a new battery. Operate the lubricator in test mode for 1 minute to ensure proper operation prior to installation. 2. Check the position of the pressure plate to ensure it is in contact with the follower. 3. Change to a lower viscosity grease. For example, change from NLGI #2 to NLGI #1 or #0.
Unable to set DIP switch levers.	Incorrect tool being used.	Move the levers with a ball point pen or a small screwdriver.
Lubricator's red indicator light begins to flash.	<ol style="list-style-type: none"> 1. Battery Low. 2. Lubricator empty. 3. Back pressure exceeds 75 psi (5.2 bar). 	<ol style="list-style-type: none"> 1. Test battery voltage with volt meter. 2. Fill the cup. 3. Use test apparatus to measure back pressure.

Changes Since Last Printing

Added Shroud

