

# SKF Dynamic Motor Link EP1000

Safely and quickly connect SKF EXP4000 Dynamic Motor Analyzers to motors – from the outside of a motor control cabinet



Safety is a critical consideration among motor maintenance professionals going about their routine jobs. The potential for arc flash hazards makes dynamic (online) motor testing in a motor control cabinet (MCC) dangerous, if not prohibitive. The personal protection equipment required to safely enter these flash zones is cumbersome, making the task of motor monitoring difficult.

The SKF EP1000 dynamic motor link was designed to enable convenient monitoring of motors and the machine systems they are part of. Combined with the EP1000's safety benefits, it is the ideal solution for safe, effective online motor monitoring.

Once permanently installed in an MCC, the EP1000 does not require motor maintenance personnel to open the cabinet again for monitoring purposes. A user simply attaches a cable from the SKF Dynamic Motor Analyzer – EXP4000 to the permanently-installed exterior port on the MCC door. Once attached, the

connection allows the EXP4000's Surveyor EXP software to automatically load the test and data for the motor being monitored from the database.

A user can easily perform the necessary measurements, then disconnect the EXP4000 and leave the zone with minimal exposure to the dangers that lie within an MCC. Peak voltage during operation is 5 V or less, and the accessory is passive (un-powered) when the EXP4000 is not attached. The EP1000 can be directly connected to motors at voltages of up to 1000 V. It can also test higher-voltage motors via MCC PTs and CTs .

EXP4000 users obtain reliable, consistent results with the EP1000. Since there is only a single connection, the risk of any misconnections is eliminated. A user can gather electrical data without interruption of the motor operation. Typical data acquisition time is one to four minutes. This makes monitoring of critical equipment quick, reliable, safe and easy.



*The SKF Dynamic Motor Analyzer - EXP4000 connects easily and safely to an MCC via the EP1000 port mounted on the cabinet door*



*An EP1000 mounted inside a motor control cabinet with proper connections*

## Specifications

### Ports

Voltage Input Port	4-pin Wago terminal block, three voltages up to 1 000 V and one ground
Current Input Port	6-pin Phoenix contact terminal block for three bi-directional CT $\pm 5$ V AC signal DB25
Mixed Signal Output Port	

### Current transformers

Primary ratings	5 A, 10 A, 50 A, 200 A, 600 A, 1 000 A, 1 500 A, 2 000 A, 3 000 A (solid and split core available)
Secondary ratings	Voltage output, $\pm 5$ V AC peak instantaneous
Isolation	600 V hipot tested
Signal bus	Twisted pair wire. Differential signal.

### EP1000/MCC cable

Length	60 in.
Installation	From EP box to MCC front panel internal to MCC
Ports	DC25 to DB25 panel mount connector

### EXP4000/EP1000 cable

One cable is required per EXP4000 for connections to EP1000

### Physical characteristics

Weight	0.2 lbs (without CTs)
Dimensions	5.75 x 5.25 x 1.6 in.

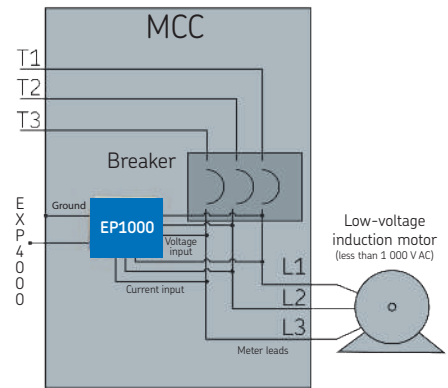

### Notes:

1. For medium- and high-voltage motors, voltage inputs must be connected to the PTs
2. A detailed EP1000 installation manual provides specs that include mechanical dimensions, electrical connection details and templates for installation.



Examples of CT connections to the secondaries of the protection CTs.

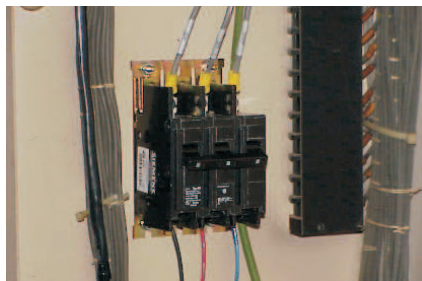
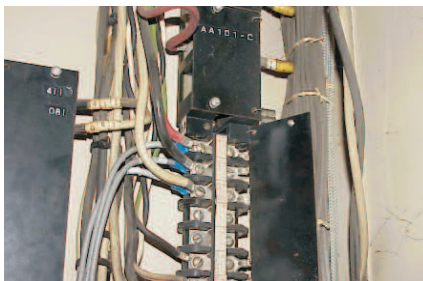

Examples of voltage connections to PT outputs for medium and high voltage motors.

[www.skf.com/emcm](http://www.skf.com/emcm)

SKF USA, Inc.  
Electric Motor Condition Monitoring  
4812 McMurry Avenue, Fort Collins, CO 80525  
Tel: 970-282-1200 salesEMCM@skf.com

© SKF is a registered trademark of the SKF Group.

© SKF Group 2016.

The contents of this publication are the copyright of the publisher and may not be reproduced (even extracts) unless prior written permission is granted. Every care has been taken to ensure the accuracy of the information contained in this publication but no liability can be accepted for any loss or damage whether direct, indirect or consequential arising out of the use of the information contained herein.

PUB CM/P2 16844 EN · September 2016