

Electrically operated oil pump EOP2

Assembly instructions
following machinery directive 2006/42/EC

EN



951-171-012-EN

2017/10/25

Version 03



EC Declaration of incorporation following machinery directive 2006/42/EC, annex II, part 1 B

The manufacturer, SKF Lubrication Systems Germany GmbH, Walldorf Facilities, Heinrich-Hertz-Str. 2-8, DE - 69190 Walldorf, hereby declares that the partly completed machinery

Designation: Pump to supply lubricating oil within a chain lubrication system

Type: EOP2

Part number: EOP2- xx-xx-x-x+xxx

Year of construction: See type identification plate

complies with the following basic safety and health requirements of the EC machinery directive 2006/42/EC at the time when first being launched in the market.

1.1.2 · 1.1.3 · 1.3.2 · 1.3.4 · 1.5.1 · 1.5.6 · 1.5.8 · 1.5.9 · 1.6.1 · 1.7.1 · 1.7.3 · 1.7.4

The special technical documents were prepared following Annex VII part B of this directive. Upon justifiable request, these special technical documents can be forwarded electronically to the respective national authorities. The person empowered to assemble the technical documentation on behalf of the manufacturer is the head of standardization, See manufacturer's address.

Furthermore, the following directives and harmonized standards were applied in the respective applicable areas:

2011/65/EU

RoHS II

2014/30/EU

Electromagnetic compatibility | Industry

Standard	Edition	Standard	Edition
EN ISO 12100	2011	EN 82079-1	2013
EN 809	2012	EN 61000-6-3	2012
EN 60204-1	2007		

The partly completed machinery must not be put into service until the final machinery into which it is to be incorporated has been declared in conformity with the provisions of machinery directive 2006/42/EC and any other applicable directives.
Walldorf, April 20, 2016

Jürgen Kreuzkämper
Manager R&D Germany
SKF Lubrication Business Unit



Stefan Schürmann
Manager R&D Hockenheim/Walldorf
SKF Lubrication Business Unit



Legal disclosure

Manufacturer

SKF Lubrication Systems Germany GmbH

Manufacturer's facilities

Head Office

Walldorf Facilities

Heinrich-Hertz-Str. 2-8
69190 Walldorf

Germany

Phone +49 (0) 6227 33-0

Fax: +49 (0) 6227 33-259

Berlin Facilities

Motzener Straße 35/37

12277 Berlin

Germany

Phone +49 (0)30 72002-0

Fax +49 (0)30 72002-111

www.skf.com/lubrication

Hockenheim Facilities

2. Industriestraße 4

68766 Hockenheim

Germany

Phone +49 (0)62 05 27-0

Fax +49 (0)62 05 27-101

E-mail: Lubrication-germany@skf.com

www.skf.com/lubrication

Training courses

In order to provide a maximum of safety and economic viability, SKF carries out detailed training courses. It is recommended that the training courses are attended. For more information please contact the respective SKF Service address.

Copyright

© Copyright SKF

All rights reserved.

Warranty

The instructions do not contain any information on the warranty. This can be found in our general terms and conditions.

Disclaimer

The manufacturer shall not be held responsible for damages caused by:

- non appropriate use
faulty assembly, operation, setting, maintenance, repair, negligence or accidents
- Use of inappropriate lubricants
- Improper or late response to malfunctions
- Unauthorized modifications of the product
- the use of non-original SKF spare parts.

Liability for loss or damage resulting from the use of our products is limited to the maximum purchase price. Liability for consequential damages of whatever kind is excluded.

Table of contents





















1.	Safety instructions	9	3.	Overview, functional description	20
1.1	General safety instructions.....	9	4.	Technical data	23
1.2	General behaviour when handling the product.....	9	4.1	General technical data.....	23
1.3	Intended use.....	9	4.2	Electrics and control unit.....	24
1.4	Foreseeable misuse.....	10	4.3	Type identification code.....	25
1.5	Painting of plastic parts.....	10	5.	Delivery, returns, and storage	26
1.6	Notes related to the CE marking.....	10	5.1	Delivery	26
1.7	Modifications of the product.....	11	5.2	Returns	26
1.8	Inspections prior to delivery	11	5.3	Storage.....	26
1.9	Other applicable documents	11	6.	Installation	27
1.10	Notes related to the type identification plate	11	6.1	General information	27
1.11	Persons authorized to operate the pump	13	6.2	Installation.....	27
1.11.1	Operator.....	13	6.3	Mechanical connection.....	28
1.11.2	Specialist in mechanics.....	13	6.3.1	Minimum assembly dimensions	28
1.11.3	Specialist in electrics	13	6.3.2	Installation bores	29
1.12	Briefing of external technicians	13	6.4	Electrical connection	30
1.13	Provision of personal protective equipment.....	13	7.	Initial start-up	31
1.14	Operation	13	7.1	Fill the pump	31
1.15	Emergency stopping of the pump station	13	7.2	Vent the pump.....	31
1.16	Transport, installation, maintenance, malfunctions, repair, shutdown, disposal.....	14	7.3	Inspections prior to initial activation.....	32
1.17	Initial commissioning / daily start-up	15	7.4	Pump activation	33
1.18	Cleaning	15	7.5	Inspections during the initial activation	33
1.19	Residual risks	16			
2.	Lubricants	18			
2.1	General information	18			
2.2	Selection of lubricants.....	18			
2.3	Material compatibility.....	18			
2.4	Temperature characteristics.....	18			
2.5	Ageing of lubricants.....	18			





8.	Designing an EOS oil system	34		
8.1	Overview, functional description.....	34		
8.2	Technical data of the metering element.....	36		
8.2.1	Output.....	36		
8.2.2	Dimensions of the metering element.....	36		
8.3	Installation.....	37		
8.3.1	General information.....	37		
8.3.2	Place of installation.....	37		
8.3.8	Configuration of the lubrication lines.....	43		
8.3.10	Filling of the oil system.....	45		
8.3.11	Application example:.....	47		
8.4	Troubleshooting.....	48		
9.	Operation	49		
9.1	Operation.....	49		
9.2	Refill lubricant.....	49		
10.	Cleaning	50		
10.1	Safety measures before carrying out cleaning work.....	50		
10.2	Cleaning.....	50		
10.2.1	Exterior cleaning.....	50		
10.2.2	Interior cleaning.....	50		
10.2.3	Cleaning of strainer insert and suction filter.....	50		
11.	Maintenance	51		
11.1	Safety measures before carrying out maintenance works.....	51		
11.2	Maintenance.....	51		
11.3	Maintenance plan.....	51		
11.4	Clean the strainer insert.....	52		
11.5	Clean the suction filter.....	52		
11.6	Interior cleaning of the oil reservoir.....	52		
12.	Repair	53		
12.1	Safety measures before carrying out repair works.....	53		
12.2	Replace strainer insert.....	53		
12.3	Replace suction filter.....	53		
12.4	Replace pressure unit.....	54		
12.4.1	Dismantle defective pressure unit.....	54		
12.4.2	Install new pressure unit.....	55		
13.	Troubleshooting	56		
14.	Final shutdown and disposal	57		
14.1	Temporary shutdown.....	57		
14.2	Final shutdown and disassembly.....	57		
14.3	Disposal.....	57		
15.	Spare parts and accessories	58		
15.1	Pump assy. EOP2-12.....	58		
15.2	Pump assy. EOP2-24.....	58		
15.3	Pressure unit assy.....	59		
15.4	Screw lid.....	59		
15.5	Suction filter.....	59		
15.6	Strainer insert.....	60		
15.7	Connection cable.....	60		

15.8	Plastic tube.....	60
15.9	Gaskets.....	61
15.10	Adhesive label	61
15.11	Screw cap	61
15.12	Optional accessories.....	62
15.12.1	Quicklinc connectors for connecting metering elements, brushes and filling connections to the divider bar, plug-in type..	62
15.12.2	Quicklinc connectors for EOP oil pump, reservoir + divider bars	62
15.12.3	Closure plugs of the divider bar	63
15.12.4	Brush	63
15.12.5	EOE metering elements	64
15.12.6	Divider bar.....	65
15.12.7	Tube clamp	65
15.12.8	Feed lines	65
15.12.9	Brackets and elbows.....	66

Explanation of symbols, signs and abbreviations

The following abbreviations may be used within these instructions. Symbols within safety notes mark the kind and source of the hazard.

	General warning		Dangerous electrical voltage		Risk of falling		Hot surfaces
	Unintentional intake		Crushing hazard		Pressure injection		Suspended load
	Electrostatically sensitive components						
	Wear personal protective equipment (goggles)		Wear personal protective equipment (face shield)		Wear personal protective equipment (gloves)		Wear personal protective equipment (protective clothes)
	Wear personal protective equipment (safety shoes)		Release the product.		General obligation		
	Keep unauthorized persons away.						
	CE marking		Disposal, recycling		Disposal of waste electrical and electronic equipment		

	Warning level	Consequence	Probability	Symbol	Meaning
	DANGER	Death, serious injury	imminent	●	Chronological guidelines
	WARNING	Death, serious injury	possible	○	Lists
	CAUTION	Minor injury	possible		Refers to other facts, causes, or consequences
	NOTICE	Property damage	possible		

Abbreviations and conversion factors

A	ampere	cpl.	complete	e.g.	for example
AC	alternating current	kW	kilowatt	>	greater than
Ah	Ampere hour	l	litre	<	less than
re.	regarding	lb.	pound	±	plus/minus
°C	degrees Celsius	max.	maximum	∅	Diameter
approx.	approximately	min.	minimum	≈	approximately
cc	cubic centimetre	min.	minute	=	equal to
cSt	centi Stokes	ml	millilitre	%	per cent
cu. in.	cubic inch	ml/d	millilitre per day	‰	per mille
d	day	mm	millimetre	≥	greater than
dB (A)	Sound pressure level	mm ²	square millimetre	≤	less than
DC	direct current	mph	miles per hour		
i.e.	that is	N	Newton		
etc.	et cetera	nc	normally closed		
poss.	possibly	Nm	Newtonmeter	Conversion factors	
°F	degrees Fahrenheit	no	normally open contact	Length	1 mm = 0.03937 in.
fl. oz.	fluid ounce	Oz	Ounce	Area	1 cm ² = 0.155 sq.in
fpsec	feet per second	PA	Polyamide	Volume	1 ml = 0.0352 fl.oz.
gal.	gallon	PP	Polypropylene		1 l = 2.11416 pints (US)
if appl.	if applicable	psi	pounds per square inch	Mass	1 kg = 2.205 lbs
h	hour	R	Resistance		1 g = 0.03527 oz.
hp	horse power	rh	relative humidity	Density	1 kg/cc = 8.3454 lb./gal(US)
Hz	Frequency [Hertz]	rpm	revolutions per minute		1 kg/cc = 0.03613 lb./cu.in.
I	Current	s	second	Force	1 N = 0.10197 kp
a.a.r.	as a rule	sq. in.	square inch	Pressure	1 bar = 14.5 psi
in.	inch	U	Voltage	Temperature	°C = (°F-32) x 5/9
incl.	including	rpm ⁻¹	revolutions per minute	Output	1 kW = 1.34109 hp
K	Kelvin	etc.	et cetera	Acceleration	1 m/s ² = 3.28084 ft./s ²
kg	Kilogram	V	Volt	Speed	1 m/s = 3.28084 fpsec.
kp	kilopound	W	watt		1 m/s = 2.23694 mph

1. Safety instructions

1.1 General safety instructions

- The owner must ensure that safety information has been read by any persons entrusted with works on the product or by those persons who supervise or instruct the before-mentioned group of persons. In addition, the owner must also ensure that the relevant personnel are fully familiar with and have understood the contents of the Instructions. It is prohibited to commission or operate the product prior to reading the Instructions.
- These Instructions must be kept for further use.
- The described products were manufactured according to the state of the art. Risks may, however, arise from a usage not according to the intended purpose and may result in harm to persons or damage to material assets.
- Any malfunctions which may affect safety must be remedied immediately. In addition to these Instructions, general statutory regulations for accident prevention and environmental protection must be observed.

1.2 General behaviour when handling

the product

- The product may be used only in awareness of the potential dangers, in proper technical condition, and according to the information in these instructions.
- Familiarize yourself with the functions and operation of the product. The specified assembly and operating steps and their sequences must be observed.
- Any unclear points regarding proper condition or correct assembly / operation must be clarified. Operation is prohibited until issues have been clarified.
- Keep unauthorized persons away.
- Wear personal protective equipment always.
- Precautionary operational measures and instructions for the respective work must be observed.
- Responsibilities for different activities must be clearly defined and observed. Uncertainty seriously endangers safety.
- Safety-related protective and emergency devices must not be removed, modified or affected otherwise in their function

and are to be checked at regular intervals for completeness and function.

- If protective and safety equipment has to be dismantled, it must be reassembled immediately after finishing the work, and then checked for correct function.
- Remedy occurring faults in the frame of responsibilities. Immediately inform your superior in the case of faults beyond your competence.
- Never use parts of the centralized lubrication system or of the machine as standing or climbing aids.

1.3 Intended use

The electrical oil pump EOP2 serves to be integrated in a lubrication system for lubrication of chain drives in the agricultural and

construction machinery sector as well as in the industry.

The pump should be used only within commercial machines or systems. Full compliance with any information and documents referenced in these instructions, particularly with the safety information, is part of the intended use. Any other use is considered to be improper use.

1.4 Foreseeable misuse

Any usage of the product differing from the aforementioned conditions and stated purpose is strictly prohibited. Particularly prohibited are:

- Use in continuous operation
- Use of waste oils, gear oils, glycol oils or vegetable oils
- outside the indicated temperature range
- with non-specified means of operation
- in areas with aggressive or corrosive materials (e.g. high ozone pollution).
- in areas with harmful radiation (e. g. ionising radiation)

- to supply, transport, or store hazardous substances and mixtures in accordance with annex I part 2-5 of the CLP regulation (EG 1272/2008) and marked with GHS01 - GHS06 and GHS08 hazard pictograms
- to feed, forward, or store gases, liquefied gases, dissolved gases, vapours, or fluids whose vapour pressure exceeds normal atmospheric pressure (1013 mbar) by more than 0.5 bar at the maximum permissible operating temperature.
- Use in an explosive atmosphere

1.5 Painting of plastic parts

- Painting of any plastic parts or seals of the described products is expressly prohibited. Remove or completely tape parts concerned before painting the superior machine.

1.6 Notes related to the CE marking

CE marking is effected following the requirements of the applied directives:

- 2014/30/EU Electromagnetic compatibility
- 2011/65/EU (RoHS II) Directive on the restriction of the use of certain hazardous substances in electrical and electronic equipment

1. Safety instructions

Reference on Low Voltage Directive 2014/35/EU

The protective regulations of Low Voltage Directive 2014/35/EU are fulfilled according to annex I (1.5.1) of Machinery Directive 2006/42/EC.

Reference on Pressure Equipment Directive 2014/68/EU

Because of its performance data the product does not achieve the limit values defined in Article 4 (1) (a) (i) and is therefore excluded from the scope of application of Pressure Equipment Directive 2014/68/EU following Article 4 (3).

1.7 Modifications of the product

Unauthorized conversions or modifications may result in unforeseeable impacts on safety and functionality. Therefore, any unauthorized conversions or modifications are expressly prohibited.

1.8 Inspections prior to delivery

The following inspections were carried out prior to delivery:

- Safety and functional tests
- In case of electrically operated products: Electrical inspections following DIN EN 60204-1:2007 / VDE 0113-1:2007.

1.9 Other applicable documents

In addition to these instructions, the following documents must be observed by the respective target group:

- Operational instructions and approval rules
- Safety data sheet (MSDS) of the lubricant used.

Where appropriate:

- Project planning documents
- Any documents of other components required to set up the centralized lubrication system

The operator must supplement these documents with the relevant applicable national

regulations of the country of use. When selling or forwarding the product, make sure to attach these Instructions to it.

1.10 Notes related to the type identification plate

The type identification plate states important characteristics such as type designation, order number, and regulatory characteristics.

To ensure that the loss of data due to an illegible type identification plate is avoided, the characteristics should be entered in the Instructions.

Model: _____ S. No. _____

P. No. _____ Year of construction (MM/YY)

Type identification plate EOP2 - 12 V Fig. 1

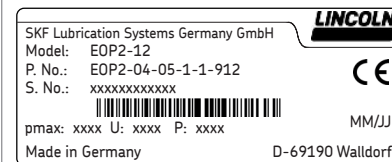

Type identification plate EOP2 - 24 V Fig. 2

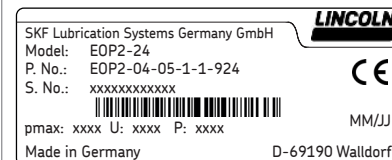

1.11 Persons authorized to operate the pump

1.11.1 Operator

A person who is qualified by training, knowledge and experience to carry out the functions and activities related to normal operation. This includes avoiding possible hazards that may arise during operation.

1.11.2 Specialist in mechanics

Person with appropriate professional education, knowledge and experience to detect and avoid the hazards that may arise during transport, installation, start-up, operation, maintenance, repair and disassembly.

1.11.3 Specialist in electrics

Person with appropriate professional education, knowledge and experience to detect and avoid the hazards that may arise from electricity.

1.12 Briefing of external technicians

Prior to commencing the activities, external technicians must be informed by the operator of the company safety provisions, the applicable accident prevention regulations to be maintained, and the functions of the superordinate machine and its protective devices.

1.13 Provision of personal protective equipment

The operator must provide suitable personal protective equipment for the respective location of operation and the purpose of operation.

1.14 Operation

The following must be observed during commissioning and operation:

- Any information within this manual and the information within the referenced documents.
- All laws and regulations that the operator must observe.

1.15 Emergency stopping of the pump station

In case of an emergency stop the pump station by:

- Switching off the superior machine or system in which the pump station has been integrated.
- Actuating the emergency stop switch of the superior machine.

1.16 Transport, installation, maintenance, malfunctions, repair, shutdown, disposal

- All relevant persons must be informed of the activity prior to starting any work. Observe the precautionary operational measures and work instructions.
- Carry out transport using suitable transport and hoisting equipment on suitable ways only.
- Maintenance and repair work can be subject to restrictions in low or high temperatures (e.g. changed flow properties of the lubricant). Therefore, where possible, try to carry out maintenance and repair work at room temperature.
- Prior to performing work, the product and the machine, into which the product will be integrated, must be depressurized and secured against unauthorized activation.
- Ensure through suitable measures that movable or detached parts are immobilized during the work and that no limbs can be caught in between by inadvertent movements.
- Assemble the product only outside of the operating range of moving parts, at an adequate distance from sources of heat or cold. Other units of the machine or vehicle must not be damaged or impaired in their function by the installation.
- Dry or cover wet, slippery surfaces accordingly.
- Cover hot or cold surfaces accordingly.
- Work on electrical components must be carried out by electrical specialists only. Observe any waiting periods for discharging, if necessary. Carry out works on electrical components using voltage insulated tools only.
- Carry out electrical connections only according to the information in the valid wiring diagram and taking the relevant regulations and the local connection conditions into account.
- Do not touch cables or electrical components with wet or damp hands.
- Fuses must not be bypassed Replace defective fuses always by fuses of the same type.
- Ensure proper grounding of the product.
- Undertake drilling at non-critical, non-load bearing parts only. Use any available boreholes. Do not damage lines and cables when drilling.
- Observe possible abrasion points. Protect the parts accordingly.

- All components used must be designed according to the maximum operating pressure and the maximum respectively minimum operating temperature.
 - No parts of the centralized lubrication system may be subjected to torsion, shear, or bending.
 - Check all parts prior to their usage for contamination and clean, if necessary.
 - Observe the specified tightening torques. When tightening, use a calibrated torque wrench.
 - When working with heavy parts use suitable lifting tools.
 - Avoid mixing up or wrong assembly of dismantled parts. Mark these parts accordingly.
- 1.17 Initial commissioning / daily start-up**
- Ensure that:
- All safety devices are completely available and functional
 - All connections are correctly connected
 - All parts are correctly installed
 - All warning labels on the product are present completely, highly visible and undamaged
 - Illegible or missing warning labels are to be replaced without delay
 - The machine is correctly earthed
- 1.18 Cleaning**
- Risk of fire and explosion when using inflammable cleaning agents. Only use non-flammable cleaning agents suitable for the purpose.
 - Do not use aggressive cleaning agents.
 - Thoroughly remove residues of cleaning agents from the product.
 - Do not use steam jet and high pressure cleaners. Electrical components may be damaged. Observe the IP type of protection of the pump.
 - Cleaning work on energized components may be carried out by electrical specialists only.
 - Mark damp areas accordingly.

1.19 Residual risks

Residual risk	Prevention/ remedy
Life cycle: Transport, assembly, start-up, operation, malfunction, troubleshooting, repair, maintenance, shutdown, disposal	
Dropping of lifted parts or tools	<ul style="list-style-type: none"> No people may remain under suspended loads. Keep unauthorized persons away. Secure suspended loads using suitable hoisting equipment (e.g. tapes, belts, ropes, etc.).
Falling of parts through insufficient fixing to the machine	<ul style="list-style-type: none"> Fix parts only to machine parts with sufficient load capacity. Observe the weight. Observe the stated tightening torques. If no tightening torques are stated, apply tightening torques according to the screw size characteristics for 8.8 screws. Literature, see screw manufacturer.
Electrical shock due to defective connection cable	<ul style="list-style-type: none"> Check connection cable for damages.
People slipping due to floor contamination with spilled or leaked lubricant	<ul style="list-style-type: none"> Be careful when connecting or disconnecting lubricant feed lines Promptly apply suitable binding agents to remove the leaked or spilled lubricant. Follow the operational instructions for handling lubricants and contaminated parts
Tearing or damaging of lines when installed on moving machine parts	<ul style="list-style-type: none"> If possible, do not install on moving parts. If this cannot be avoided, use flexible hose lines
Ripping out/ damage to lines due to assembly at chafing points or assembly with too little bending radius	<ul style="list-style-type: none"> Use protective pipes or spring coils

Residual risk	Prevention/ remedy
Lubricant spraying out due to faulty component fitting or line connection	<ul style="list-style-type: none">○ Use suitable hydraulic screw connections and lines for the stated pressures. Check these prior to commissioning for correct connection and damage.
Life cycle: Transport, assembly, start-up, operation, malfunction, troubleshooting, repair, maintenance, shutdown, disposal	
Contamination of the environment with lubricant and wetted parts	<ul style="list-style-type: none">○ Dispose of the parts following the valid legal and company regulations.

2. Lubricants

2.1 General information

Lubricants are used specifically for certain application purposes. In order to fulfil their tasks, lubricants must fulfil various requirements to varying extents.

The most important requirements for lubricants are:

- Reduce friction and wear
- Corrosion protection
- Noise minimisation
- Protection against contamination or penetration of foreign objects
- Cooling (primarily with oils)
- Longevity (physical/ chemical stability)
- economic and ecological aspects

2.2 Selection of lubricants

SKF considers lubricants to be an element of system design. A suitable lubricant is se-

lected already when designing the machine and forms the basis for the planning of a centralized lubrication system.

The selection is made by the manufacturer or operator of the machine, preferably together with the lubricant supplier based on the requirement profile defined by the specific application.

Should you have little or no experience with the selection of lubricants for centralized lubrication systems, please contact SKF.

If required we will be glad to support customers to select suitable components for feeding the selected lubricant and to plan and design their centralized lubrication system.

You will avoid possible downtimes through damage to your machine or system or damage to the centralized lubrication system.

2.3 Material compatibility

Lubricants must generally be compatible with the following materials:

- steel, grey iron, brass, copper, aluminium
- NBR, FPM, ABS, PA, PU

2.4 Temperature characteristics

The lubricant used must be suitable for the specific operating temperature of the product. The viscosity required for proper operation of the product must be adhered to. It must not be exceeded in case of low temperatures nor fall below specification in case of high temperatures. Specified viscosities, see chapter Technical data.

2.5 Ageing of lubricants

After a prolonged downtime of the machine, the lubricant must be inspected prior to re-commissioning as to whether it is still suitable for use due to chemical or physical ageing. We recommend that you undertake this inspection already after a machine downtime of 1 week.

If doubts arise as to a further suitability of the lubricant, please replace it prior to re-

commissioning and, if necessary, undertake initial lubrication manually.

It is possible for lubricants to be tested in the company's laboratory for their suitability for being pumped in centralized lubrication systems (e.g. "bleeding").

Please contact SKF if you have further questions regarding lubricants.

You may request an overview of the lubricants tested by SKF.



Only lubricants specified for the product (see chapter Technical data) may be used. Unsuitable lubricants may lead to a failure of the product.



Do not mix lubricants. This may have unforeseeable effects on the usability and therefore on the function of the centralized lubrication system.



When handling lubricants the relevant safety data sheets and hazard designations, if any, on the packaging have to be observed.



Due to the multitude of possible additives, it is possible that individual lubricants, which according to the manufacturer's data sheets fulfil the necessary specification, are not in fact suitable for use in centralized lubrication systems (e.g. incompatibility between synthetic lubricants and materials). In order to avoid this, always use lubricants tested by SKF.

3. Overview, functional description

1 Filling port with screw lid

The lubricant is filled into the oil reservoir via the filling port.

2 Oil reservoir

Oil reservoir for lubricating oil with filling level marking for maximum and minimum oil volumes.

3 Strainer insert

The strainer insert is mounted in the filling port of the oil reservoir and prevents dirt particles from entering.

4 Screw cap

The screw cap is to drain oil from the oil reservoir.

5 Deutsch connector

The electrical connection of the pump is carried out via the 2-pole connector.

6 Gear pump

The gear pump supplies lubricating oil to the connected metering devices.

7 Connection fitting

A lubrication line can be connected to the connection fitting.

Overview Fig. 3

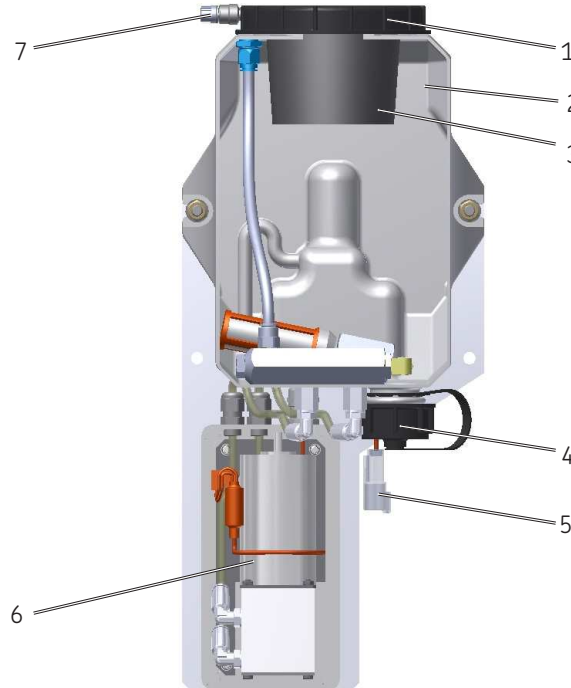

8 Mounting bracket

The product is fastened on the mounting bores ($\varnothing 8.5$) of the mounting bracket. ($\varnothing 8.5$) of the mounting bracket.

9 Suction filter

The oil inside the oil reservoir flows through the suction filter, where any dirt particles are filtered out. The filter is positioned horizontally inside the oil reservoir.

10 Pump housing

The pump housing protects the gear pump and the motor.

11 Pressure unit

The pressure unit consists of a pressure control valve and a pressure relief valve. The pressure control valve keeps the pump pressure at constant 4 bar maximum. If the pump is switched off, the pressure relief valve relieves the oil pressure from the pressure unit and the pressure line to the oil reservoir.

Overview Fig. 4

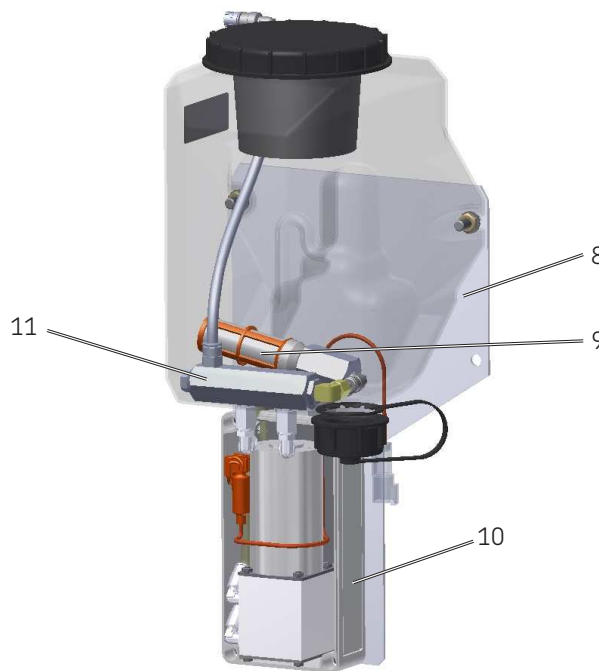

12 Filling level label

The label serves to control the filling level. The filling level must remain above the minimum filling level (MIN) and below the maximum filling level (MAX).

Overview Fig. 5

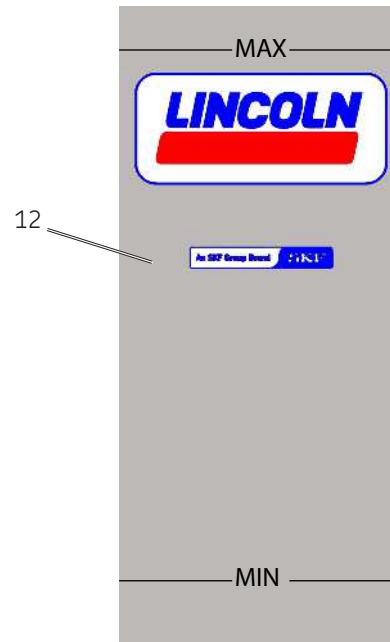

4. Technical data

4.1 General technical data

Admissible operating temperature range	-10 °C to + 70 °C
Operating pressure	4 bar max.
Connection fitting	Plug-in type connection Ø 4, Ø 6 and Ø 8 mm
Operating mode ¹ following DIN EN 60034-1 (VDE 0530-1)	S3, 20% (1.25 - 25 min)
Installation position	vertical, screw lid upwards
Sound pressure level	< 70 dB (A)
Empty weight	approx. 4.4 kg
Output volume ²	150 cc/min
Useful volume of the oil reservoir	3.5 l between MIN and MAX Initial filling 4.2 l
Approved lubricants	Mineral oil or vegetable oil based on ester in the admissible range of operating viscosity
Admissible range of operating viscosity	min. 20 mm ² /s max. 2000 mm ² /s

¹ Operating mode S3 (periodic intermittent duty) describes the relation between pump run time and the subsequent idleness of the motor

² Referring to an operating viscosity of 140 mm²/s (cSt) at a back pressure of p = 4 bar

4.2 Electrics and control unit

Rated voltage	12 V DC or 24 V DC \pm 10% PELV	
Rated current (maximum)	12 V DC	6.2 A
	24 V DC	3.1 A
Starting current	12 V DC	max. 25 A
	24 V DC	max. 12 A
Back-up fuse (fuse following DIN 72581 T3)	12 V DC	10 A
	24 V DC	7,5 A
Rated power (maximum)	\leq 50 W	
Type of protection	IP65	
Length of connection cable (maximum)	at 1mm ² , length of cable \leq 12m	
Connector	Deutsch connector DT04-2P, 2-pole Pin 1 brown (-), Pin 2 red (+)	

4.3 Type identification code

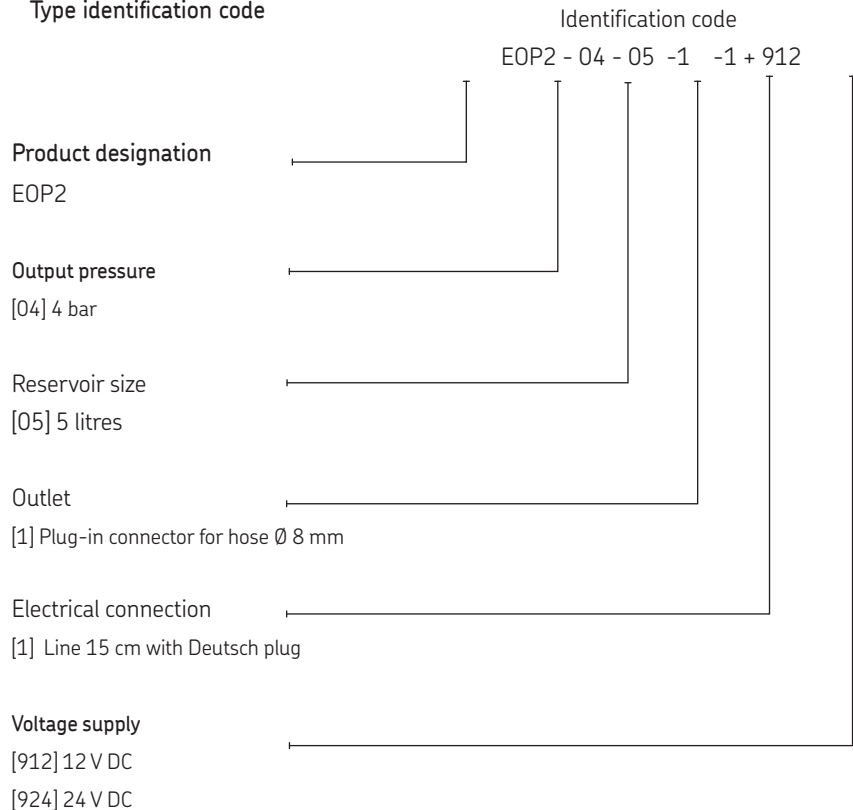

Other types on request

5. Delivery, returns, and storage

5.1 Delivery

After receipt of the shipment, check the shipment for damage and completeness according to the shipping documents. Immediately report any transport damages to the forwarding agent.

Keep the packaging material until any discrepancies are resolved. During in-house transport ensure safe handling.

5.2 Returns

Clean parts and pack them properly, i.e. following the regulations of the recipient country, before returning them.

Protect the product against mechanical influences such as impacts. There are no restrictions for land, sea or air transport.

Mark returns on the packaging as follows.

- shield product from nearby sources of heat and coldness.
- in case of high temperature fluctuations or high humidity take adequate measures (e. g. heater) to prevent the formation of condensation water.
- the admissible storage temperature range corresponds to that of the operating temperature (see Technical data)

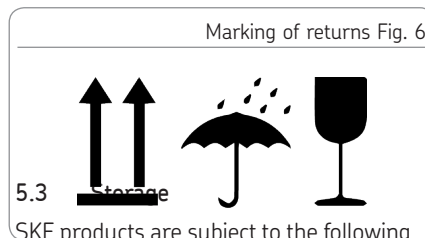

5.3 Storage

SKF products are subject to the following storage conditions:

- dry, dust- and vibration-free in closed premises
- no corrosive, aggressive materials at the place of storage (e. g. UV rays, ozone)
- protected against pests and animals (insects, rodents, etc.)
- possibly in the original packaging



Before application inspect the products with regard to possible damages occurred during their storage. This particularly applies for parts made out of plastic and rubber (embrittlement) as well as for components primed with lubricant (ageing).

6. Installation

6.1 General information

Only qualified technical personnel may install, operate, maintain, and repair the products described in these Instructions. Qualified technical personnel are persons who have been trained, assigned, and instructed by the operator of the final product, into which the described product shall be integrated.

Such persons are familiar with the relevant standards, rules, accident prevention regulations, and assembly conditions as a result of their training, experience, and instruction. They are qualified to carry out the required activities and in doing so recognize and avoid any potential hazards.

Before assembling the product, the packaging material as well as possible transport locking devices must be removed.

Keep the packaging material until any discrepancies are resolved.



6.2 Installation

Protect the product against humidity and vibration and install it in an easily accessible position to ensure all other installations can be carried out without any problem. Observe the IP type of protection.

During assembly always pay attention to the following:

- Prior to performing work, the product and the machine or system in which the product is or will be integrated must be depressurized and secured against unauthorized activation
- The product must be mounted onto a stable and plane surface of at least 420 x 210 mm
- Other units must not be damaged by the assembly

- The product must not be installed within the range of moving parts
- The product must be installed at an adequate distance from sources of heat and coldness
- Adhere to safety distances and legal prescriptions on assembly and prevention of accidents

		CAUTION
<p>Live components: Electric shock when touching.</p> <p>Make sure to disconnect the product from the power supply before carrying out any works on live parts.</p>		

6.3 Mechanical connection

6.3.1 Minimum assembly dimensions

Ensure sufficient space for the installation or for possible maintenance or repair works of the product by leaving a free space of at least 100 mm into each direction in addition to the stated dimensions. Mount the pump vertically with the screw lid showing upwards.

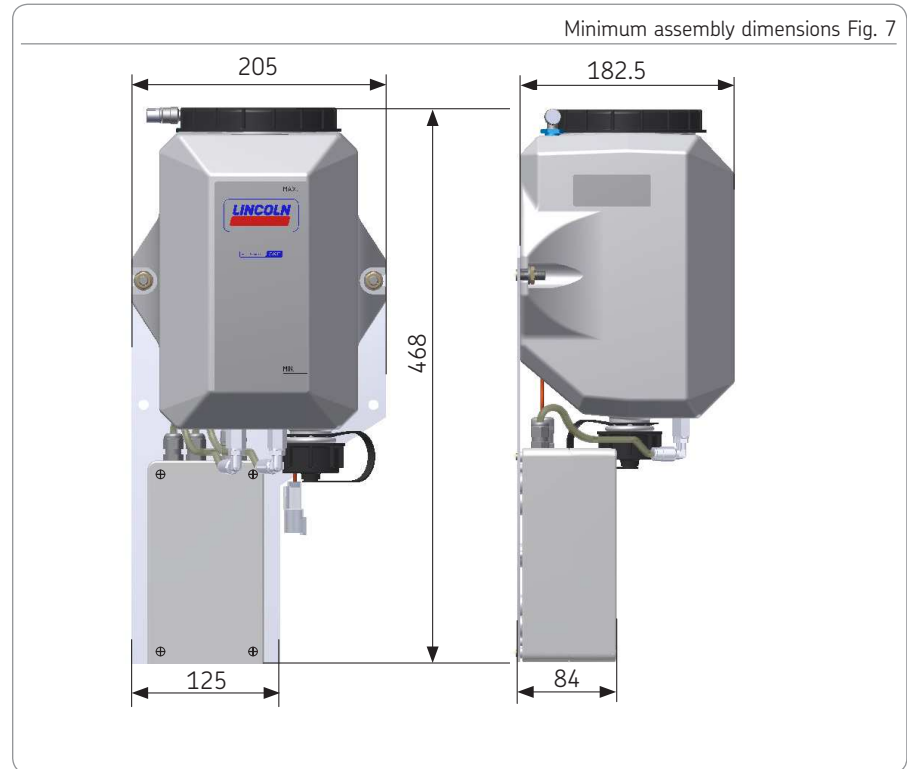

6.3.2 Installation bores

The product is fastened to the 4 mounting bores (8.1). For transport purposes the pump is attached to the bracket with plastic plugs on the upper two mounting bores.

Screws of strength class 8.8

Tightening torque = 10 Nm \pm 1 Nm

The pump must be connected with the lubrication line and, where applicable, with metering devices. Control is realized by means of an external control unit provided by the operator.



The mounting face must be stable and plane with a dimension of at least 420 x 210 mm.

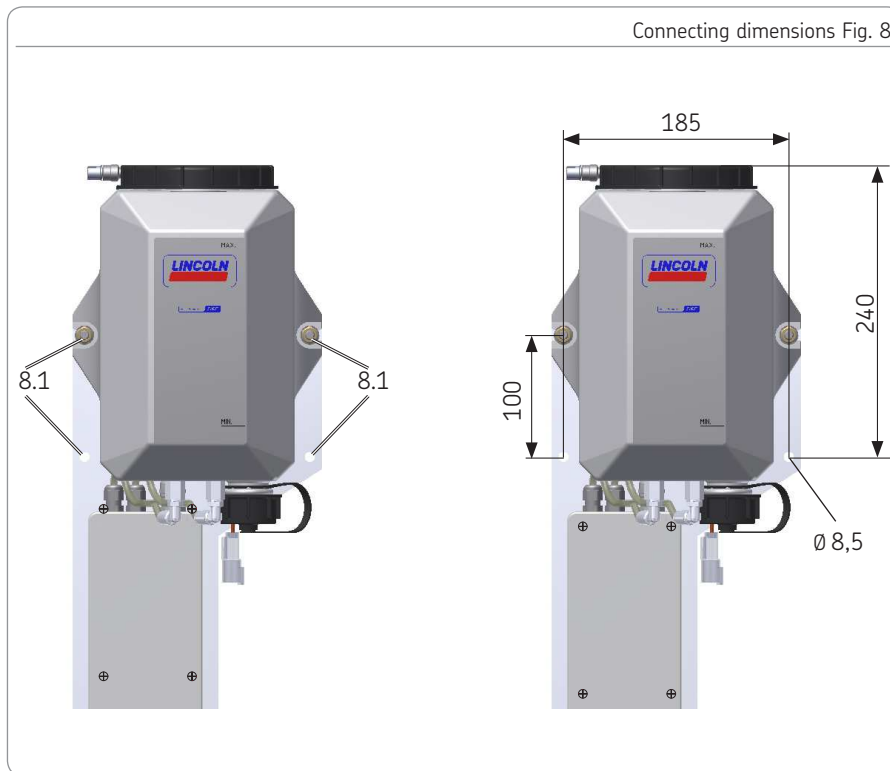

6.4 Electrical connection

Electrical connections must be done in such way that no forces are transferred to the connecting cable.

		CAUTION
<p>Live components: Electric shock when touching.</p> <p>Make sure to disconnect the product from the power supply before carrying out any works on live parts.</p>		

For electrical connection proceed as follows:

- Connect the Deutsch plug (5) to the power supply

Electrical connection of the pump to the operator's network is done in dependency of the local connection conditions. To do so, observe the electrical characteristics (see chapter Technical Data). Electrical connection of the pump must be carried out by a qualified electrician always.

Electrical connection, Fig. 9

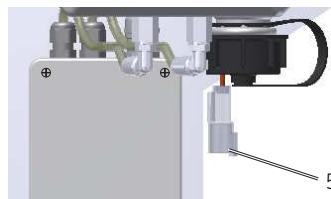

Pin assignment Fig. 10

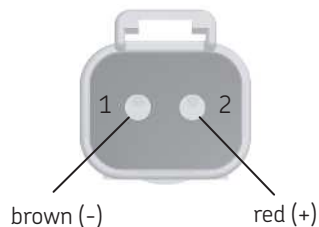

7. Initial start-up

For initial start-up proceed as follows.

7.1 Fill the pump

- Unscrew the screw lid (1)
- Fill in clean oil up to the middle of the MAX filling-level marking
- Position screw lid again and firmly tighten it

7.2 Vent the pump

After the first filling procedure or when it is empty, the pump must be vented.

To vent the pump (Fig. 12) proceed as follows:

- Provide suitable leakproof reservoir to collect the oil
- Firmly press left-hand hose (13) into plug-in connector
- Press outer ring of plug-in connector and keep it pressed
- Pull hose out of plug-in connector (14)

☞ Oil will leak.

- Attach left-hand hose (13) in plug-in connector (14) again

- Eliminate collected oil

If no oil has leaked, proceed as follows:

- Provide suitable leakproof reservoir to collect the oil
- Firmly press left-hand hose (13) into plug-in connector
- Keep outer ring of plug-in connector pressed
- Pull hose out of plug-in connector (14)
- Activate pump
- Let the pump run several times until oil will leak
- As soon as oil has leaked, attach hose to plug-in connector again
- Eliminate collected oil

The pump has been vented and can be activated after the necessary safety controls (see next page).

Filling Fig. 11

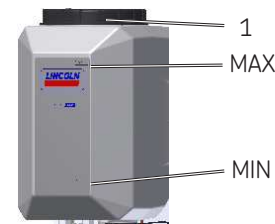

Venting Fig. 12

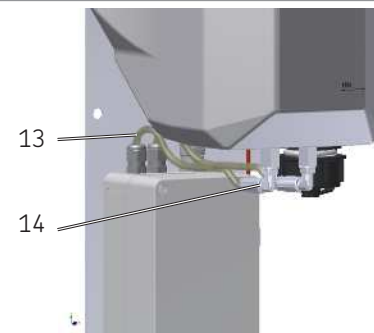

7.3 Inspections prior to initial activation

In order to warrant safety and function, prior to the initial activation check the following:

	YES	NO
Mechanical connections carried out correctly	<input type="checkbox"/>	<input type="checkbox"/>
Electrical connection carried out correctly.	<input type="checkbox"/>	<input type="checkbox"/>
The performance data of the previously indicated connections correspond to the specifications stated in the Technical data	<input type="checkbox"/>	<input type="checkbox"/>
All components, such as lubrication lines and metering devices, have been correctly installed	<input type="checkbox"/>	<input type="checkbox"/>
The reservoir has been filled with suitable lubricant (under observation of MIN/MAX) and the pump has been vented.	<input type="checkbox"/>	<input type="checkbox"/>
Specifications of the lubricant used correspond to the indications stated in the Technical data	<input type="checkbox"/>	<input type="checkbox"/>
The suction filter is positioned horizontally in the oil reservoir	<input type="checkbox"/>	<input type="checkbox"/>
No visible damage, contamination and corrosion	<input type="checkbox"/>	<input type="checkbox"/>
Any dismantled protection and monitoring equipment has been reassembled and checked for correct function	<input type="checkbox"/>	<input type="checkbox"/>
The external control unit provided by the owner has been checked for correct operating status	<input type="checkbox"/>	<input type="checkbox"/>



Remedy occurring faults prior to the initial start-up in the frame of responsibilities. Immediately inform your superior in the case of faults beyond your competence.

7.4 Pump activation

As soon as all previous checks and activities have been carried out, the pump can be activated.

Activation is done by:

- Connection to the power supply
- External control unit provided by the owner

7.5 Inspections during the initial activation

In order to warrant safety and function, during the initial activation check the following:

	YES	NO
No unusual noises, vibrations, accumulation of fluids, or odours present	<input type="checkbox"/>	<input type="checkbox"/>
No unwanted escape of lubricant from connections	<input type="checkbox"/>	<input type="checkbox"/>
Chains and friction points to be lubricated are provided with the planned amount of lubricant	<input type="checkbox"/>	<input type="checkbox"/>



Remedy occurring faults in the frame of responsibilities. Immediately inform your superior in the case of faults beyond your competence.

8. Designing an EOS oil system

8.1 Overview, functional description

15. Divider bars

The divider bar (15) serves to install the metering elements (16). There are available divider bars for two, three, four and five metering elements.

16. Metering element

The metering element (16) supplies a prescribed amount of oil via the lubrication lines directly to the brush (17) of a lubrication point.

17. Brush

The brush (17) rests on the lubrication point or roller chain and evenly distributes the dispensed lubricant.

19. Screw-in fitting

The screw-in fitting (19) is used to connect the brush to the lubrication line.

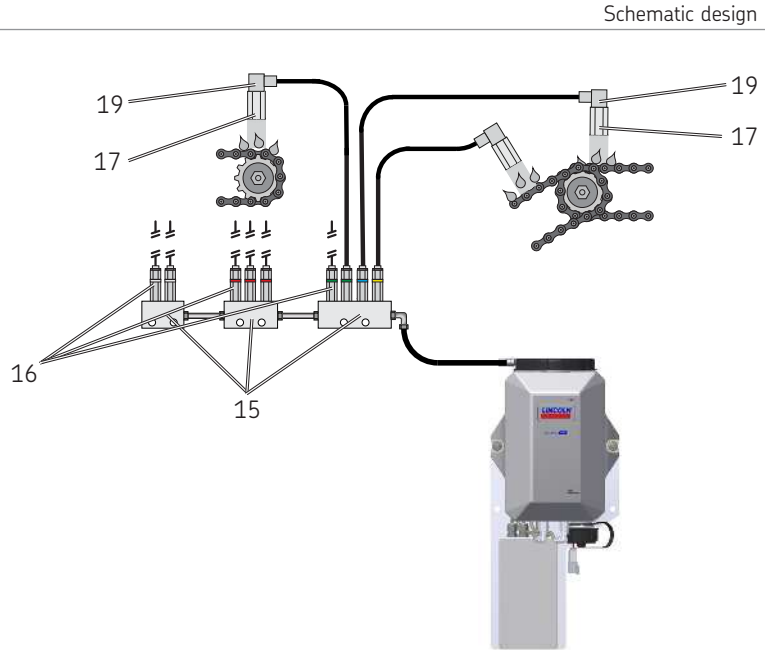

20. Chuck

When pressing the line into the connector together with the chuck, the clamping claws are released.

19. Straight screw-in fitting GEZ

R1/8, Ø 4 mm

22. Bulkhead connector

Inner Ø R1/8

21. Straight screw-in fitting GEZ

R1/8, Ø 8 mm

Quicklinec connector Fig. 14

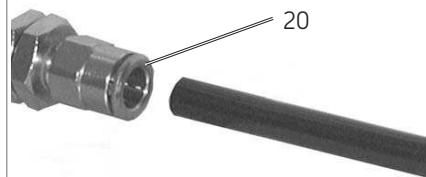

Filling adapter Fig. 15



Divider bar Fig. 16

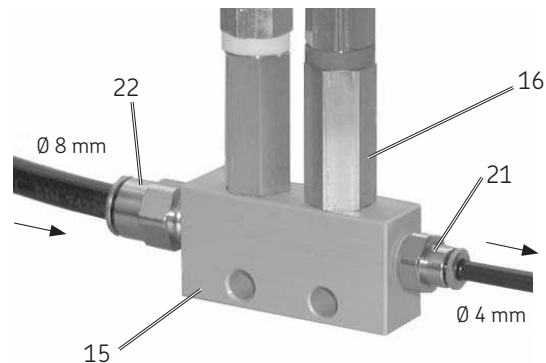

8.2 Technical data of the metering element

8.2.1 Output

Coloured ring	Output/ stroke
white	0.1 cc
red	0.3 cc
green	0.4 cc
blue	0.5 cc
yellow	1.0 cc

8.2.2 Dimensions of the metering element

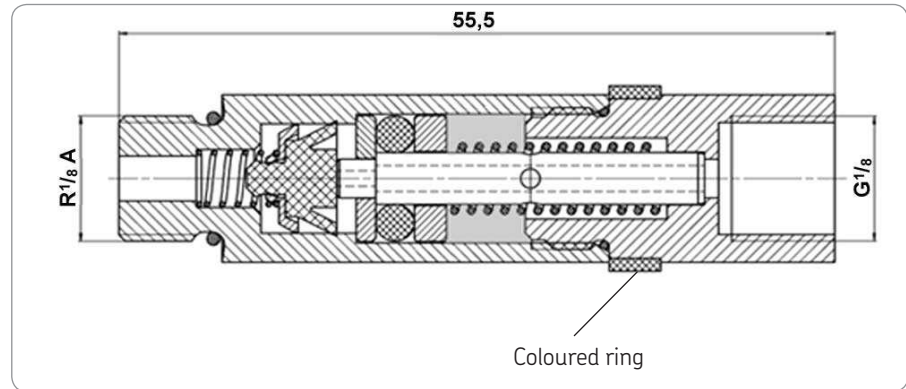

8.3 Installation

8.3.1 General information

Only qualified technical personnel may install the products described in these Instructions.

During assembly pay attention to the following:

- Other units must not be damaged by the assembly.
- The product must be installed at an adequate distance from sources of heat and coldness.
- The brush must exert any pressure on the roller chain to avoid premature wear.

- Fix the lubricant feed lines to the vehicle in regular short distances by means of suitable tube clamps or similar fixing material.

NOTICE

Lines must be laid close to the machine / the vehicle. No loops or projecting lines.

NOTICE

For the installation of the bulkhead connection fitting (22) make sure to retain the counter fitting inside of the reservoir.

8.3.2 Place of installation

Protect the product against humidity, dust and vibrations and install it in an easily accessible position to facilitate other installation and maintenance works.

8.3.3 Installation of Quickling connectors in the metering elements

- Choose metering element (16) in accordance with the required output volume.
- Screw straight screw-in fitting GEZ (21) clockwise (CW) into the metering element.

Tightening torque = $6 \text{ Nm} \pm 0.6 \text{ Nm}$

- Repeat procedure for each metering element.

Installation of the screw-in fitting into the metering elements Fig. 17

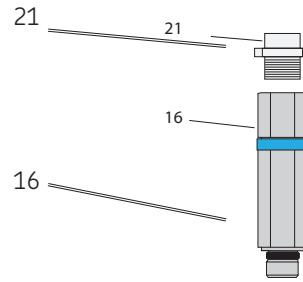

8.3.4 Install metering elements into the divider bar

- Screw the metering element (16) connected to the screw-in fitting (21) clockwise (CW) into the divider bar (15).

Tightening torque = $6 \text{ Nm} \pm 0.6 \text{ Nm}$

- Repeat procedure for all metering elements.

Installation of the metering elements Fig. 18

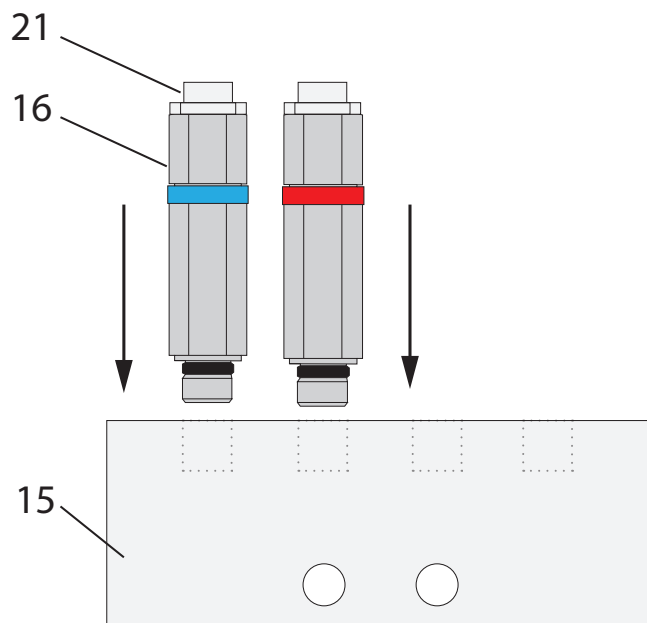

8.3.5 Installation of the divider bar

The divider bar is fixed to the 2 mounting bores (21).

Dimensions	A	B	C	D
(mm)	15	25	35	45

Fastening is done by means of:

2 x screw M6

Tightening torque = $9.9 \text{ Nm} \pm 0.9 \text{ Nm}$

Installation of the divider bar Fig. 19

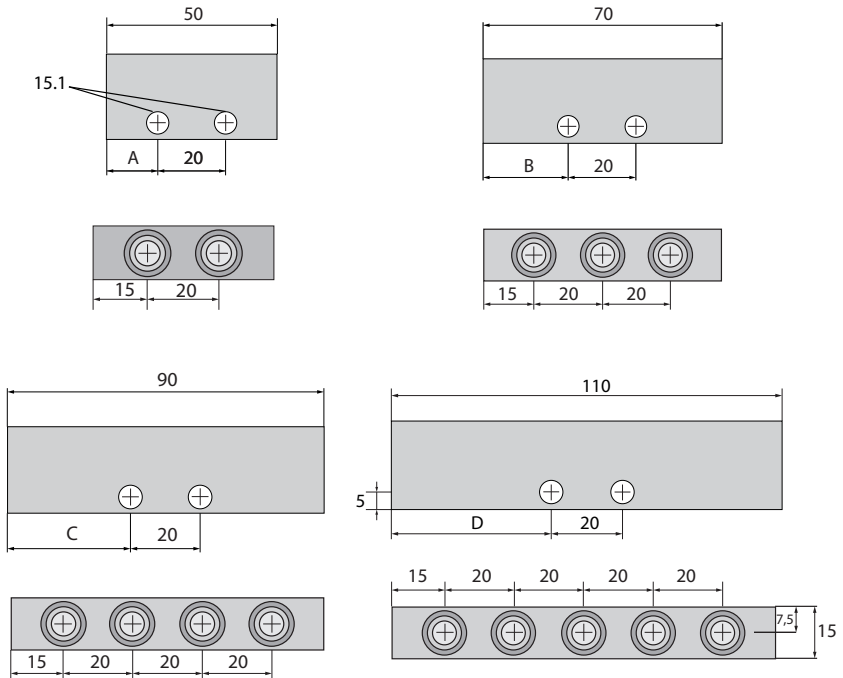

8.3.6 Installation of the divider bar via bracket (option)

Optionally, the divider bar can be fixed by using a bracket.

- Fix the divider bar (12) onto the bracket (22) via the upper (position 1) or the lower mounting bores (position 2).

Tightening torque = $9.9 \text{ Nm} \pm 0.9 \text{ Nm}$

- Fasten the bracket to the fastening bore (23).

Tightening torque = $50 \text{ Nm} \pm 5 \text{ Nm}$

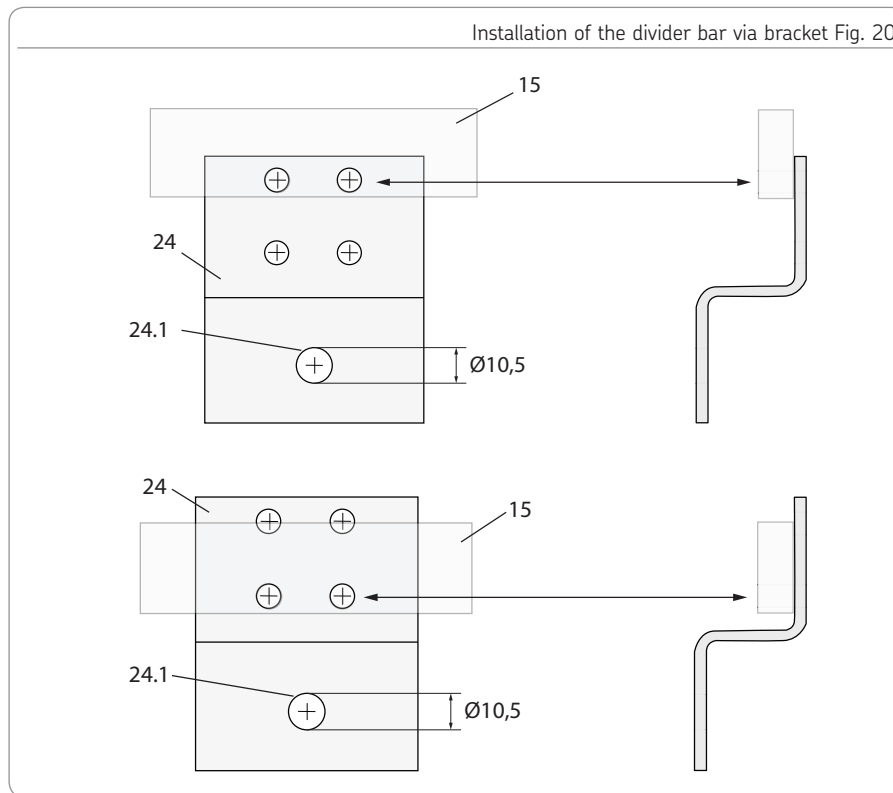

8.3.7 Mounting of the brush

- Connect the brush (17) to the screw-in fitting (19) and the lubrication line.
- Use suitable tube clamp (28) and fastening element (29), e.g. mounting bracket, to attach the brush to the superordinate machine.
- Repeat procedure for all brushes and screw-in fittings.

Mount brush Fig. 21

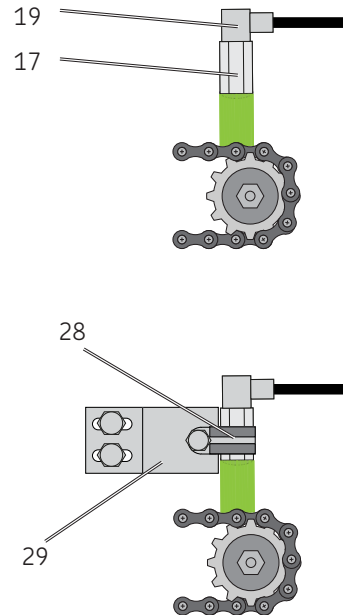

8.3.8 Configuration of the lubrication

NOTICE

Lay lubrication line following DIN 20066 (see data sheet 810-53833-1).

- Do not twist hose lines during installation.
 - If possible, fix hose brackets to straight sections.
 - Adhere to the minimum bending radius of 40 mm.
 - In case of the components that can be moved against each other ensure sufficient buffer of the lubrication line.
 - Lay hose slightly sagging.
 - Keep sufficient distance to edges.
 - Cover sharp-edged components.
 - Protect hose by means of protective hose.
 - Lines must be laid close to the machine / the vehicle.
 - No loops or projecting lines.
- Determine the required type of line for the lubricant supply.
 - Determine the required length of the lubrication line.
 - Lay the lubrication line.

8.3.9 Installation of the line in the QUICKLINC connector

Connection of the line

- Push the line in the direction of the arrow into the Quicklinc connector connected to the metering element.
- Push the line in the direction of the arrow into the Quicklinc connector connected to the brush.

Disconnection of the line

- Press the line into the Quicklinc connector together with the chuck (20) in the direction of the arrow to release the clamping claws.
- Hold chuck (20) and pull out the line against the direction of the arrow.

Quicklinc connector Fig. 22

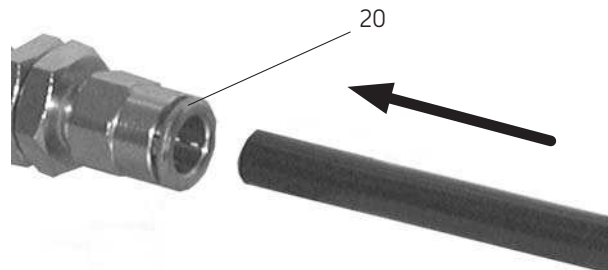

8.3.10 Filling of the oil system

**CAUTION**

Risk of overheating of the electrically operated gear pump in case of permanent operation. For a maximum lubrication time of 4 seconds ensure a subsequent minimum pause time of 30 seconds.

Filling of lubrication lines longer than 0.5 m in the system takes quite some time due to the metering elements. This time can be shortened by a direct connection to the EOP2 oil pump.

- Ensure that the EOP2 oil pump has already been filled with lubricant

Depending on the local space conditions of the installed oil system, you may select one of the following two procedures to fill the system:

Filling via lubricant feed line

- Remove the lubricant feed line from the first divider bar (15, left side)
- Connect filling adapter (Fig. 24) to the lubricant feed line
- Remove the lubrication line from the metering element and connect it with the filling adapter
- Fill the lubrication line by manually triggering additional lubrication cycles of the EOP2 until the lubrication line is completely filled with lubricant
- Reconnect the filled line to the metering element
- Repeat the filling procedure for each lubrication line
- Remove the filling adapter from the lubricant feed line
- Reconnect the free end of the lubricant feed line to the first divider bar

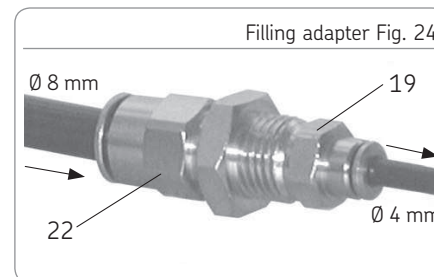
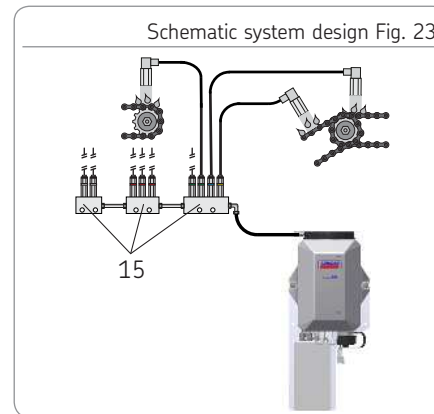

Filling at the end of the divider bar

- Remove the closure screw from the last divider bar (15, right side)
 - Install a screw-in fitting GEZ for lubrication lines (21), \varnothing 4 mm
 - Remove a lubrication line from the metering element and connect it with the filling adapter
 - Fill the lubrication line by manually triggering additional lubrication cycles of the EOP2 until the lubrication line is completely filled with lubricant
 - Reconnect the filled line to the metering element
 - Repeat the filling procedure for each lubrication line
 - Close the screw-in fitting GEZ by means of a closure plug (see chapter "Accessories")
- or
- Remove the screw-in fitting GEZ and close the divider bar again by means of a closure plug (see chapter "Accessories")

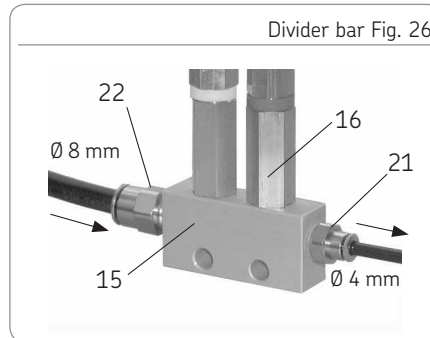
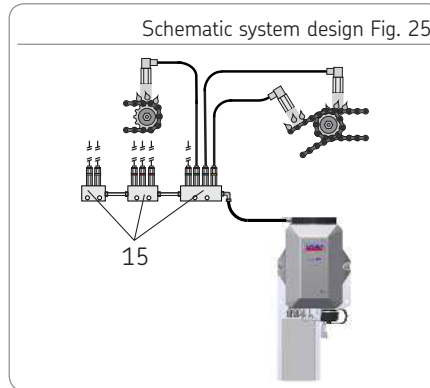

8.3.11 Application example:

As to Fig. A

- Application example with one brush (14)

As to Fig. B

- Application example with two brushes (14)

As to Fig. C

- 4-fold, 3-fold, and 2-fold divider bars (15) with mounted metering elements (output 0,1 - 0,5 cm³) for each lubrication point. (5-Fold divider bar without figure)

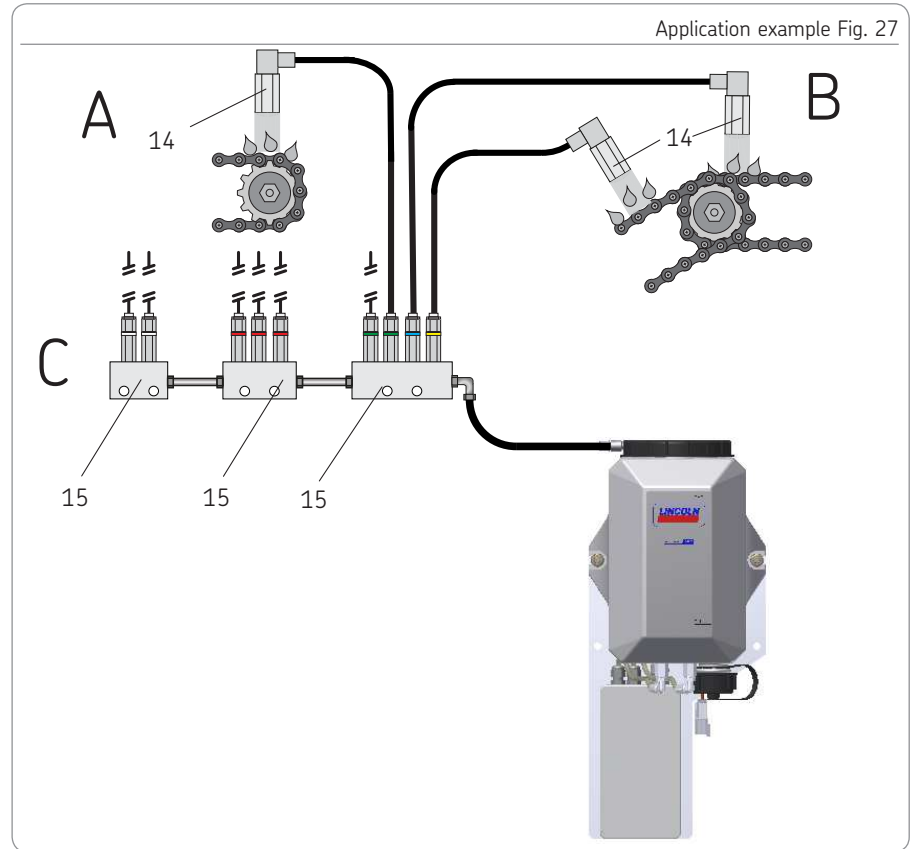

8.4 Troubleshooting

Fault	Possible cause / apparent by:	Remedy
No oil leaking from the brush / poor lubrication	<ul style="list-style-type: none"> ○ Oil reservoir empty ○ Power supply interrupted ○ Fitting or line leaking ○ Brush clogged or worn ○ Metering element(s) defective 	<ul style="list-style-type: none"> ○ Fill the reservoir, vent the pump (see chapter "Initial start-up") ○ Check the power supply ○ Check fittings and lines ○ Replace defective or clogged brush ○ Check and, if necessary, replace metering element(s)
Excessive lubrication	<ul style="list-style-type: none"> ○ Wrong metering element 	<ul style="list-style-type: none"> ○ Check the output volume on the coloured ring of the connected metering element and select metering element with suitable output volume
If the fault cannot be determined and remedied, please contact our Customer Service.		

9. Operation

9.1 Operation

After the initial start-up operation takes place following the desired lubrication and pause times. Thereby the pump is controlled either by the operator or via an external control unit.

The lubrication and pause times depend on the number of lube points as well as of the lengths of the lines in the connected system. SKF products operate automatically to the greatest possible extent. Basically, activities during standard operation are limited to the control of the filling level and the timely refilling of lubricant as well as the outside cleaning of the product in case of contamination.

9.2 Refill lubricant



Depending on the oil reservoir's filling level, in case of a strong terrain incline oil may leak from the oil reservoir or, in case of a strong gradient the pump could take in air.

Description, see chapter Initial start-up.

NOTICE

Falling below the minimum filling level

Damage to the superior machine by too little or lacking lubricant supply.

Daily check the pump filling level.

10. Cleaning

10.1 Safety measures before carrying out cleaning work

Before carrying out any cleaning work, take at least the following safety measures:

- Keep unauthorized persons away.
- Mark and secure work area.
- De-pressurize the product.
- Disconnect the product from the power supply and secure it against being switched on.
- Verify that no power is being applied
- Earth and short-circuit the product.
- Where needed, cover neighbouring units that are live.

10.2 Cleaning

All outer surfaces as well as the trainer insert and suction filter of the pump can be cleaned.

Liability is excluded for any damage or faults arising from inappropriate cleaning.

10.2.1 Exterior cleaning

To clean any exterior surfaces use only mild, pH neutral cleaning agents.



Make sure to keep the oil reservoir closed during the exterior cleaning procedure.

10.2.2 Interior cleaning

Interior cleaning of the reservoir is not necessary. Should cleaning be required, e. g., because of contaminated lubricant filled in accidentally, use a clean cloth and clean oil.

For cleaning, drain the oil via the screw fitting into a suitable leakproof reservoir and

dispose of in an environment-friendly manner. Do not reuse drained oil.



CAUTION

Lubricant squirting out

Skin and eye irritations are possible.

Wear personal protective equipment (protective clothes, protective glasses and gloves).

10.2.3 Cleaning of strainer insert and suction filter

Use a brush and clean oil to clean the strainer insert and the suction filter. Cleaning after visual inspection during minimum filling level. For cleaning of the suction filter, drain the oil via the screw fitting into a suitable leakproof reservoir and dispose of in an environment-friendly manner. Do not reuse drained oil.



CAUTION

Live components:

Electric shock when touching with wet hands.

Make sure to disconnect the product from the power supply before carrying out any works on live parts.

Do not touch cables or electrical components with wet or damp hands.

11. Maintenance

11.1 Safety measures before carrying out maintenance works

Any maintenance works may be carried out by qualified specialists only. Before carrying out any repair work, take at least the following safety measures:

- Prevent access by unauthorised persons
- Mark the working area accordingly
- Disconnect the machine or system into which the product is or will be integrated from the power supply and secure it against unauthorized activation
- Disconnect the product from the power supply
- Protect the product against being switched on unintentionally
- Verify that no power is being applied
- Cover neighbouring units that are live
- Wear personal protective equipment always

11.2 Maintenance



Regular and appropriate maintenance is a prerequisite for smooth operation. Maintenance works have to be determined, verified at regular intervals and adapted, if necessary, by the operator based on the local operating conditions.

SKF

11.3 Maintenance plan

Maintenance intervals	Maintenance works
Before each start-up	<ul style="list-style-type: none"> ○ Check the filling level. If necessary, refill clean lubricant recommended for the pump through the strainer insert. ○ Check for contamination. If necessary clean and replace contaminated lubricant. ○ Check the pump and the connected system for leaks.
Based on the operating conditions at regular intervals to be determined by the operator	<ul style="list-style-type: none"> ○ Check the filling level. If necessary, refill clean lubricant recommended for the pump through the strainer insert. ○ Check for contamination. If necessary clean and replace contaminated lubricant. ○ Check the pump and the connected system for leaks.
Before any filling	<ul style="list-style-type: none"> ○ Check the position of the suction filter ○ Check the strainer insert and, if necessary, clean or replace it. ○ Check the suction filter and, if necessary, clean or replace it.

11.4 Clean the strainer insert

		CAUTION Slipping hazard due to leaking lubricant, Personal injury resulting from falling because of slipping on leaked lubricant. Immediately absorb and remove leaked lubricant.
----------------------------------------------------------------------------------	-----------------------------------------------------------------------------------	---------------------------------------------------------------------------------------------------------------------------------------------------------------------------------------------------

To remove the strainer insert for cleaning purposes, proceed as follows:

- Unscrew the screw lid
- Remove used strainer insert upwards
- Use a brush and clean oil to clean the strainer insert
- Position the clean strainer insert in the filling port again
- Position screw lid again and firmly tighten it

Now the strainer insert has been cleaned.

11.5 Clean the suction filter

To remove the suction filter for cleaning purposes, proceed as follows:

- Unscrew the screw lid
- Remove used strainer insert upwards
- Slew suction filter vertically upwards
- Remove the suction filter
- Use a brush and clean oil to clean the suction filter
- Plug new suction filter fully onto the filter holder
- Slew suction filter into horizontal position
- Re-insert the strainer insert
- If necessary, fill pump via strainer insert with clean oil
- Position screw lid again and firmly tighten it

Now the suction filter has been cleaned.



Replace filters that are too much contaminated or damaged.

11.6 Interior cleaning of the oil reservoir

To clean the interior of the oil reservoir, proceed as follows:

- Drain the oil via the screw fitting into a suitable leakproof reservoir
- Unscrew the screw lid
- Remove used strainer insert upwards
- Use a brush and clean oil to clean the interior of the oil reservoir
- Close the screw cap
- Check the position of the suction filter
- Re-insert the strainer insert
- If necessary, fill pump via strainer insert with clean oil
- Position screw lid again and firmly tighten it

Now the interior of the oil reservoir is clean again.

12. Repair

12.1 Safety measures before carrying out repair works

Repair works may be performed by qualified and authorized personnel only by using original spare parts.

Before carrying out any repair work, take at least the following safety measures:

- Prevent access by unauthorised persons
- Mark the working area accordingly
- Disconnect the machine or system into which the product is or will be integrated from the power supply and secure it against unauthorized activation
- Disconnect the product from the power supply
- Protect the product against being switched on unintentionally
- Verify that no power is being applied
- Cover neighbouring units that are live
- If protective and safety equipment has to be dismantled, it must be reassembled immediately after finishing the work, and then be checked for correct function.

12.2 Replace strainer insert

To replace a strongly contaminated or damaged strainer insert, proceed as follows:

- Unscrew the screw lid
- Remove used strainer insert upwards
- Insert new strainer insert
- Position screw lid again and firmly tighten it

Now the strainer insert has been replaced.

Dispose of the used strainer insert.

12.3 Replace suction filter

Replacement after visual inspection during minimum filling level. If necessary, drain the oil via the screw fitting into a suitable leakproof reservoir and dispose of in an environment-friendly manner. Do not reuse drained oil.

To replace a strongly contaminated or damaged suction filter, proceed as follows:

- Unscrew the screw lid
- Remove used strainer insert upwards
- Slew suction filter vertically upwards (Fig. 21)
- Remove the suction filter
- Plug new suction filter fully onto the filter holder
- Slew suction filter into horizontal position
- Re-insert the strainer insert
- If necessary, fill pump via strainer insert with clean oil
- Position screw lid again and firmly tighten it

Now the suction filter has been replaced.

Dispose of the used suction filter.

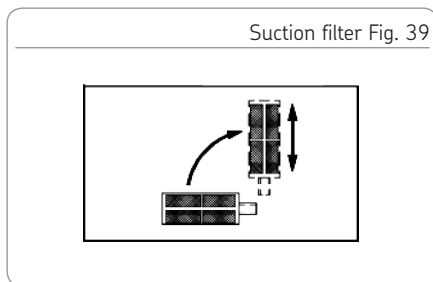

12.4 Replace pressure unit

12.4.1 Dismantle defective pressure unit

To dismantle the defective pressure unit, proceed as follows:

- Drain the oil via the screw cap into a suitable leakproof reservoir
- Close screw cap again
- Unscrew the screw lid
- Remove used strainer insert upwards
- Slew suction filter (9) into vertical position
- Remove suction filter upwards
- Mark the plug-in connector (14) and the hoses on the bottom side of the reservoir to avoid mixing up
- Loosen plug-in connector (AF 12, tightening torque $5 \pm 0.5\text{Nm}$)
- Firmly press hoses into plug-in connector
- Press outer ring of plug-in connector and keep it pressed
- Remove hoses
- Remove pressure unit (11) upwards (A)

- Firmly press the pressure line (26) into the plug-in connector(14) on the pressure unit
- Press outer ring of plug-in connector and keep it pressed
- Remove the pressure line (26)

The defective pressure unit has been dismantled.

Dispose of the pressure unit.

Loosen the plug-in connector Fig. 40

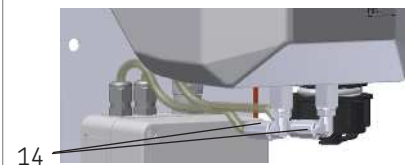

Loosen the plug-in connector Fig. 41

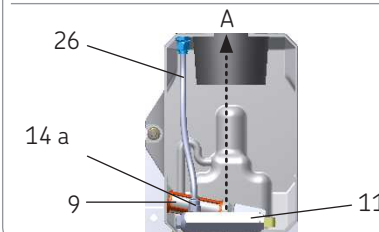

12.4.2 Install new pressure unit

To install the new pressure unit, proceed as follows:

- Press the pressure line (26) into the plug-in connector(4) on the new pressure unit (2)
- Grease the included gaskets on one side to protect them against falling out
- Insert gaskets with the greased side in the connectors on the bottom of the new pressure unit and check their position
- Position the new pressure unit properly in the oil reservoir
- Mount the plug-in connector (14) on the correct side of the bottom of the oil reservoir. (AF 12, tightening torque $5 \pm 0.5\text{Nm}$). Pay attention to the marking.
- Plug hoses into the correct side of the plug-in connector on the bottom of the oil reservoir.
- Position suction filter (9) on the new pressure unit and slew into horizontal position
- Insert the strainer insert
- Fill oil reservoir with clean oil
- Position screw lid again and firmly tighten it

The new pressure unit has been installed.

Before and during the restart-up carry out the checks described in the chapter Initial start-up.

13. Troubleshooting

Fault	Possible cause / apparent by:	Remedy
Pump does not run	<ul style="list-style-type: none"> ○ Power supply interrupted ○ Defective pump 	<ul style="list-style-type: none"> ○ Clarify power supply ○ Replace pump
Pump runs very noisily	<ul style="list-style-type: none"> ○ Oil reservoir empty ○ Slew suction filter into vertical position ○ Contaminated suction filter 	<ul style="list-style-type: none"> ○ Fill the reservoir (see chapter Initial start-up) ○ Slew suction filter into horizontal position (see chapter Maintenance) ○ Clean or replace suction filter (see chapter Cleaning / Repair)
Pump runs but builds up little or no pressure	<ul style="list-style-type: none"> ○ Lubrication lines contain air ○ Defective pressure unit 	<ul style="list-style-type: none"> ○ Vent the pump (see chapter Initial start-up) ○ Replace pressure unit (see chapter Repair)
No oil leaking from the lubrication point(s)	<ul style="list-style-type: none"> ○ Oil reservoir empty ○ Power supply interrupted ○ Leakages ○ Clogged lubrication point(s) 	<ul style="list-style-type: none"> ○ Fill the reservoir, vent the pump (see chapter Initial start-up) ○ Check the power supply ○ Check fittings and lines ○ Check the lubrication points
If the fault cannot be determined and remedied, please contact our Customer Service.		

14. Final shutdown and disposal

14.1 Temporary shutdown

Temporarily shut the system down by:

- Switching off the superior machine.
- Disconnecting the product from the power supply.

14.2 Final shutdown and disassembly

The final shutdown and disassembly of the product must be professionally planned and carried out by the operator in compliance with all regulations to be observed.

14.3 Disposal

Countries within the European Union

Disposal should be avoided or minimized wherever possible. Disposal of products contaminated with lubricant must be effected via a licensed waste disposal contractor in accordance with environmental requirements and waste disposal regulations as well as local authority requirements.



The specific classification of the waste is in the waste producer's responsibility, as the European Waste Catalogue provides different waste disposal codes for the same type of waste but of different origin.

Dispose of or recycle electrical components following WEEE directive 2012/19/EU.



Parts made of plastic or metal can be disposed of with the commercial waste.



Countries outside the European Union

The disposal has to be done according to the valid national regulations and laws of the country where the product is used.

15. Spare parts and accessories

The spare parts assemblies may be used exclusively for replacement of identical defective parts. Modifications with spare parts on existing products are not allowed.

15.1 Pump assy. EOP2-12

Designation	Qty.	Part number
<u>Pump assy. EOP2-12</u>	1	EOP2-04-05-1-1+912
consisting of:		
1 x 5 l reservoir with pump unit, mounted onto bracket		

15.2 Pump assy. EOP2-24

Designation	Qty.	Part number
<u>Pump assy. EOP2-24</u>	1	EOP2-04-05-1-1+924
consisting of:		
1 x 5 l reservoir with pump unit, mounted onto bracket		



15.3 Pressure unit assy.

Designation	Qty.	Part number
Pressure unit assy. including: Pressure control and pressure relief valve	1	552-32401-1

Fig. 43



15.4 Screw lid

Designation	Qty.	Part number
Screw lid	1	221-12488-5

Fig. 44



15.5 Suction filter

Designation	Qty.	Part number
Suction filter, PA66, 100 µm/PA66	1	235-10002-5

Fig. 45



15.6 Strainer insert

Designation	Qty.	Part number
Strainer insert, stainless steel, 500 µm	1	235-13189-1

Fig. 46



15.7 Connection cable

Designation	Qty.	Part number
Connection cable	1	664-34135-2

Fig. 47



15.8 Plastic tube

Designation	Qty.	Part number
Plastic tube	1	WVN715-Ro6x1

Fig. 48



15.9 Gaskets

Designation	Qty.	Part number
PA gasket	2	226-13780-6

Fig. 49



15.10 Adhesive label

Designation	Qty.	Part number
MIN/MAX label	1	810-55336-1

Fig. 50



15.11 Screw cap

Designation	Qty.	Part number
Screw cap with holding strap	1	221-12489-5

Fig. 51



15.12 Optional accessories

The spare parts assemblies may be used exclusively for replacement of identical defective parts. Modifications with spare parts on existing products are not allowed.

15.12.1 Quicklinc connectors for connecting metering elements, brushes and filling connections to the divider bar, plug-in type

Designation	Qty.	Part number
Straight screw-in fitting GEZ (18), Ø 4 mm, R1/8	1	226-10205-2
90° - elbow fitting WEK, Ø 4 mm, M8 x 1	1	226-13753-1



Fig. 28

15.12.2 Quicklinc connectors for EOP oil pump, reservoir and divider bars

Designation	Qty.	Part number
Straight screw-in fitting GEZ (20), Ø 8 mm, R1/8	1	226-13746-5
Bulkhead fitting (18), Ø 8 mm, G1/8	1	226-10214-1
90° - elbow fitting WEK, Ø 8 mm, R1/8	1	226-13776-3



Fig. 29

15.12.3 Closure plugs of the divider bar

Designation	Qty.	Part number
Closure plug for Quickline, Ø 4 mm	1	226-10238-1
Closure screw, R1/8	1	226-14160-3

Fig. 30



15.12.4 Brush

Designation	Qty.	Part number
Brush, M8 x 1	1	452-70233-1

Fig. 31



15.12.5 EOE metering elements

Designation	Qty.	Part number
Metering element assy. EOE, white, 0.3 ccm	1	552-32397-1

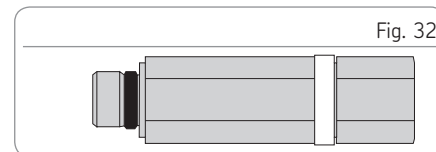

Designation	Qty.	Part number
Metering element assy. EOE, red, 0.3 ccm	1	552-32398-1

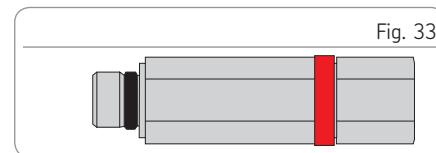

Designation	Qty.	Part number
Metering element assy. EOE, green, 0.4 ccm	1	552-32399-1

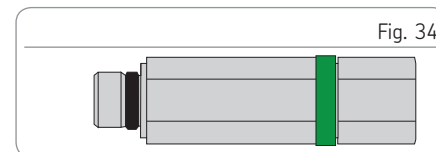

Designation	Qty.	Part number
Metering element assy. EOE, blue, 0.5 ccm	1	552-32400-1

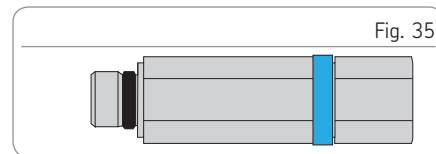

Designation	Qty.	Part number
Metering element assy. EOE, yellow, 1,0 ccm	1	552-32801-1

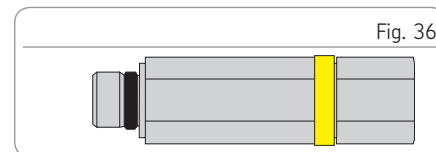

15.12.6 Divider bar

Designation	Qty.	Part number
Divider bar 2-fold 50 x 25 x 15	1	452-70235-1
Divider bar 3-fold 70 x 25 x 15	1	452-70236-1
Divider bar 4-fold 90 x 25 x 15	1	452-70237-1
Divider bar 5-fold 110 x 25 x 15	1	452-71284-1

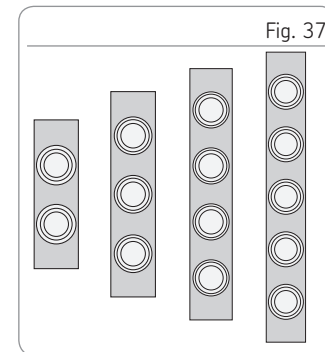

15.12.7 Tube clamp

Designation	Qty.	Part number
Tube clamp D12 with rubber sleeve for attaching the brush by means of a screw M5	1	226-12557-3

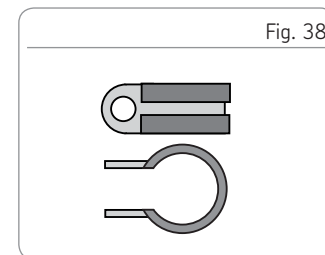

15.12.8 Feed lines

Designation	Qty.	Part number
PA12HL 8,0 x 1,0 black, sold by the metre	1	112-35255-4
PA12HL 4,0 x 0,65 black, sold by the metre	1	112-35255-3

Indicate the required length in your offer



15.12.9 Brackets and elbows

Designation	Qty.	Part number
Bracket	1	307-19543-1

Figures, see the following page

Designation	Qty.	Part number
Elbow	1	432-23982-1

Designation	Qty.	Part number
Elbow	1	810-260-020

Designation	Qty.	Part number
Elbow	1	881-280-006

Designation	Qty.	Part number
Elbow	1	881-130-026

Designation	Qty.	Part number
Elbow	1	881-290-110

<p>307-19543-1</p> <p>Technical drawing of part 307-19543-1. It consists of a rectangular plate with a width of 60 and a height of 65. There are four circular holes: two at the top with a center-to-center distance of 20, and two at the bottom with a center-to-center distance of 10.5. The top holes are 7 units from the top edge. The bottom holes are 16 units from the bottom edge. A bent flange is attached to the bottom edge, with a vertical leg of 38 units and a horizontal leg of 74 units. The flange has a thickness of 3 units and a radius of R3.</p>	<p>432-23982-1</p> <p>Technical drawing of part 432-23982-1. It consists of a trapezoidal plate with a top width of 28, a bottom width of 70, and a height of 70. There is a circular hole with a diameter of 17 units, centered 10 units from the bottom edge. A bent flange is attached to the bottom edge, with a vertical leg of 3 units and a horizontal leg of 30 units. The flange has a radius of R3,5.</p>	<p>810-260-020</p> <p>Technical drawing of part 810-260-020. It consists of a complex plate with a top width of 66 and a bottom width of 30. There are six circular holes arranged in two rows of three. The top row holes are 7 units from the top edge, and the bottom row holes are 8 units from the bottom edge. The center-to-center distance between holes in the top row is 11 units. A bent flange is attached to the right side, with a vertical leg of 63 units and a horizontal leg of 3 units. The flange has a radius of R4.</p>
<p>881-280-006</p> <p>Technical drawing of part 881-280-006. It consists of a rectangular plate with a width of 50 and a height of 30. There are three circular holes with a diameter of 7 units. The holes are positioned 29 units from the left edge and 9 units from the right edge. A bent flange is attached to the bottom edge, with a vertical leg of 35 units and a horizontal leg of 83 units. The flange has a radius of R3,5.</p>	<p>881-130-026</p> <p>Technical drawing of part 881-130-026. It consists of a rectangular plate with a width of 15 and a height of 10. There are two circular holes with a diameter of 6 units, positioned 10 units from the left edge. A bent flange is attached to the right side, with a vertical leg of 15 units and a horizontal leg of 3 units. The flange has a radius of R1,9.</p>	<p>881-290-110</p> <p>Technical drawing of part 881-290-110. It consists of a trapezoidal plate with a top width of 80, a bottom width of 200, and a height of 70. There are three circular holes with a diameter of 15 units. The holes are positioned 9 units from the top edge. A bent flange is attached to the right side, with a vertical leg of 70 units and a horizontal leg of 40 units. The flange has a radius of R3,5.</p>

951-171-012-EN

2017/10/25

Version 03

SKF Lubrication Systems Germany GmbH

Walldorf Facilities

Heinrich-Hertz-Str. 2-8

DE - 69190 Walldorf

Phone: +49 (0) 6227 33-0

Fax: +49 (0) 6227 33-259

E-mail: Lubrication-germany@skf.com

www.skf.com/lubrication

