

Fluid evacuator plus

Model MV7201

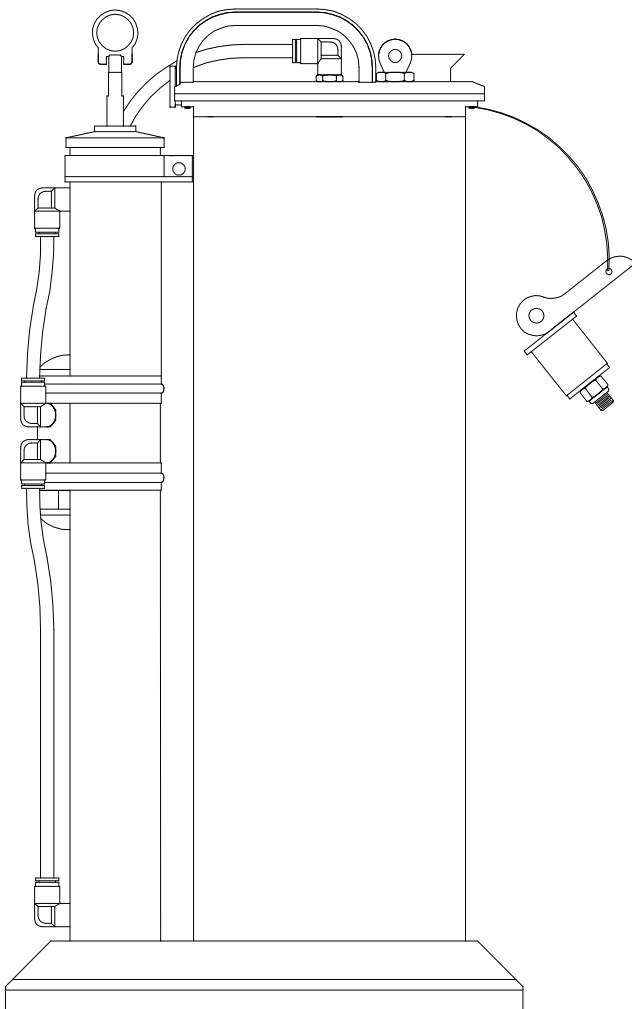

Date of issue	November 2017
Form number	801672
Version	2

Contents

Safety	2
Explanation of signal words for safety ..	2
Precaution	3
Automatic shut-off valve	3
Reservoir specifications	3
Extract from and dispense motor oil into crankcase	3
Extract from and dispense fluid into transmission cases and differentials	4
Extract and dispense coolant into cooling system	5
Extract brake fluid from master cylinder	5
Technical questions	5
Service parts	5
Illustrated parts break down	6
Model MV7201 service parts list	6

Safety

Read and carefully observe operating instructions before unpacking and operating pump. Pump must be operated, maintained and repaired exclusively by persons familiar with operating instructions. Local safety regulations regarding installation, operation and maintenance must be followed.
Operate pump only after safety instructions and this service manual are fully understood.

⚠ DANGER
Do not use with gasoline, diesel, kerosene or 2 stroke mixture.
Failure to comply may result in death or serious injury.

Explanation of signal words for safety

NOTE
Emphasizes useful hints and recommendations as well as information for efficient and trouble-free operation.

⚠ CAUTION
Indicates a dangerous situation that can lead to light personal injury or property damage if precautionary measures are ignored.

⚠ WARNING
Indicates a dangerous situation that can lead to death or serious injury if precautionary measures are ignored.

⚠ DANGER
Indicates a dangerous situation that will lead to death or serious injury if precautionary measures are ignored.

Precaution

Equipment is designed for servicing a variety of vehicles in a safe and convenient manner; however, differences in engine blocks and dip stick configurations make it impossible to use equipment on every vehicle.

Documented procedures are to serve as guidelines for general use of equipment. In addition to guidelines, always follow manufacturer's recommended procedures when attempting to use equipment on each unique vehicle.

Do not attempt to force tubes included with equipment into dip stick tube that does not readily accept smaller of two tubes.

Tubes that appear to be too large are not designed to be used with these particular vehicles.

Draining oil with evacuator unit through dipstick tube is expected to be simple and straightforward. Instructions are written as a general guideline only. Always read carefully and understand instructions prior to using equipment.

Tighten lid-to-reservoir screws before first use, and periodically after, to ensure proper seal.

⚠ WARNING

Do not adjust pressure relief valve. Build pressure by pumping at pumping rate of maximum 40 strokes per minute. Unit should not be pressurized by any other means.

Failure to comply may result in death or serious injury

Table 1

Reservoir specifications

Capacity	2.3 gallons (8.8 liters)
Maximum operating temperature	175 °F (80 °C)
Recommended fluids	Engine oil, gear and transmission oils, power steering fluid, coolants, brake fluid, and other similar fluids

Automatic shut-off valve

Reservoir tank of fluid evacuator plus is equipped with automatic shut-off valve to prevent over-filling of reservoir tank. As fluid flows into reservoir tank, float raises. When float reaches shut-off valve, flow of fluid being extracted automatically stops.

While automatic shut-off is in place it is not guaranteed to prevent overflow. Make sure the extractor is on a level surface and take caution to not overfill the unit.

NOTE

Do not force tube into crankcase. Stop inserting tube in if any force is recognized. Dealer should be contacted for detail on using equipment to evacuate oil from vehicle if issues arise.

Extract from and dispense motor oil into crankcase

- 1 Park vehicle on level ground.
- 2 Ensure transmission of vehicle is in *neutral* or *park* and apply parking brake.
- 3 Start engine.
- 4 Allow engine to idle until it reaches normal operating temperature. Once this is accomplished, turn engine off.

NOTE

Do not extract oil when temperature is above 176 °F (80 °C).

- 5 Remove engine oil dipstick.
- 6 Select and insert smallest diameter dipstick tube into dipstick hole until it reaches bottom of oil pan.
- 7 Connect main suction tube to dipstick tube.
- 8 Insert opposite end of main suction tube into 10mm x 90° tube connector on top of reservoir tank.

NOTE

Verify tube is in connector all the way to prevent leakage.

- 9 Place selector valve mounted on side of pump assembly to **evacuate**.
- 10 Raise pump handle on reservoir tank until highest limit is reached.
- 11 Pump handle approximately ten times. Unit will begin to extract oil from engine crankcase.

NOTE

It may be necessary to empty fluid reservoir tank and restart process if crankcase capacity exceeds 8 liters (2.11 gallons).

- 12 Once oil is extracted from crankcase, remove expandable rubber plug from reservoir tank.
- 13 Pour oil from tank into suitable container, and dispose of oil in appropriate manner.
- 14 Rinse out reservoir tank with clean solvent or engine degreaser. Allow to dry thoroughly.
- 15 If using fluid evacuator plus to dispense oil, fill cleaned reservoir tank with new oil and switch selector valve mounted on side of pump assembly to **dispense**.
- 16 Pull up on pump handle and begin pumping until engine crankcase is filled to desired level.
- 17 Run engine momentarily to circulate new oil and then re-check level.

Extract from and dispense fluid into transmission cases and differentials

- 1 Follow steps 1 and 2 above in *Extract and dispense motor oil into a crankcase*.
- 2 Remove transmission fluid dipstick or fill plug.
- 3 Select and insert appropriate diameter dipstick tube into dipstick fill hole until it reaches bottom of transmission pan or gear case.

WARNING

In some applications this may require jacking or lifting vehicle. Use appropriate safety stands to avoid serious or fatal injury.

- 4 Connect main suction tube to dipstick tube.
- 5 Insert opposite end of main suction tube into 10mm x 90° tube connector on top of reservoir tank.

NOTE

Verify tube is in connector all the way to prevent leakage.

- 6 Place selector valve mounted on side of pump assembly to **evacuate**.
- 7 Raise pump handle on reservoir tank until highest limit is reached. Pump handle approximately ten times. Unit will begin to extract transmission fluid from transmission.
- 8 Once transmission fluid has been extracted, remove expandable rubber plug from reservoir tank.
- 9 Pour transmission fluid from tank into suitable container, and dispose of transmission fluid in an appropriate manner.
- 10 Rinse out reservoir tank with clean solvent or engine degreaser. Allow to dry thoroughly.
- 11 If using fluid evacuator plus to dispense transmission fluid, fill cleaned reservoir tank with new transmission fluid and simply switch selector valve mounted on the side of pump assembly to **dispense**.
- 12 Pull up on pump handle and continue pumping until the transmission is filled to the desired level.
- 13 Follow operating instructions for vehicle to properly check transmission fluid level.

Extract and dispense coolant into cooling system

⚠ WARNING

Never remove cap from radiator or expansion tank while engine is at operating temperature. Always allow engine to cool before removing radiator cap or expansion tank cap. Cooling system is under pressure. Failure to allow engine to cool before attempting to remove cap could result in death or serious injury.

- 1 Allow engine to cool.
- 2 Remove radiator/expansion tank cap.
- 3 Select largest diameter dipstick tube and insert tube into radiator neck or expansion tank.
- 4 Insert opposite end of main suction tube into 10 mm x 90° tube connector on top of reservoir tank.

NOTE

Verify tube is in connector all the way to prevent leakage.

- 5 Place selector valve mounted on side of pump assembly to **evacuate**.
- 6 Raise pump handle on reservoir tank until highest limit is reached. Pump handle approximately ten times. Unit will begin to extract coolant from cooling system.
- 7 Once coolant has been extracted, remove expandable rubber plug from reservoir tank.
- 8 Pour coolant from tank into suitable container, and dispose of it in appropriate manner.
- 9 Rinse out reservoir tank with clean solvent or engine degreaser. Allow to dry thoroughly.
- 10 If using fluid evacuator plus, fill cleaned reservoir tank with new coolant and switch selector valve mounted on side of pump assembly to **dispense**.
- 11 Pull up on pump handle and continue pumping until cooling system is filled to desired level.
- 12 Be sure to run engine until it reaches operating temperature to circulate new coolant and then re-check level to verify it is full.

Extract brake fluid from master cylinder

- 1 Clean exterior of master cylinder and master cylinder cap. This will prevent dirt from entering master cylinder reservoir when cap is removed.
- 2 Remove lid of master cylinder reservoir.
- 3 Select appropriate dipstick tube and connect it to main suction tube.

⚠ WARNING

Prior to inserting extraction tube into master cylinder reservoir, be sure extraction tube is clean and free of any other types of fluid. Failure to do so would result in contamination of brake fluid in hydraulic system and cause potential brake failure.

- 4 Insert opposite end of main suction tube into 10mm x 90° tube connector on top of reservoir tank.

NOTE

Verify tube is in connector all the way to prevent leakage.

- 5 Place selector valve mounted on side of pump assembly to **evacuate**.
- 6 Insert end of extraction tube into master cylinder reservoir.
- 7 Raise pump handle on reservoir tank until highest limit is reached.
- 8 Pump handle approximately ten times. Unit will begin to extract brake fluid from master cylinder reservoir.
- 9 Once brake fluid has been extracted, remove expandable rubber plug from reservoir tank.
- 10 Pour brake fluid from tank into suitable container and dispose of it in appropriate manner.
- 11 Rinse out reservoir tank with clean solvent or engine degreaser. Allow to dry thoroughly.
- 12 After all repairs are accomplished, refill system with new, manufacturer approved brake fluid from sealed container.

Technical questions

If you have questions, or require technical service, please contact trained service technicians at: 1-314-679-4200 ext. 4782.

Visit website www.mityvac.com for new products, catalogs and instructions for product use.

Service parts

To order replacement or service parts, visit www.mityvacparts.com or call toll free 1-800-992-9898.

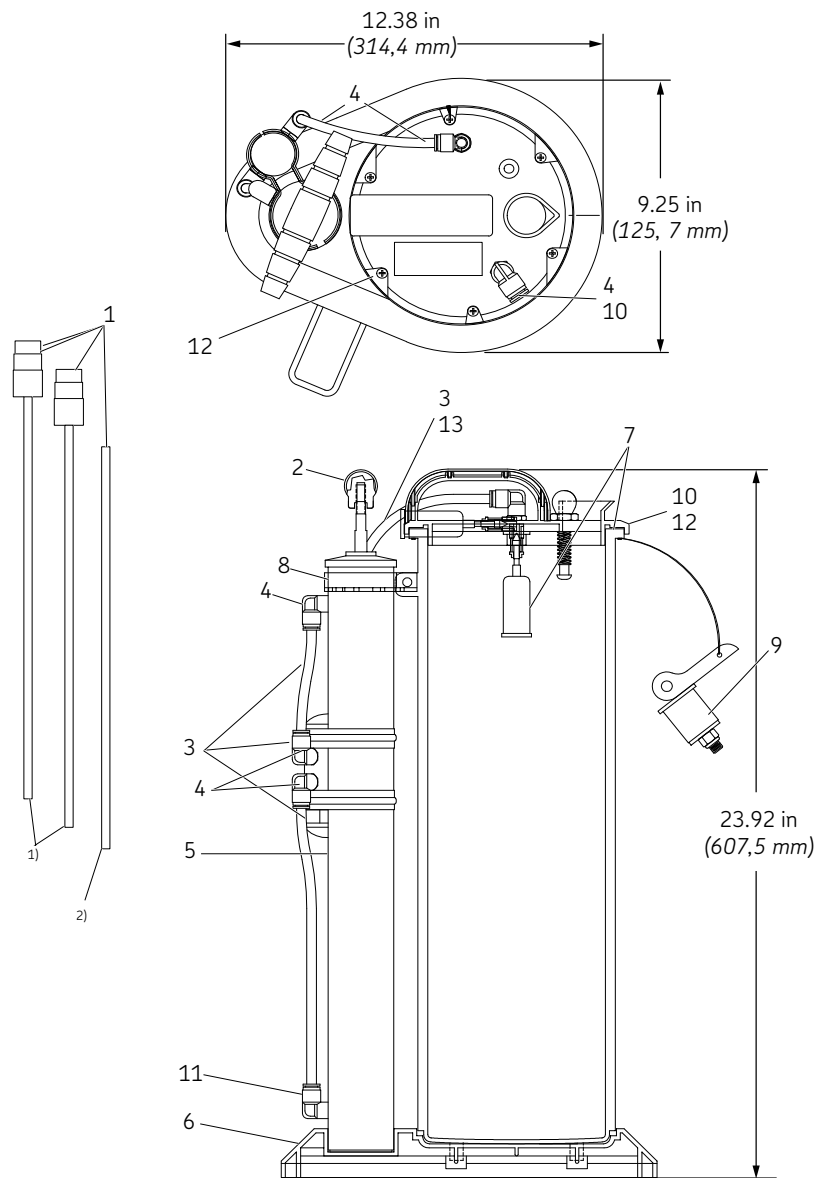

- 1) Dipstick tubes.
- 2) Main suction tube.

Model MV7201 service parts list

Item	Description	Part no.	Item	Description	Part no.
1	Vacuum tube kit	822559	7	Evacuator top kit ⁵⁾	822576
2	Handle kit	822561	8	Pump strap kit	822578
3	Valve kit ¹⁾	822563	9	Expandable plug kit	822593
4	Tube connector kit ²⁾	822566	10	Top seal kit	822821
5	Pump assembly kit ³⁾	822572	11	Tube connector with check kit	822998
6	Base kit ⁴⁾	822574	12	Field service kit ⁶⁾	MVM9000
			13	Replacement tube	801671

- ¹⁾ Consists of three tubes, three 8 mm connectors and valve.
- ²⁾ Consists of three 8 mm connectors and three 10 mm connectors.
- ³⁾ Consists of two 8 mm connectors, two tubes and pump assembly.

- ⁴⁾ Consists of base and foot bracket.
- ⁵⁾ Consists of top and overflow float.
- ⁶⁾ Consists of top seal, six locknuts, 10 mm connector, and six M5 screws.

This page left intentionally blank.

skf.com | mityvac.com

® SKF and MityVac are registered trademarks of the SKF Group.

© SKF Group 2017

The contents of this publication are the copyright of the publisher and may not be reproduced (even extracts) unless prior written permission is granted. Every care has been taken to ensure the accuracy of the information contained in this publication but no liability can be accepted for any loss or damage whether direct, indirect or consequential arising out of the use of the information contained herein.

November 2017 · Form 801672 Version 2