

IG502-2-E

Universal Control Unit

For use in centralized lubrication systems
for commercial vehicles



Owners Manual
Version 04

WARNING:

Read this owner's manual before installing, operating or maintaining the product. Failure to follow the instructions and safety precautions in this owner's manual could result in serious injury, death, or property damage. Keep for future reference.



Masthead

This owner's manual - containing installation, operation and maintenance instructions is an integral part of the described product. It must be kept for future use.

This owner's manual - containing installation, operation and maintenance instructions was created in accordance with the valid standards and regulations on documentation, VDI 4500 and EN 292.

© SKF Lubrication Systems Germany GmbH

This documentation is protected by copyright. The photomechanical reproduction, copying, and distribution of this documentation or parts thereof by means of processes such as data processing, data carriers, and data networks is strictly prohibited without the express permission of SKF Lubrication Systems Germany GmbH.

SKF Lubrication Systems Germany GmbH reserves the right to make content and technical changes.

Universal Control Unit IG502-2-E

Keep for future use!

Replaces also the following earlier models:

IG471-21
IG472-11
IG434-1
IG472-22
IG433-5-51

CE marking:

All relevant products of SKF Lubrication Systems Germany GmbH are labelled with the CE marking.

Content

Masthead.....	2	7 Modes of operation.....	18	10 Faults.....	32
1 Safety.....	4	7.1 Timer operation (setting pause and pump running times)	18	10.1 Display faults	32
1.1 Use in conformity with intended purpose	4	7.2 Counter operation (pause depends on number of impulses)	18	10.2 Clear fault message	32
1.2 Danger caused by electrical current	4	7.3 Special control variants	18	10.3 Block operation	33
1.3 Approved personnel	4	7.4 Operation without system monitoring	18	10.4 Delayed signal from cycle switch	33
1.4 Exclusion of liability.....	4	7.5 Operation with system monitoring.....	18	10.5 No signal from cycle switch	34
2 IG502-2-E view of unit.....	5	7.6 Monitoring with pressure switch	19	10.6 No signal from pressure switch	34
2.1 Range of applications.....	5	7.7 Monitoring with cycle switch	20	10.7 Storage of fault times	34
3 Installation.....	6	8 Pneumatic pump control.....	21	11 Maintenance and repair	35
3.1 Electrical connections.....	6	8.1 Operation without electronic monitoring of system.....	21	12 Technical data	35
4 Display and control panel	7	8.2 Operation with electronic monitoring of system.....	21	13 Service.....	36
4.1 Three-digit LED display	8	9 Use as replacement unit	22	14 Annex: Table.....	37
4.2 Display of functions via LEDs	10	9.1 Factory settings on IG502-2-E	22	15 EC Declaration of Conformity.....	38
4.3 Functions of operating keys	10	9.2 Replacing the previous model	22		
4.4 External signal lamp SL	10	9.3 Replacement of other control units.....	22		
5 Display mode	11	9.4 Replacing IG471-21	23		
6 Programming.....	13	9.5 Replacing IG472-11	25		
6.1 Starting the programming mode.....	13	9.6 Replacing IG434-1	27		
6.2 Changing the pause or pump running times	13	9.7 Replacing IG472-22.....	29		
6.3 Changing the system monitoring settings	15	9.8 Replacing IG433-5-51.....	31		
6.4 Changing the operating modes	16				
6.5 Changing the code	17				
6.6 Programming ranges.....	17				
6.7 Display areas.....	17				

1 Safety

The components are designed and manufactured in conformity with the generally accepted engineering standards as well as applicable industrial safety and accident prevention regulations. Though constructed to meet all relevant safety requirements, their use may still entail dangers leading to personal injury of the user or third parties or damage to property. Therefore, the components shall only be used when they are in a technically perfect condition, the operating instructions having to be duly observed. Any faults, in particular faults which may affect safety, shall be rectified without delay.



Texts marked with this symbol contain information on special dangers or important operations and works.

1.1 Use in conformity with intended purpose

The unit described herein is designed exclusively for controlling and monitoring SKF centralized lubrication systems. Therefore, it may be used exclusively for the purpose specified in this manual. The user himself shall be liable for any improper use and the damage resulting there from.

1.2 Danger caused by electrical current

The units may be connected to the power supply exclusively by appropriately trained qualified personnel in conformity with the local connection conditions and regulations (e.g. DIN, VDE)! Improperly connected equipment may lead to serious personal injury and damage to property!

The control unit is designed for use in battery powered on-board electrical systems of vehicles and construction machines. When used for any other purposes, all applicable safety regulations shall be complied with.

1.3 Approved personnel

The components described in this manual may be installed, operated, maintained and repaired only by qualified personnel. Qualified personnel means persons trained, assigned and instructed by the operator of the equipment concerned. These persons are familiar with the applicable norms, rules, accident prevention regulations and operating conditions on account of their training, experience and the instructions received. They are entitled to carry out the activities required in a given case and will be able to recognize and avoid possibly existing dangers.

DIN VDE 0105 or IEC 364 contains the definitions for specialists and the prohibition to use unqualified personnel.

1.4 Exclusion of liability

SKF Lubrication Systems Germany GmbH will not assume liability for damage:

- occurred due to lack of lubricant
- caused by soiled or improper lubricant
- caused due to the installation of non-original
- SKF components or SKF spare parts
- caused due to any use non-compliant with the
- intended purpose
- due to faulty installation and filling
- due to wrong electrical connection
- due to wrong programming
- due to improper reaction to failures

2 IG502-2-E view of unit

2.1 Range of applications

The universal control unit IG502-2-E is designed for the control and monitoring of centralized lubrication systems of commercial vehicles. The functions of the control unit can be programmed.

! For the replacement of previous SKF control units, see annex, page 37 or section 9.

A film protects the control elements from humidity and dirt. The unit has a data memory which is independent of the supply voltage. It is used for storing configuration data and parameters. As a result, the control unit does not require an uninterrupted voltage supply.

If an external signal lamp SL has been installed in the driver's cabin, it will light for 3s after the ignition is activated.

! The IG502-2-E unit is available in two versions, 12 V DC (IG502-2-E+912) or 24 V DC (IG502-2-E+924).

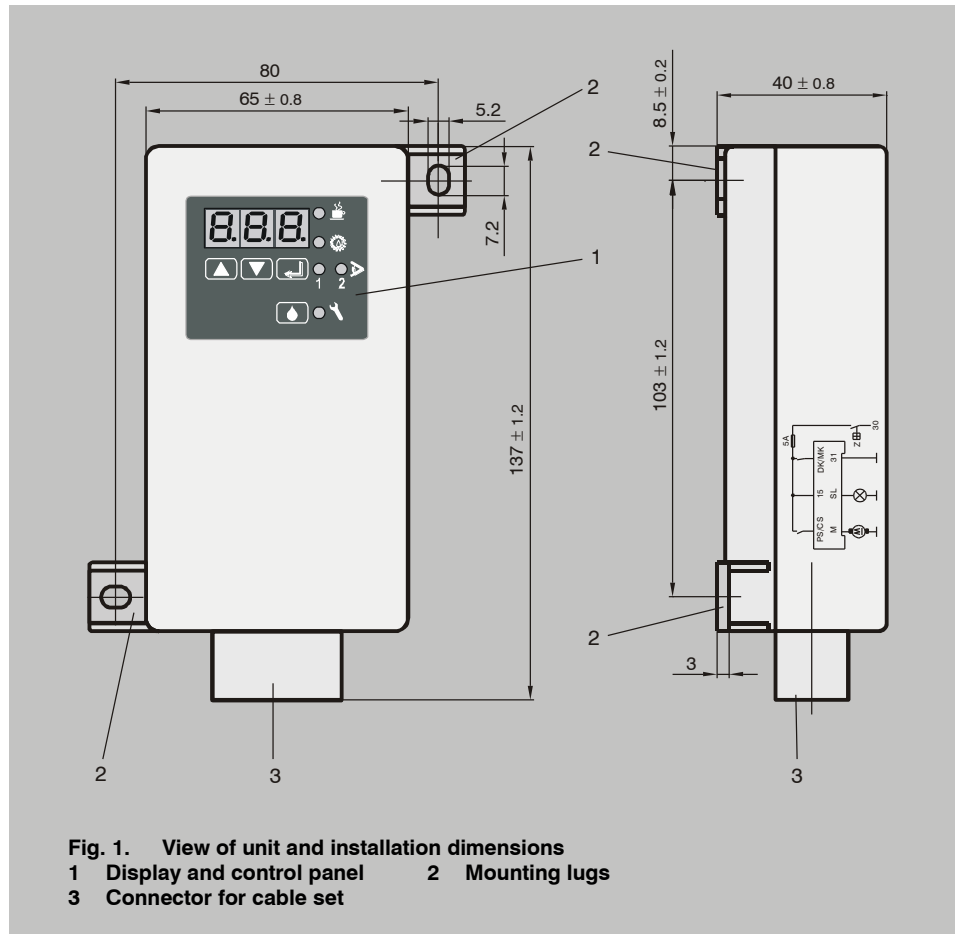

Fig. 1. View of unit and installation dimensions

- 1 Display and control panel 2 Mounting lugs
3 Connector for cable set

3 Installation

Install the unit within an enclosed compartment of the vehicle so that it is protected from environmental influences. Use the lugs on the unit for mounting it in a suitable place.

The IG502-2-E is accommodated in a housing of type of protection IP 20. The connector is of class of protection IP 00.

If the control unit is mounted at an inaccessible position, it is advisable to install an additional illuminated pushbutton on the dashboard as a fault indicator and functional control element (see Fig. 5).

The accessories required for the lubrication system such as the cable set, cycle or pressure switch can be seen from the SKF catalogue 1-9420, 1-9430.

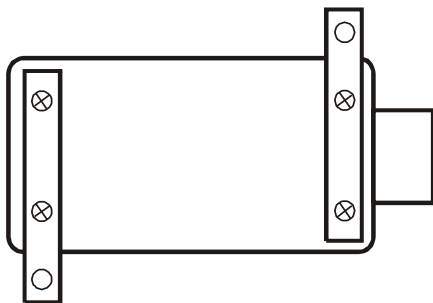

Fig. 2. Mounting lugs

3.1 Electrical connections

- PS/CS pressure or cycle switch
- 15 plus pole on-board system
- +M pump motor
- +SL external signal lamp
- DK/MK external pushbutton (timer operation)
- counter input (counter operation)
- 31 ground
- Z ignition lock

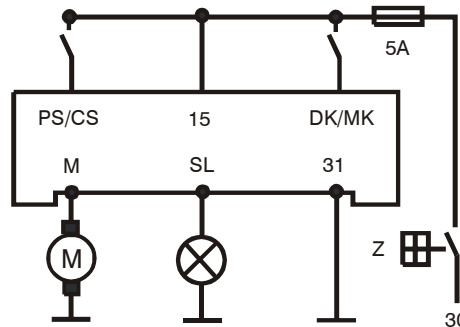

Fig. 3. Terminal connection diagram

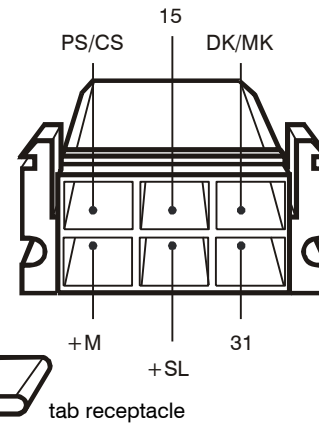

Fig. 4. Cable set receptacle housing

Order No.: 177-100-065

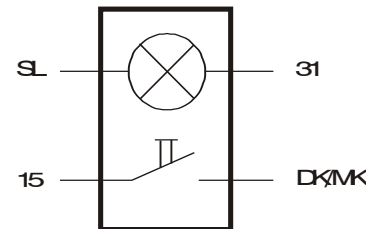

Fig. 5. Electrical connection of external illuminated pushbutton

4 Display and control panel

The display layout has been changed since 2007. For a better understanding, Table 1 shows the symbols of the new display, compared with the inscription of the old front panel foil.

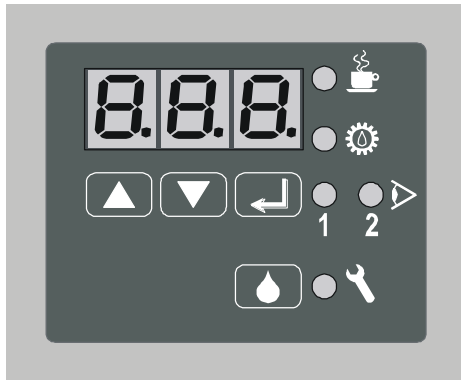

Fig. 6. Display and control panel

Table 1. Elements of the display and control panel

Description		Designation	Function
New display	Old display		
		Three-digit LED display	Values and operating state
	<input type="radio"/> PAUSE h/Imp	PAUSE-LED	Pause time
	<input type="radio"/> CONTACT min/Imp	CONTACT-LED	Displays contact time (pump operation)
	<input type="radio"/> CS	CS-LED	Monitoring of system function with an external cycle switch
	<input type="radio"/> PS	PS-LED	Monitoring of system function with an external pressure switch
	<input type="radio"/> FAULT	FAULT-LED	Fault message
		UP- resp. DOWN- Key	<ul style="list-style-type: none"> • Activate display • Display values and parameters • Set values and parameters
	SET	SET-Key	<ul style="list-style-type: none"> • Change over between programming and display mode • Confirm values
	DK	DK-Key	<ul style="list-style-type: none"> • Activate intermediate lubrication • Clear fault message

4.1 Three-digit LED display



During normal operation, the display is deactivated. To activate it, briefly press one of the two keys  . The unit displays current values and preset parameters. In addition, the display serves for guiding the operator during the programming of operating parameters.

Table 2. Three-digit LED display



Display	Denotation	Explanation	Control function
t P A	t = TIMER PA = PAUSE	The control unit operates as a time-controlled contact maker (TIMER) and is in the PAUSE state	Part of lubrication cycle Input and display value in hours
c P A	c = COUNTER PA = PAUSE	The control unit operates as a contact counter (COUNTER) and is in the PAUSE state	Part of lubrication cycle The unit counts the impulses from the external contact maker and compares them with the preset values
t C O	t = TIMER CO = CONTACT	The control unit operates as a time-controlled contact maker (TIMER) and is in the pump running time (CONTACT)	CONTACT = time during which the pump is delivering Input and display value in minutes
c C O	c = COUNTER CO = CONTACT	The control unit operates as a contact counter and is in the pump running time (CONTACT)	CONTACT = time during which the pump is delivering Input and display value in impulses
C O P	C = cycle O = OFF P = Pressure	Display of beginning of menu "Monitoring settings"	
O F F	Monitoring OFF	The monitoring function PS and CS is deactivated	No system monitoring
C S	Cycle Switch	Cycle switch monitoring is activated	During the pump running time CONTACT, the cycle switch is monitored for the transmission of signals
P S	Pressure Switch	Pressure switch monitoring is activated	During the pump running time CONTACT, the pressure switch is monitored for the transmission of signals.

Table 2 continued

Display	Denotation	Explanation	Control function
FLL	Fault Low Level	The minimum level in the reservoir has been reached	The control unit is in the FAULT state. The execution of functions is disabled.
FCS	Fault Cycle Switch	No signal from the cycle switch is received during the pump running time	The control unit is in the FAULT state. The execution of functions is disabled.
FPS	Fault Pressure Switch	No signal from the pressure switch is received during the pump running time	The control unit is in the FAULT state. The execution of functions is disabled.
Oh	Operation Hour Meter	The values subsequently displayed are the operation hours of the control unit.	
Fh	Fault Hour Meter	The values subsequently displayed is the time in hours for which the control unit has been operated in the FAULT state.	
blo	Block operation	No signal is received from the cycle switch. The control unit is still in the monitoring mode instead of the normal mode of operation. If the fault continues to be active through 3 pump running times, a fault message is displayed.	

4.2 Display of functions via LEDs

Table 3. Display of functions via LEDs

LED	LED lights = display mode	LED flashes = programming mode
	Operating voltage is applied to pump unit and control unit. The system is in the PAUSE state	The value for PAUSE may be changed.
	Operating voltage is applied to pump unit and control unit. The system is in the CONTACT state (pump motor ON)	The value for CONTACT may be changed.
1	A cycle switch is used for monitoring the system. Monitoring takes place at the progressive feeder during running of the pump. (CONTACT)	The monitoring function can be changed in the programming mode or deactivated. The cycle switch is operated by the piston of the distributor to be monitored.
2	A pressure switch is used for monitoring the system. Monitoring takes place during running of the pump. (CONTACT)	The monitoring function can be changed in the programming mode or deactivated. The pressure switch is operated by the pressure in the main line.
	The operating voltage is applied to the pump unit and control unit. The control unit is in the FAULT state. The cause may be determined via the LED display and displayed as a fault code after the operation of the button. The execution of functions is disabled.	





4.3 Functions of operating keys

4.4 External signal lamp SL

If an external signal lamp SL has been installed in the driver's cabin, this lamp will light up for 3s on switching on the ignition.

For connection of signal lamp, see page 6.

Table 4. Functions of operating keys

Key	Function
	Operating the button during PAUSE will initiate an intermediate lubrication cycle Fault messages are acknowledged and cleared
	Automatic activation of display in the display mode Call up next parameter in the programming mode Increase displayed value by 1
	Automatic activation of display in display mode Call up next parameter in programming mode Decrease displayed value by 1
	Change over between programming and display mode Confirm entered values

5 Display mode

Lighting of the LED indicators shows that the display mode is active. **No flashing!** This mode is used to determine which settings and operating parameters are currently active.

Always start the display mode by briefly pressing one of the two keys  .

Table 5. Display mode















Step	Key	Display	
1	  Press briefly.		Current operating state is displayed Example: pause time in timer mode
2			Display of remaining pause time of current lubrication cycle Example: 6,8 h
3			Display of preset total pause time Example: 9 h (factory setting)
4			Display of pump running time Example: Timer mode
5			Example: System is in pause mode, current tCO cannot be displayed
6			Display of preset value Example: 2,6 min
7			Display of system monitoring

Table 5 continued





Step	Key	Display
8		<p>Monitoring via pressure switch(factory setting) or Monitoring via cycle switch or Monitoring function disabled</p>
9		<p>Display of operation hours</p>
10/11		<p>Example: Note down part 1 of total value Part 2 of total value Added-up value: 533.8 h Maximum value: 99999.9 h</p>
12		<p>Display of fault hours</p>
13/14		<p>Example: Note down part 1 of total value! Part 2 of total value Added-up value: 33.8 h Maximum value: 99999.9 h</p>
15		<p>Display goes out Oh and Fh values are indelibly stored in the EEPROM.</p>

6 Programming

6.1 Starting the programming mode

- Flashing of the displays indicates that programming mode is active.

Table 6. Starting the programming mode

Step	Key	Display	
1	 Press for more than 2s		Display flashes (Code 000 factory setting)
2	 Press briefly (to confirm code)		Pause time in timer mode LED "Pause" flashes

6.2 Changing the pause or pump running times

Table 7. Changing the pause or pump running times































Step	Key	Display	
1	 Press for more than 2s		Display flashes (Code 000 factory setting)
2	 Press briefly (to confirm code)		Pause time in timer mode LED "Pause" flashes
3	 Press briefly		Pause time 9 h (factory setting)
4	 		Set new value Example: 6,8 h

Table 7 continued

Step	Key	Display	
5	 Press briefly (to confirm new value)		Pump running time in timer mode LED "Contact" flashes
6	 Press briefly		Pump running time 2,6 min (factory setting)
7			Set new value Example: 3 min
8	 Press briefly	To confirm new setting	
9	 Press for more than 2s	New settings are saved to the memory, display goes out.	













6.3 Changing the system monitoring settings

Table 8. Changing the system monitoring settings

Step	Key	Display	
1	 Press for more than 2s		Display flashes (Code 000 factory setting)
2	 Press briefly (to confirm code)		Pause time in timer mode LED "Pause" flashes
3	 Press until:		Beginning of monitoring settings is displayed
4	 Press briefly		Monitoring via pressure switch (factory setting)
5	  Operate appropriate key until	 Monitoring via cycle switch is set LED "CS" flashes	 or system monitoring OFF is displayed
6	 Press briefly	To confirm new setting	
7	 Press for more than 2s	New settings are saved to the memory, display goes out.	

6.4 Changing the operating modes

Table 9. Changing the operating modes

Step	Key	Display	
1	 Press for more than 2s		Display flashes (Code 000 factory setting)
2	 Press briefly (to confirm code)		Pause time in timer mode LED "Pause" flashes
3			Changing over the pause mode to counter operation is possible only with an external transmitter Values in impulses
4	 Press briefly to confirm counter operation		Display of pump running time in timer mode
5			Changing over of pump running time to counter operation For special application, see section 7.3
6	 Press briefly	to confirm new settings	
7	 Press for more than 2s	New settings are saved to the memory, display goes out.	

6.5 Changing the code

! **The code set by the factory has now been cleared, and the new value is valid. Note down the new value and keep it in a safe place. If you forget your code, parameters can no longer be programmed. In such a case, the control unit has to be returned to the manufacturer for re-coding.**

6.6 Programming ranges

Table 11. Programming ranges













Function	Programming ranges
Pause time	0,1 h to 99,9 h
Pump running time	0,1 min to 99,9 min
Impulses	1 to 999

6.7 Display areas

Table 12. Display areas

Function	Display areas
Pause time	0,1 h to 99,9 h
Pump running time	0,1 min to 99,9 min
Impulses	1 to 999
Error hours	0,1 h to 99999,9 h
Operating hours	0,1 h to 99999,9 h

Table 10. Changing the code

Step	Key	Display	
1	 Press for more than 2s		Display flashes (code 000 factory setting)
2	 Operate appropriate key until		Code number is displayed (321 = factory setting)
3	 Press briefly (to confirm code)		Display flashes
4	 Press briefly (to confirm old code)		Display flashes (code 000 factory setting)
5	 Operate appropriate key until		Desired new code is set Example: 666
6	 Press briefly	To confirm new code	
7	 Press for more than 2s	New code is saved to memory, display goes out.	

7 Modes of operation

7.1 Timer operation (setting pause and pump running times)

Perform settings in the programming modes tPA and tCO.

The control of the lubrication cycle takes place based on the values preset for the PAUSE and CONTACT times.

PAUSE: Display and programming values in **hours**

CONTACT: Display and programming values in **minutes**

With the key , intermediate lubrication cycles are activated and/or fault messages acknowledged and cleared. An external pushbutton can be connected to terminal DK/MK.

7.2 Counter operation (pause depends on number of impulses)

Perform settings in the programming modes cPA and tCO. See section 6.4. Connect an external impulse transmitter to input DK/MK.

PAUSE: Display and programming values in **impulses**

CONTACT: Display and programming values in **minutes**

The external transmitter controls the idle time as a function of machine movements. The pump running time (tCO) is programmed in minutes.

7.3 Special control variants

The pump running time is controlled as a function of the number of revolutions of the pump motor.

CONTACT: Display and programming values in **impulses.**

PAUSE: Display and programming values in **impulses or hours.**

Possible combinations: **tPA+ cCO**
cPA+ cCO

 **These operating modes can be used only in connection with pump units featuring level monitoring W1.**

7.4 Operation without system monitoring

In this mode of operation, the lubrication cycle is controlled only by the values set for PAUSE and CONTACT. The IG502-2-E is programmed by the manufacturer for system monitoring via a pressure switch.

 **The monitoring function must be disabled. COP = OFF (see section 6.3). System faults are not automatically detected and displayed.**

7.5 Operation with system monitoring

In this mode of operation, the functions of the system are additionally monitored by external switches.

The following functions can be monitored:

- the level in the lubricant reservoir (only for pumps featuring level monitoring W1)
- the pressure build-up in the main line by means of a pressure switch (section 7.6)
- the function of the progressive feeder by means of a cycle switch (section 7.7)

! Faults are automatically detected and displayed. The monitoring function is active. COP = CS or PS (see section 6.3). An installed level monitoring facility W1 is always active.

7.6 Monitoring with pressure switch

! Only in centralized lubrication systems for greases of NLGI classes 00 and 000!

The IG502-2-E is programmed by the manufacturer for monitoring of the system via a pressure switch.

COP = PS

If the monitoring function has been disabled, see section 6.3

If possible, the pressure switch should be installed downstream of the last distributor in the main line. It monitors the pressure build-up in the system during the CONTACT time.

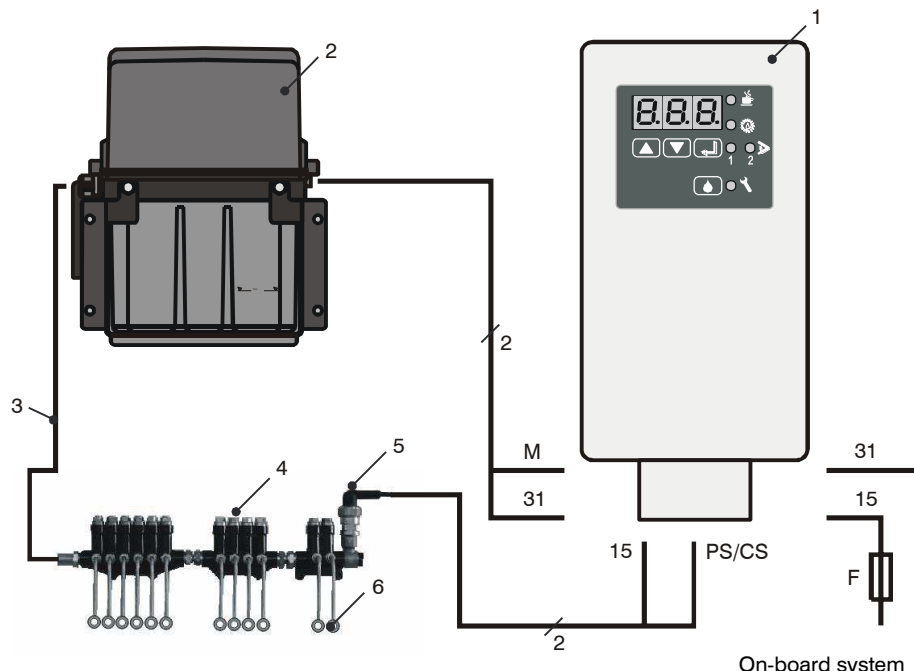

Fig. 7. Installation and electrical connection of pressure switch

- 1 Control unit IG502-2-E
- 2 Pump unit with lubricant reservoir
- 3 Main line
- 4 Distributor
- 5 Pressure switch
- 6 Friction points

7.7 Monitoring with cycle switch

! **May be used only in centralized lubrication systems featuring progressive feeders. For greases up to NLGI class 2.**

The cycle switch is used for monitoring the movement of the pistons in the progressive feeder during the CONTACT time. In the programming mode, the following monitoring function must be activated
COP = CS (see section 6.3).

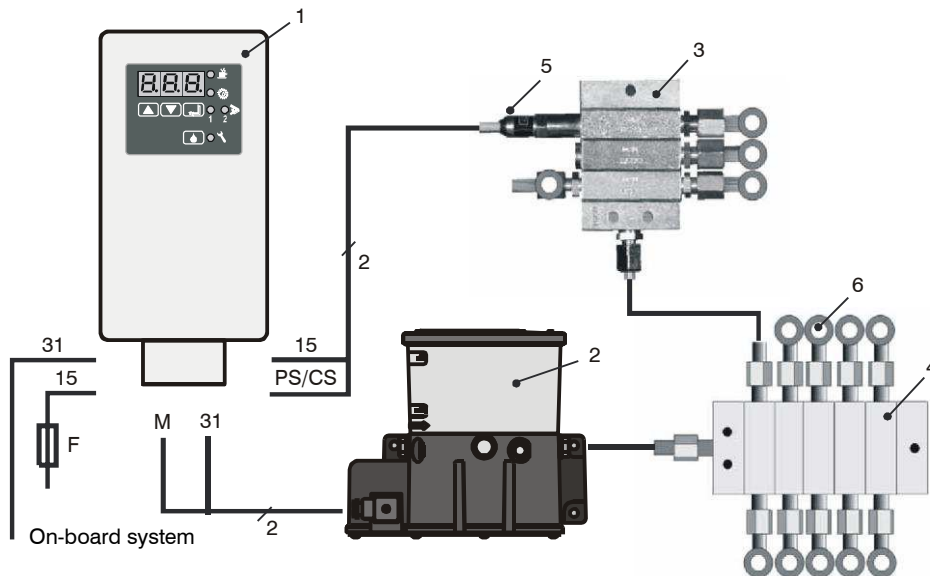

Fig. 8. Installation and electrical connection of cycle switch

- 1 Control unit IG502-2-E
- 2 KFG... pump with lubricant reservoir
- 3 Progressive feeder
- 4 Progressive feeder
- 5 Cycle switch
- 6 Friction points

8 Pneumatic pump control

! Only for centralized lubrication systems using greases of NLGI classes 00 and 000!

The pneumatic pump is controlled via a 3/2-way valve which effects the pressure relief for the pump during the pause time.

8.1 Operation without electronic monitoring of system

! System faults are not automatically detected and displayed. Monitoring function is disabled.
COP = OFF (see section 6.3).

8.2 Operation with electronic monitoring of system

The pressure switch should preferably be installed downstream of the last distributor in the main line. It monitors the pressure build-up in the system during the CONTACT time. Monitoring mode is active.
COP = PS (factory setting, see section 6.3).

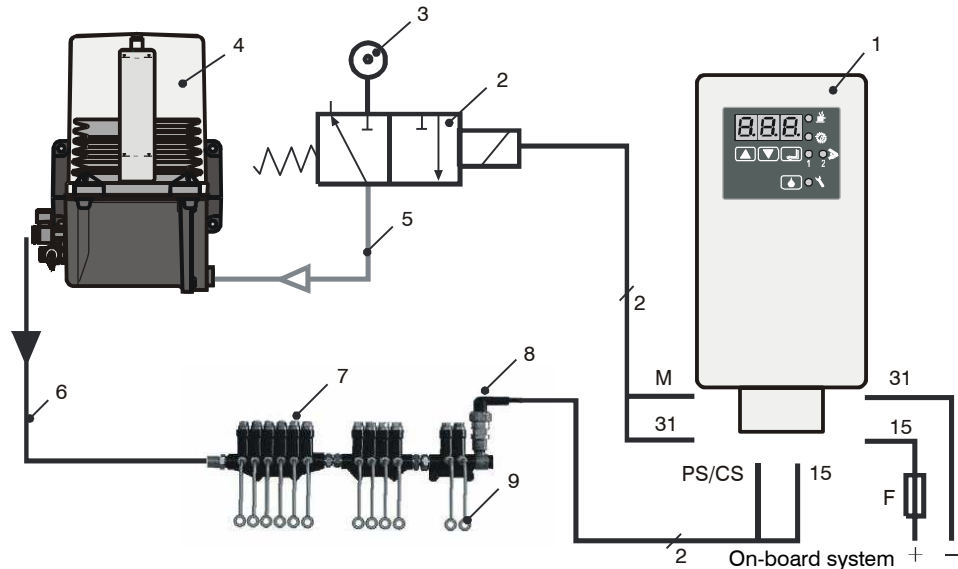

Fig. 9. Connection of pneumatic pump PEF 90 with system monitoring (

- 1 Control unit IG502-2-E
- 2 3/2-way valve
- 3 Pneumatic unit
- 4 Pneumatic pump, e.g. PEF 90
- 5 Pneumatic line
- 6 Lubrication line
- 7 Distributor
- 8 Pressure switch
- 9 Friction points

9 Use as replacement unit

The universal control unit IG502-2-E is designed for the control and monitoring of centralized lubrication systems of commercial vehicles. The functions of the IG502-2-E unit can be programmed so that it replaces a number of previous control unit models.

9.1 Factory settings on IG502-2-E

IG502-2-E units are delivered to customers with the following programmed settings:

Pump running time (tCO):	2,6 min
Idle time (tPA):	9 h
Code:	000 (programming protection)
System monitoring:	Pressure switch is activated (COP = PS)

These settings correspond to the mode of operation of the previous model IG433-5-51 and will have to be re-programmed, if necessary.

9.2 Replacing the previous model



Make sure that the voltage of the electrical system of the vehicle is in conformity with the voltage indicated on the control unit IG502-2-E. Versions for 12V DC or 24V DC are available.

- Read the article number (IG....) printed on the old unit to be replaced in order to determine to which mode of operation the new unit,
- Note down the values for the pause time (Pause) and, if necessary, the contact time which have been set on the old unit.
- Remove the old control unit and replace it by the IG502-2-E. The installation dimensions and the electrical connectors are identical!
- Set the mode of operation and setting values. For setting, proceed in the way described in the abbreviated instructions (pages 23 to 31) or in section 6 – “Programming”



The IG502-2-E is programmed via the control panel of the unit. Programming is possible only when the IG502-2-E is connected to the electrical system of the vehicle.

9.3 Replacement of other control units

In the annexed table (page 37), you find a list of further previous models which will have to be replaced by the IG502-2-E, if necessary. For the values to be programmed, please refer to this table.

For programming, observe the instructions given in the sections 6 – “Programming” and 7 – “Modes of operation”

9.4 Replacing IG471-21

9.4.1 Abbreviated programming instructions

- For changing over the programming of the IG502-2-E to the operating mode of the IG471-21, change the factory settings as follows:

Table 13. Replacing IG471-21























Step	Key	Action	Display	
1		Press for more than 2s		Display flashes (Code 000 factory setting)
2		Press briefly (to confirm code)		Pause time in timer mode LED "Pause" flashes
3		Press briefly		Pause time 9 h (Factory setting)
4	 			Set new value
5		Press briefly (to confirm new value)		Pump running time in timer mode LED "Contact" flashes
6		Press briefly		Pump running time 2,6 min (Factory setting)
7	 			Set new value

Table 13 continued

Step	Key	Action	Display	
8		Press briefly (to confirm new value)		Beginning of monitoring settings LEDs "PS" and "CS" flash
9		Press briefly		Monitoring via pressure switch (Factory setting)
10	 	Operate appropriate key until		Monitoring OFF is displayed
11		Press briefly		To confirm new settings
12		Press for more than 2s		New settings are saved to memory, display goes out.

9.5 Replacing IG472-11

9.5.1 Abbreviated programming instructions

- Terminal connection 30 is no longer used and must be removed on the connector.
- The minus input of the cycle switch must be changed over to plus.
- For changing the programming of the IG502-2-E to the operating mode of the IG472-11, change the factory settings as follows:

Table 14. Replacing IG472-11























Step	Key	Action	Display	
1		Press for more than 2s		Display flashes (Code 000 factory setting)
2		Press briefly (to confirm code)		Pause time in timer mode LED "Pause" flashes
3		Press briefly		Pause time 9 h (Factory setting)
4	 			Set new value
5		Press briefly (to confirm new value)		Pump running time in timer mode LED "Contact" flashes
6		Press briefly		Pump running time 2,6 min (Factory setting)
7	 			Set new value

Table 14 continued

Step	Key	Action	Display	
8		Press briefly (to confirm new value)		Beginning of monitoring settings LEDs "PS" and "CS" flash
9		Press briefly		Monitoring via pressure switch (Factory setting)
10	 	Operate appropriate key until		monitoring via cycle switch is set LED "CS" flashes
11		Press briefly		To confirm new setting
12		Press for more than 2s		New settings are saved to memory, display goes out.

9.6 Replacing IG434-1

9.6.1 Abbreviated programming instructions

- For changing over the programming of IG502-2-E to the operating mode of the IG434-1, the factory settings must be changed as follows:

Table 15. Replacing IG434-1























Step	Key	Action	Display	
1		Press for more than 2s		Display flashes (Code 000 factory setting)
2		Press briefly (to confirm code)		Pause time in timer mode LED "Pause" flashes
3		Press briefly		Pause time 9 h (Factory setting)
4	 			Set new value
5		Press briefly (to confirm new value)		Pump running time in timer mode LED "Contact" flashes
6		Press briefly		Pump running time 2,6 min (Factory setting)
7	 			Set new value

Table 15 continued

Step	Key	Action	Display	
8		Press briefly (to confirm new value)		Beginning of monitoring settings LEDs "PS" and "CS" flash
9		Press briefly		Monitoring via pressure switch (Factory setting)
10	 	Operate appropriate key until		Monitoring OFF is displayed
11		Press briefly		To confirm new settings
12		Press for more than 2s		New settings are saved to memory, display goes out.

9.7 Replacing IG472-22

9.7.1 Abbreviated programming instructions

- For changing over the programming of the IG502-2-E to the operating mode of the IG472-22, the factory settings must be changed as follows:

Table 16. Replacing IG472-22























Step	Key	Action	Display	
1		Press for more than 2s		Display flashes (Code 000 factory setting)
2		Press briefly (to confirm code)		Pause time in timer mode LED "Pause" flashes
3		Press briefly		Pause time 9 h (Factory setting)
4	 			Set new value
5		Press briefly (to confirm new value)		Pump running time in timer mode LED "Contact" flashes
6		Press briefly		Pump running time 2,6 min (factory setting)
7	 			Set new value

Table 16 continued











Step	Key	Action	Display	
8		Press briefly (to confirm new value)		Beginning of monitoring settings LEDs "PS" and "CS" flash
9		Press briefly (to confirm change of monitoring setting)		Monitoring via pressure switch (factory setting)
10	 	Operate appropriate key until		LED "CS" flashes, monitoring via cycle switch is set
11		Press briefly		To confirm new setting
12		Press for more than 2s		New settings are saved to memory, display goes out.

9.8 Replacing IG433-5-51

9.8.1 Abbreviated programming instructions

- For changing over the programming of the IG502-2-E to the operating mode of the IG433-5-51, the factory settings must be changed as follows:
- The pump running time (tCO) and system monitoring via the pressure switch remain unchanged.
- In a number of systems, however, the preset pause time (tPA = 9 h) has to be changed.
- See setting on old unit!



Table 17. Replacing IG433-5-51

Step	Key	Action	Display	
1		Press for more than 2s		Display flashes (Code 000 factory setting)
2		Press briefly (to confirm code)		Pause time in timer mode LED "Pause" flashes
3		Press briefly		Pause time 9 h (factory setting)
4	 			Set new value
5		Press briefly (to confirm new value)		To confirm new value
6		Press for more than 2s		New value is written to memory Display goes out.

10 Faults

All fault messages are displayed via the light-emitting diode  as centralized alarm. When a fault message is output, the control unit stops the normal sequence of operations, and the fault which has occurred is stored and displayed. The cause of the fault can be seen from the LED seven-segment display. This considerably facilitates fault diagnosis, necessitates monitoring of the system, however.

10.1 Display faults

Start the display mode with one of the two keys  . Faults are displayed: (Table 18):

10.2 Clear fault message

All fault messages can be acknowledged and cleared with this key . In the timer mode, this can also be performed with a connected external pushbutton.



Determine and rectify cause of fault before clearing the fault message. The user himself is liable for any damage resulting from operating the vehicle without lubrication.

The time for which the control unit and pump unit are operated without lubrication is indelibly stored as fault hours FH in the EEPROM.

Table 18. Display faults

Display	Meaning
FPS	Pressure switch fault: No signal is received from pressure switch during pump running time.
FCS	Cycle switch fault: No signal is received from cycle switch during pump running time.
FLl	Fault Low Level: The level in the reservoir has dropped below the minimum limit. The sequence of operations is stopped.

10.3 Block operation

! When no signal from the cycle switch is received, the control unit responds by activating the block mode of operation.

! If the preset PAUSE time t_{PA} is shorter than 15 min, the block pause b_{Lo} corresponds to this value.

10.4 Delayed signal from cycle switch

see Table 19.

Table 19. Delayed signal from cycle switch

Event	Device	Display on control panel
No signal from cycle switch during pump running time → normal operation is aborted 15 min block interval begins with inquiry of cycle switch		
Signal from cycle switch during 1st block interval → block operation is aborted Pause interval is continued up to the end of the regular preset pause time		
Signal from cycle switch during 2nd pump running time → block operation is aborted Regular preset pause time begins		
Signal from cycle switch during 2nd block interval → block operation is aborted Pause interval is continued up to end of regular preset pause time		
If a signal is received from the cycle switch during the 3rd pump running time → block operation is aborted Regular preset pause time begins		

10.5 No signal from cycle switch

Three pump running times and two block intervals without signal from cycle switch→

Block operation is aborted, a fault message is displayed!

Display on control panel:



Table 20. No signal from cycle switch

Device	Display on control panel
	



Determine and rectify cause of fault

10.6 No signal from pressure switch



If no signal is received from the pressure switch during the pump running time tCO or cCO, the normal sequence of operations is discontinued at the end of the pump running time, and a fault message is displayed!

Display on control panel:



10.7 Storage of fault times

10.7.1 Stoppage counter

The time which has elapsed since the occurrence of the fault message up to its acknowledgement is added up in hours. After acknowledgement, this value is automatically transferred to the fault hour counter.

10.7.2 Fault hour counter

In the fault hour counter, all stoppage times caused by faults during operation are added up. After calling parameter Fh, you can read the current counter reading in the display mode in two blocks of three digits each (see section 1, steps 12 - 14). The counter can count and indicate a maximum of 99999.9 hours. The smallest storable interval is 0.1 hour = 6 minutes.

The memory cannot be cleared.

11 Maintenance and repair

Carry out the following maintenance and inspection works at regular intervals:

- Check the level in the lubricant reservoir.
- Check all components of the system for leakage at regular intervals.
- Perform a visual check of the lubricating condition of bearings.
- You can check the basic function of the control unit and system components by activating an intermediate lubrication cycle.
- In addition, check electrical connections in the case of fault messages.
- Replace defective fuses exclusively by equivalent new ones.



Any other works the scope of which exceeds the above scope may be performed only by approved SKF service personnel.

12 Technical data

Table 21. Technical data

Data	Value
Rated voltage U_N	DC: 12 V or 24 V
Type of protection	IP 20, DIN 40050 / connector IP 00
Max. load output M	5 A at 24 V, 5 A at 12 V
SL output	4 W
Data preservation	unlimited
Working temperature	-25 °C to +75 °C
Storage temperature	-40 °C to +75 °C
EC directives	89 / 336 / EC und 95 / 54 / EC
Fusing max.	5 A
Dimensions L x W x H	138 x 65 x 40
Programmable pause times	0,1 h to 99,9 h
Programmable pump running times	0,1 min to 99,9 min
Programmable impulses	1 to 999
Operation hour memory	0 to 99999,9 h
Fault hour memory	0 to 99999,9 h

13 Service

If you have technical queries, please contact one of the following plants:

SKF Lubrication Systems Germany GmbH

Plant Berlin
Motzener Straße 35/37
12277 Berlin
Germany
Tel. +49 (0)30 72002-0
Fax +49 (0)30 72002-111

Plant Hockenheim
2. Industriestraße 4
68766 Hockenheim
Germany
Tel. +49 (0)62 05 27-0
Fax +49 (0)62 05 27-101

lubrication-germany@skf.com
www.skf.com/schmierung

14 Annex: Table

Table 22. Previous models to be replaced; Programming data for IG502-2-E

Control unit to be replaced	Centralized lubrication system type				To be programmed on IG502							
	Fluid grease with KFU...		Grease with KFG...		Pause time		Pump running time		Monitoring			Page
	With pressure switch	Without pressure switch	With cycle switch	Without cycle switch	Pause	Value	Contact	Value	PS	CS	OFF	
IG433-5-51	•				tPA	*)h	tCO	2,6 min	•			31
IG433-5-51/S2		•			tPA	*)h	tCO	2,6 min			•	13
IG433-5-51/S6		•			tPA	*)h	tCO	18 min			•	13
IG433-5-51/S7	•				tPA	*)h	tCO	2,6 min	•			13, 15
IG472-11			•**		tPA	*)h	tCO	***		•		25
IG472-22			•		tPA	*)h	tCO	***		•		29
IG472-22/S1			•		tPA	*)h	tCO	***		•		13, 15
IG472-33			•		cPA	*)Imp.	tCO	***		•		13, 15
IG472-33/S1			•		cPA	*)Imp.	tCO	***		•		13, 15
IG471-21				•**	tPA	*)h	tCO	*) min			•	23
IG471-21/S1				•**	tPA	*)h	tCO	*) min			•	13
IG471-21/S2				•**	tPA	*)h	tCO	*) min			•	13
IG434-1				•	tPA	*)h	tCO	*) min			•	27
IG434-3				•	cPA	*)Imp.	tCO	*) min			•	13
IG434-5	•				tPA	*)h	tCO	3 min	•			13, 15
IG434-6	•				cPA	*)Imp.	tCO	3 min	•			13, 15
IG434-8		•			tPA	*)h	tCO	*)min		•		13, 15

When replacing a control unit with negative cycle switch input such as IG434-2, IG434-4 or IG472-11, connect the minus terminal of the cycle switch to plus.

*) Take over system-specific settings of the unit to be replaced.

** Connection 30 no longer used! Must be removed from connector.

*** Time required for a lubrication cycle must be determined and set as pump running time value.



EU-Konformitätserklärung gemäß Richtlinie 2014/30/EU, Anhang IV über die elektromagnetische Verträglichkeit von Geräten

EC Declaration of Conformity following directive 2014/30/EC, annex IV about electromagnetic compatibility of devices

Der Hersteller SKF Lubrication Systems Germany GmbH, Werk Berlin, Motzener Straße 35/37, DE – 12277 Berlin erklärt hiermit die Übereinstimmung des Gerätes.
The manufacturer, SKF Lubrication Systems Germany GmbH, Berlin Facilities Motzener Straße 35/37, DE – 12277 Berlin, hereby declares the conformity of the device

Bezeichnung: Steuergerät
Designation: Control Unit
Typ: Baureihe IG502-2-E product line IG502-2-E
Sachnummer: IG502-2-E-E+912, IG502-2-E+924
Part number: IG502-2-E+912, IG502-2-E+924
Baujahr: siehe Typenschild
Year of construction: See type identification plate

mit allen einschlägigen Bestimmungen der nachfolgend genannten Richtlinien zum Zeitpunkt der Inverkehrbringung. Folgende Richtlinien und (harmonisierte) Normen in den jeweils zutreffenden Bereichen wurden angewandt:
complies with all relevant regulations of the following directives at the time when first being launched in the market. In addition, the following directives and (harmonized) standards were applied to the relevant areas:

- 2014/30/EU EMV EMC Richtlinie über die elektromagnetische Verträglichkeit | Industrie
Directive relating to electromagnetic compatibility | industry
- 2004/104/EG EMV KFZ EMC vehicles Richtlinie über die elektromagnetische Verträglichkeit von Kraftfahrzeugen
Directive relating to electromagnetic compatibility of vehicles
- 2011/65/EU RoHS II Richtlinie zur Beschränkung der Verwendung bestimmter gefährlicher Stoffe in Elektro- und Elektronikgeräten
Directive on the restriction of the use of certain hazardous substances in electrical and electronic equipment

Norm Standard	Edition Norm		Edition Norm		Edition Norm	
	Edition	Standard	Edition	Standard	Edition	Standard
DIN EN 61000-6-2	2006	DIN EN 50581	2013			
Berichtigung 1	2011					
DIN EN 61000-6-3	2011					
Berichtigung 1	2012					

951-200-046

SKF Lubrication Systems Germany GmbH

Hauptniederlassung, Standort Kassel
Heinrich-Hertz-Straße 2-8
69190 Waldkahl
Tel. +49 (0)642 27 33-0
Fax +49 (0)642 27 33-259

Standort Berlin
Motzener Straße 35/37
12277 Berlin
Tel. +49 (0)30 72002-0
Fax +49 (0)30 72002-111

Standort Hockenheim
2. Industriestraße 4
68766 Hockenheim
Tel. +49 (0)6205 27-0
Fax +49 (0)6205 27-101

Gründungsleiter: Volker Pöschel | Sales Director: Schwabert | Registrator: Schwabert | HRB 48411 | Ust-IdNr.: DE441-721028

1 / 2

3. Aufl. 1. 01/2016



EU-Konformitätserklärung gemäß Richtlinie 2014/30/EU, Anhang IV über die elektromagnetische Verträglichkeit von Geräten

EC Declaration of Conformity following directive 2014/30/EC, annex IV about electromagnetic compatibility of devices

Hinweis zur CE-Kennzeichnung / Notes related to the CE marking

Die CE-Kennzeichnung erfolgt gemäß den Forderungen der angewandten Richtlinien:
CE marking is effected following the requirements of the applied directives:

- 2014/30/EU EMV EMC Richtlinie über die elektromagnetische Verträglichkeit | Industrie
Directive relating to electromagnetic compatibility | industry
- 2011/65/EU RoHS II Richtlinie zur Beschränkung der Verwendung bestimmter gefährlicher Stoffe in Elektro- und Elektronikgeräten
Directive on the restriction of the use of certain hazardous substances in electrical and electronic equipment

SKF Lubrication Systems Germany GmbH

Berlin, 17.11.2015

vertreten durch
represented by

I.V. 
Jürgen Kreuzkämper
Manager R&D Germany
SKF Lubrication Business Unit

i.A. 
Richard Lindemann
Manager Sustain Engineering Berlin
SKF Lubrication Business Unit

951-200-046

SKF Lubrication Systems Germany GmbH

Hauptniederlassung, Standort Kassel
Heinrich-Hertz-Straße 2-8
69190 Waldkahl
Tel. +49 (0)642 27 33-0
Fax +49 (0)642 27 33-259

Standort Berlin
Motzener Straße 35/37
12277 Berlin
Tel. +49 (0)30 72002-0
Fax +49 (0)30 72002-111

Standort Hockenheim
2. Industriestraße 4
68766 Hockenheim
Tel. +49 (0)6205 27-0
Fax +49 (0)6205 27-101

Gründungsleiter: Volker Pöschel | Sales Director: Schwabert | Registrator: Schwabert | HRB 48411 | Ust-IdNr.: DE441-721028

2 / 2

3. Aufl. 1. 01/2016

Order No. 951-180-002**SKF reserves the right to make content and technical changes!**

Last revision: 06.02.2017

This documentation and parts thereof may only be reprinted with the express permission of SKF Lubrication Systems Germany GmbH. The specifications given in this installation instructions are checked for accuracy with the greatest of care. However, we do not accept liability for any losses or damages of whatever kind that arise directly or indirectly from the use of the material contained herein.

Important product usage Information

All SKF Lubrication Systems Germany GmbH products may only be used as intended and as described in the installation instructions. If the installation instructions are delivered with your product, read them carefully and follow them.

Not all lubricants can be conveyed with centralized lubrication systems. If required, SKF Lubrication Systems Germany GmbH can check the lubricant selected by the user to make sure that it is suitable for conveyance in centralized lubrication systems. All lubrication systems and components that are manufactured by SKF Lubrication Systems Germany GmbH are not approved for use in conjunction with gases, liquefied gases, gases dissolved under pressure, vapours, and fluids with a vapour pressure of more than 0.5 bar above normal atmospheric pressure (1013 mbar) at the maximum permitted temperature.

Hazardous materials of any kind, especially the materials classified as hazardous by CLP Regulation EC 1272/2008 may only be used to fill SKF centralized lubrication systems and components and delivered and/or distributed with the same after consulting with and receiving written approval from SKF.

SKF Lubrication Systems Germany GmbH

Plant Berlin
Motzener Straße 35/37
12277 Berlin
Germany
Tel. +49 (0) 30 72002-0
Fax +49 (0) 30 72002-111

Plant Hockenheim
2. Industriestraße 4
68766 Hockenheim
Germany
Tel. +49 (0) 62 05 27-0
Fax +49 (0) 62 05 27-101

lubrication-germany@skf.com
www.skf.com/schmierung

® SKF is a registered trademark of the SKF Group.
© SKF Group 2017

