

R05-A

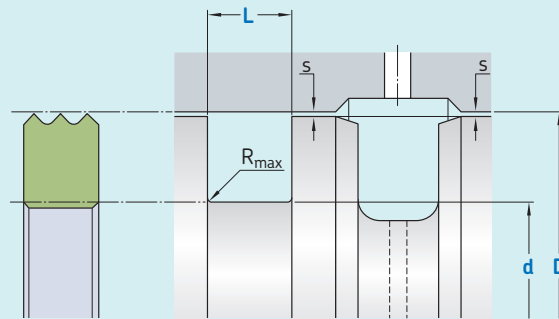

Ordering dimensions in **blue**

Surface roughness	R_{tmax}	R_a
	μm	
Sliding surface	$\leq 2,5$	$0,1-0,5$
Bottom of groove	$\leq 6,3$	$\leq 1,6$
Groove face	≤ 15	≤ 3

Hardness: Min 45 HRC (55 HRC recommended), hardened depth $> 0,3$ mm.
 Bearing area: 50–95% and a cutting depth of $0,5 R_z$ based on $C_{ref} = 0\%$

Standard dimensions

D^*		d	L	R_{max}	s
over	incl.	$h8$	$+0,2$		
mm					
13	30	$D - 8$	4,5	0,2	H9/e8
30	46	$D - 10$	5,6	0,2	H9/e8
46	68	$D - 12$	5,6	0,2	H9/e8
68	100	$D - 15$	7,7	0,2	H7/f7
100	160	$D - 20$	9,2	0,2	H7/f7
160	225	$D - 25$	11,3	0,2	H7/f7
225	330	$D - 30$	13,5	0,2	H7/f7
330		$D - 40$	18,5	0,2	H7/f7

* Tolerance area counter surface ≤ 68 mm \rightarrow H9, > 68 mm \rightarrow H7

Ordering example

Profile
 $d \times D \times L$ [mm]
 Sealing material

Rotary seal R05-A
100 x 120 x 9,2
 ECOPUR

Operating parameters

Material Seal	Temperature		Speed ¹⁾	Pressure ²⁾
	from	to	max	max
	°C		m/s	bar (MPa)
■ ECOPUR	-30	+110	0,2	160 (16)
■ H-ECOPUR	-20	+110	0,2	160 (16)
■ S-ECOPUR	-20	+110	0,2	160 (16)
■ T-ECOPUR	-50	+110	0,2	160 (16)
■ SKF Ecorubber-1	-30	+100	0,2	100 (10)
■ SKF Ecorubber-H	-25	+150	0,2	100 (10)
■ SKF Ecorubber-2	-20	+200	0,2	100 (10)
■ SKF Ecorubber-3	-50	+150	0,2	100 (10)
■ SKF Ecoflas	-10	+200	0,2	100 (10)

IMPORTANT NOTE: The stated operating conditions represent general indications. It is recommended not to use all maximum values simultaneously.

¹⁾ Surface speed limit values are valid only in the presence of a lubrication film.

²⁾ Pressure ratings depend on the size of the extrusion gap.