

# K02-PD

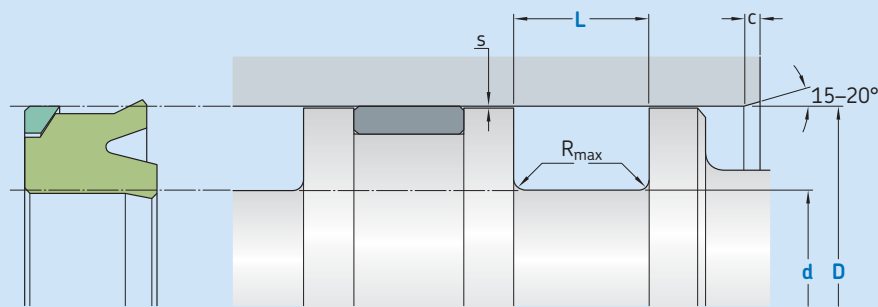

Ordering dimensions in **blue**

Surface roughness	$R_{tmax}$	$R_a$
<b>Sliding surface</b>	$\leq 2,5 \mu m$	$0,05-0,2 \mu m$
<b>Bottom of groove</b>	$\leq 6,3 \mu m$	$\leq 1,6 \mu m$
<b>Groove face</b>	$\leq 15 \mu m$	$\leq 3 \mu m$

Bearing area: 50–95% and a cutting depth of  $0,5 R_z$ , based on  $C_{ref} = 0\%$

Standard dimensions						Maximal radial extrusion gap			
D	d	L	$R_{max}$	c	$s^*$				
H9	h10	+ 0,2				20 bar	100 bar	400 bar	700 bar
over	incl.					mm			
mm						mm			
<b>13</b>	<b>25</b>	D - 8	6,0	0,4	3,5	0,80	0,80	0,30	0,04
<b>25</b>	<b>50</b>	D - 10	7,0	0,4	4,0	1,00	1,00	0,37	0,04
<b>50</b>	<b>75</b>	D - 12	8,0	0,4	4,5	1,25	1,24	0,42	0,05
<b>75</b>	<b>150</b>	D - 15	10,0	0,4	5,0	1,50	1,47	0,46	0,05
<b>150</b>	<b>300</b>	D - 20	12,0	0,4	6,0	2,00	1,77	0,54	0,06
<b>300</b>	<b>500</b>	D - 25	18,0	0,4	8,5	2,5	2,06	0,62	0,06
<b>500</b>	<b>750</b>	D - 30	20,0	0,4	10,0	3,00	2,43	0,76	0,06
<b>750</b>		D - 40	26,0	0,4	13,0	3,00	2,43	0,76	0,06

\* Extrusion gap values shown above are valid for a temperature of 70 °C, higher temperatures require lower values.

## Ordering example

Profile  
D x d x L [mm]  
Sealing material / Backup ring

Piston seal K02-PD  
**100 x 85 x 10**  
ECOPUR / SKF Ecotal

## Operating parameters

Material Seal	Back-up ring	Temperature		Speed <sup>1)</sup>	Pressure <sup>2)</sup>
		from	to	max	max
		°C		m/s	bar (MPa)
■ ECOPUR		-30			
■ ECOPUR LD		-35			
■ G-ECOPUR	■ SKF Ecotal <sup>3)</sup>	-30	+100	0,5	700 (70)
■ H-ECOPUR	■ SKF Ecomid <sup>3)</sup>	-20		0,7	
■ S-ECOPUR		-20		0,7	
■ T-ECOPUR		-40		0,5	

IMPORTANT NOTE: The stated operating conditions represent general indications. It is recommended not to use all maximum values simultaneously.

<sup>1)</sup> Surface speed limit values are valid only in the presence of a lubrication film.

<sup>2)</sup> Pressure ratings depend on the size of the extrusion gap.

<sup>3)</sup> D ≤ 260 mm → SKF Ecotal, D > 260 mm → SKF Ecomid.