

# K19-F

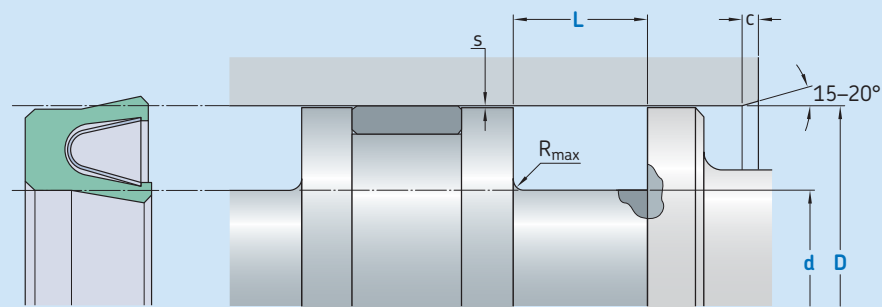

Ordering dimensions in **blue**

Surface roughness	$R_{tmax}$	$R_a$
<b>Sliding surface</b>	$\leq 2 \mu m$	$0,05-0,2 \mu m$
<b>Bottom of groove</b>	$\leq 6,3 \mu m$	$\leq 1,6 \mu m$
<b>Groove face</b>	$\leq 15 \mu m$	$\leq 3 \mu m$

Bearing area: 50–95% and a cutting depth of  $0,5 R_z$ , based on  $C_{ref} = 0\%$

Standard dimensions						Maximal radial extrusion gap				
D	d	L	$R_{max}$	c	$s^*$					
H9	h10	+ 0,2				20 bar	100 bar	200 bar	300 bar	400 bar
over	incl.									
mm						mm				
<b>10</b>	<b>18</b>	D – 4,5	3,6	0,3	1,13	0,25	0,12	0,10	0,08	0,07
<b>18</b>	<b>50</b>	D – 6,2	4,8	0,3	1,55	0,35	0,17	0,12	0,1	0,08
<b>50</b>	<b>120</b>	D – 9,4	7,1	0,3	2,35	0,45	0,22	0,17	0,12	0,1
<b>120</b>	<b>630</b>	D – 12,2	9,5	0,3	3,05	0,6	0,31	0,25	0,15	0,12
<b>630</b>	<b>1 600</b>	D – 19	15	0,3	4,75	0,87	0,48	0,38	0,28	0,2

\* Extrusion gap values shown above are valid for a temperature of 80 °C, higher temperatures require lower values.

## Ordering example

Profile  
D x d x L [mm]  
Sealing material / Spring

Piston seal K19-F  
100 x 90,6 x 7,1  
SKF Ecoflon 3 / 1.4310

## Operating parameters

Material Seal	Spring	Temperature		Speed <sup>1)</sup>	Pressure <sup>2)</sup>
		from	to	max	max
		°C		m/s	bar (MPa)
SKF Ecoflon 1					200 (20)
SKF Ecoflon 2	1.4310 <sup>3)</sup>	-200	+260	15	400 (40)
SKF Ecoflon 3	2.4711 <sup>4)</sup>				
SKF Ecoflon 4					
SKF Ecowear 1000			+90		200 (20)

IMPORTANT NOTE: The stated operating conditions represent general indications. It is recommended not to use all maximum values simultaneously.

<sup>1)</sup> Surface speed limit values are valid only in the presence of a lubrication film.

<sup>2)</sup> Pressure ratings depend on the size of the extrusion gap.

<sup>3)</sup> Available for standard and x00 spring versions.

<sup>4)</sup> Available for x00 spring versions.