

# SKF sensor technology

– detects the real situation

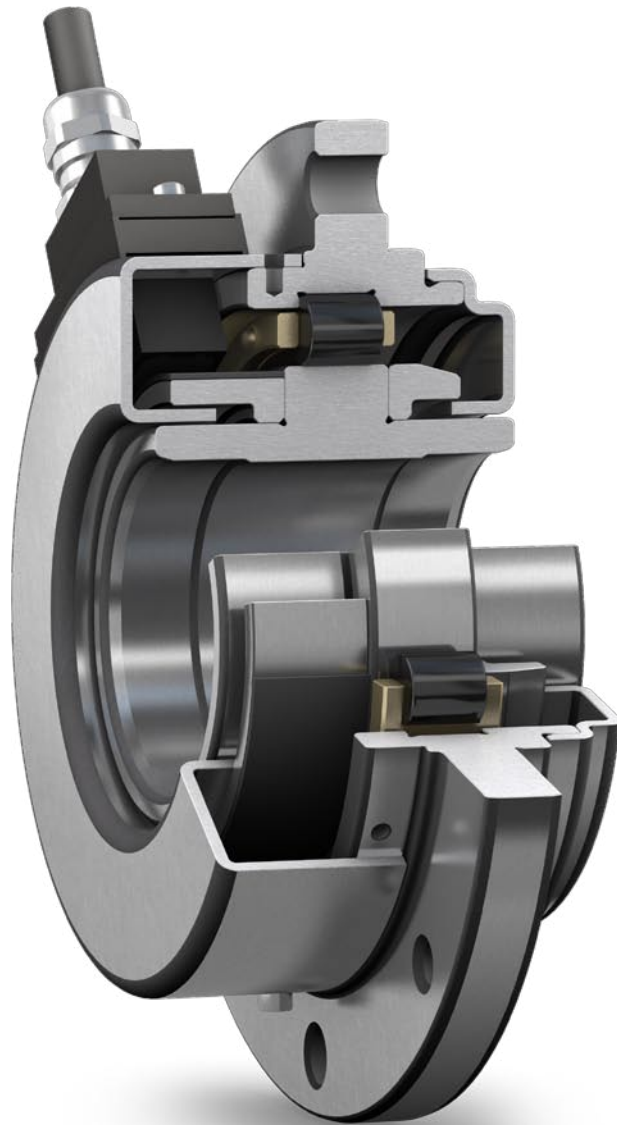

# Operating principle

SKF sensor technology can be combined with various bearing types either as a special design for integrated solutions or in combination with standard dimension bearings.

The sensor unit includes a code ring, which is linked with the rotating inner ring of the bearing. This code ring is magnetized with a sequence of north and south magnetic poles. Magnetic field sensors inside the sensor body detect the change in magnetic field and convert this to digital signals.

Each rotation of the shaft produces a pre-defined number of pulses. The sensor also provides rotational speed and incremental or absolute position output.

The speed sensor has 2 outputs: A and B. Due to the phase shift between the A and B outputs, the direction of rotation can be defined as well (→ **fig. 1**). The absolute position sensor has a serial data output that provides the angle in a binary format (Other output available on request).



# Applications

SKF integrated sensors provide speed and incremental or absolute position information. Due to the integration of the sensor into the bearing, it is a very robust solution. Both the electronics and mechanics are well protected from the harsh environment. It is remarkable that the SKF sensor solution is a plug & play solution, which is important for different markets, to reduce the costs of a standstill.

The main application will be industrial electrical motors, especially traction motors in the railway industry as well as in the oil & gas, off highway and automotive markets.

*The output from the speed sensor is two square pulse signals with a 90° phase difference, which allows you to determine the direction of rotation.*

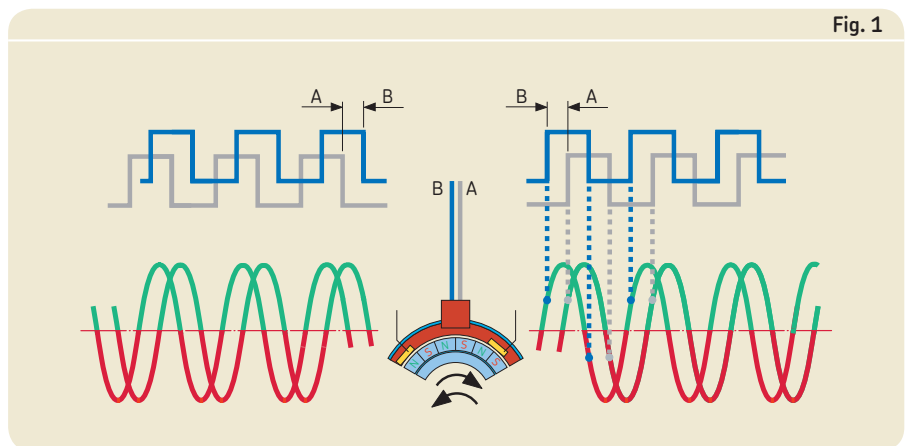

Fig. 1

	High resolution speed sensor (HIS)	Speed (IIS) and high resolution absolute position sensor (HAPS)	Speed (IIS) and position sensor (PS)
<b>Reference position</b>	Optional		
<b>Absolute position</b>		X	
<b>Speed</b>	X	X	X
<b>Market</b>	Railway, off highway, oil & gas	Railway, off highway, oil & gas	Automotive, off highway

# Speed and incremental position for small size bearings

## SKF motor encoder units, BMB, BMO and BMH series

### Integrated units from SKF for medium power density AC motors: BMB and BMO series

SKF motor encoders (BMB and BMO series) are compact mechatronic units integrated into bearings that combine sensor and bearing technology. Available for shaft diameters ranging from 15 to 45 mm, these encoder units are mounted directly inside the motor and require only 6 mm of extra space in the axial direction. The sensor body, impulse ring and bearing are mechanically attached to each other, forming a compact, integrated, ready-to-mount unit that is shielded from external influences. SKF motor encoder units, which can be installed on either side of asynchronous motors, provide a signal resolution between 32 and 80 digital pulses per revolution. They can accurately detect speeds from 0 to 14 000 r/min, depending on the speed limits of the bearing. The SKF motor encoder unit uses a compact and robust active sensor that produces an incremental encoder signal. The sensor is accurate down to zero r/min. Its main components include an impulse ring, a sensor body with sensors and a connecting cable.

A composite, magnetized impulse ring is attached to the bearing inner ring. Depending on the bearing size, it is divided into a number of north and south poles.

The sensor body has one double cell, enabling the direction of rotation to be determined. A small integrated circuit contains not only the Hall cells as active elements but also the electronics for signal amplification and conversion. The leading signal determines the direction of rotation.

### Encoder units for extreme operating conditions: BMH range

SKF also has a series of high performance motor encoder units designed for extreme operating conditions. In applications with extreme conditions of temperature and motor power, the magnetic technology may reach its limits. For those extreme operating conditions, SKF has developed a high performance inductive technology, based on sensing of inductance variations.

Mechanical data				
	Min.	Typ.	Max.	Unit
Cable lengths	–	Customized	–	m
Cable outlet		Radial		
Connector		Open end as standard, customization possible		

Electrical data				
	Min.	Typ.	Max.	Unit
Supply voltage (BMB, BMO)	4,5	–	24	V
Supply voltage (BMH)	5	–	24	V
Output type	Quadrature (A and B), open collector type			
Operating temperature	–40		+120	°C
Pulses per revolution	32	<sup>1)</sup>	80	pulses
Period accuracy	–4	0	+4	%
Duty cycle (BMB, BMO)	40	50	60	%
Duty cycle (BMH)	35	50	65	%
Phase shift between A and B (BMO)	70	90	110	°
Phase shift between A and B (BMB, BMH)	60	90	120	°
Permissible rotational speed	0		7 500 <sup>2)</sup>	r/min

<sup>1)</sup> Depending on bearing diameter, 6202 (bore 15 mm) up to 6209 (bore 45 mm) available.  
<sup>2)</sup> Valid for 6206 bearing type (30 mm bore).

Environmental data			
	Standard	Level	Performance
Electrostatic discharge (BMB, BMO)	IEC 61000-4-2	Contact 4 kV Air 8 kV	B B
Electrostatic discharge (BMH)	IEC 61000-4-2	Contact 8 kV Air 15 kV	B B
Radiated immunity (BMB, BMO)	IEC 61000-4-3	10 V/m	A
Radiated immunity (BMH)	IEC 61000-4-3	30 V/m	A
Magnetic field	IEC 61000-4-8	30 A/m	A
Electric fast transient	IEC 61000-4-4	4 000 V	B

The sensor then consists of coils sensing the presence of a specially designed induction tooth ring. This new technology makes the SKF encoder unit immune to virtually all electro-magnetic disturbances.

SKF motor encoder units, BMB, BMO and BMH series, offer a number of benefits for many applications which have a need for increased compactness and robustness such as traction and pump AC motors for forklifts, golf carts, light electric vehicles, etc.



# Speed for medium size bearings

SKF sensor bearings and units are comprised of bearing functions and sensor electronics.

The integrated incremental sensor is capable of detecting shaft speed and direction of rotation with high resolution and accuracy. The number of output pulses is up to 64 (HHS) times the number of code ring poles (the number of poles depends on bearing diameter, e.g. 122 for 6213).

Additionally, an option reference position as well as temperature or redundancy of the speed and direction sensor are possible. It is a non-contact sensing principle that helps to ensure a long operational life. The SKF integrated incremental sensor is highly resistant to electromagnetic disturbances and thus generates reliable output.

Integration with rolling bearings starting with a bore size of 65 mm offers a number of benefits for many industrial applications such as traction motors, electrical motors, and gears.



## Mechanical data

	Min.	Typ.	Max.	Unit
<b>Cable lengths</b>	–	Customized	–	m
<b>Mounting position</b>		Radial <sup>1)</sup>		
<b>Connector</b>		Open end as standard, customization possible		

<sup>1)</sup> axial on request

## Electrical data

	Min.	Typ.	Max.	Unit
<b>Supply voltage</b>	4,75	12	30	V
<b>Supply current</b>	15	28	40	mA
<b>Push-pull output<sup>1)</sup></b> (load = 20 mA)	0		0,8	V
	$V_b - 2,5 V$		$V_b$	V
<b>Sensor accuracy over speed and temperature range</b>	-0,1		+0,1	°
<b>Sensor resolution</b>	122	<sup>2)</sup>	7 808 <sup>3)</sup>	ppr
<b>Permissible rotational speed</b>	0		10 000	r/min
<b>Measuring range</b>	0		360	°

<sup>1)</sup> Output like RS485 also available

<sup>2)</sup> Depends on bearing size

<sup>3)</sup> Valid for bearing size with a bore of 65 mm. Bigger sizes allow higher resolution.

## Environmental data

	Min.	Typ.	Max.	Unit
<b>Operating temperature</b>	-40	20	+125	°C
<b>CE/EMC</b>	According to EMC directive 2004/108/EC, harmonized standard EN 50121-3-2 (2006) Railway			
<b>Protection class</b>	IP 67			
<b>Shock and vibration</b>	According to EN 61373 class 2			

# Speed and absolute position for medium size bearings

SKF sensor bearings and units are comprised of bearing functions and sensor electronics. The integrated absolute position sensor (HAPS) is capable of detecting shaft position with high resolution and accuracy.

The sensor is optimized for motor encoding applications and provides the absolute rotor position within a rotor pole.

This sensor unit can be customized for an optimal fit to meet the customer needs.

Options are temperature sensor, speed sensor (IIS) or redundancy of the position, speed and direction sensor. As it is a non-contact sensing design, it helps to ensure a long operational life. The SKF integrated incremental sensor is highly resistant to electromagnetic disturbances and generates reliable output. Integration with rolling bearings offers a number of benefits for many industrial applications such as traction motors, electrical motors, gears, etc.



## Mechanical data

	Min.	Typ.	Max.	Unit
<b>Cable lengths</b>	–	Customized	–	m
<b>Mounting position</b>		Axial		
<b>Connector</b>		Open end		

## Electrical data

	Min.	Typ.	Max.	Unit
<b>Supply voltage (HAPS, IIS)<sup>1)</sup></b>	10	12	30	V
<b>Supply current (HAPS)</b>	40	140	200	mA
<b>Supply current (IIS)</b>	15	50	100	mA
<b>Output<sup>2)</sup></b>	RS485 compatible output			
<b>Sensor accuracy (HAPS)</b>	–0,075		+0,075	%
<b>Sensor accuracy (IIS)</b>	–1		+1	%
<b>Sensor resolution (HAPS)</b>		5632 <sup>3)</sup>		ppr
<b>Sensor resolution (IIS)</b>		440 <sup>3)</sup>		ppr
<b>Permissible rotational speed</b>	0		750 <sup>4)</sup>	r/min
<b>Measuring range</b>	0		360	°

<sup>1)</sup> HAPS = High resolution absolute position sensor, IIS = Integrated incremental sensor  
<sup>2)</sup> HAPS angle is provided by a dataframe, other outputs on request.  
<sup>3)</sup> Full rotation sensor resolution optimised for application.  
<sup>4)</sup> Higher speeds not tested yet.

## Environmental data

	Min.	Typ.	Max.	Unit
<b>Operating temperature</b>	–30	20	+105	°C
<b>CE/EMC</b>	According to EMC directive 2004/108/EC, the sensor meets the harmonized standard EN 50121-3-2 (2006) Railway			
<b>Protection class</b>	IP 67			
<b>Shock and vibration</b>	According to EN 61373 class 2			



Beside the previously described sensor technologies, which are mainly developed for traction motors, SKF also offers axlebox bearing units with integrated speed and/or temperature sensors for

- tapered bearing units
- compact taper bearing units
- cylindrical roller units

For further information, contact your nearest SKF office.

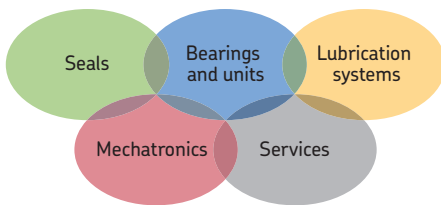

#### The Power of Knowledge Engineering

Drawing on five areas of competence and application-specific expertise amassed over more than 100 years, SKF brings innovative solutions to OEMs and production facilities in every major industry worldwide. These five competence areas include bearings and units, seals, lubrication systems, mechatronics (combining mechanics and electronics into intelligent systems), and a wide range of services, from 3-D computer modelling to advanced condition monitoring and reliability and asset management systems. A global presence provides SKF customers uniform quality standards and worldwide product availability.

© SKF is a registered trademark of the SKF Group.

© SKF Group 2010

The contents of this publication are the copyright of the publisher and may not be reproduced (even extracts) unless prior written permission is granted. Every care has been taken to ensure the accuracy of the information contained in this publication but no liability can be accepted for any loss or damage whether direct, indirect or consequential arising out of the use of the information contained herein.

PUB MT/P2 11042 EN · September 2010

Printed in Sweden on environmentally friendly paper.

