

Multi-outlet drum pump GSE

Version	03
Date of issue	June 2016
Publication number	951-130-407
Languages	EN
Country/Countries	...



Multi-outlet drum pump GSE

English translation of the original installation
and commissioning manual

Imprint

This manual – containing installation, operation and maintenance instructions complies with EC-Machinery Directive 2006/42/EC and is an integral part of the described lubrication system. It must be kept for future use.

This manual – containing installation, operation and maintenance instructions was created in accordance with the valid standards and regulations on documentation.

© SKF

This documentation is protected by copyright. All rights reserved. The photomechanical reproduction, copying, and distribution of this documentation or parts thereof by means of processes such as data processing, data carriers, and data networks is strictly prohibited without the express permission of SKF.

Subject to editorial or technical modifications.

Service

For all technical questions, please contact:

SKF France
Lubrication Product Division
204, bld Charles de Gaulle
B.P. 239
37540 St-Cyr-sur-Loire
FRANCE
Tel. +33 (0) 247 40 087

Or an SKF Service Centre, the addresses of which are given on our website:

lubrication-france@skf.com
www.skf.com

Contents

Multi-outlet drum pump GSE	3	2.4 Lubricants and the environment	14	7. Shutdown	29
Imprint	4	2.5 Danger relating to lubricants .	14	7.1 Temporary shutdown	29
Service	4	3. Design and function	15	7.2 Permanent shutdown	29
Information concerning the EC Declaration of Conformity and the EC Declaration of Incorporation	6	3.1 Versions	15	8. Maintenance	30
General	8	3.2 Construction	17	9. Failures	31
Meaning of symbols and corresponding information	8	3.3 Function.	19	Technical data	33
1. Safety instructions	9	4. Installation instructions	20	11. Spare parts and accessories	35
1.1 Intended use	9	4.1 Positioning.	20		
1.2 Authorized personnel	10	4.2.2 Installation	21		
1.3 Danger relating to electric current	10	4.3 Pump element.	22		
1.4 Danger relating to system pressure	10	Pump element assembly.	23		
1.5 Warranty	11	4.5 Level monitoring.	24		
2. Lubricants	12	5. Transport, delivery and storage . 25			
2.1 General	12	5.1 Transport.	25		
2.2 Selection of lubricants	13	5.2 Delivery	25		
2.3 Approved lubricants	13	5.3 Storage	25		
		6. Activation	26		
		6.1 General	26		
		6.2. Commissioning.	26		
		6.3 Flow rate adjustment	27		
		6.5 Replacing the drum.	28		

Information concerning the EC Declaration of Conformity and the EC Declaration of Incorporation

For the product(s) designated below:

Drum pump

Product line:

GSE

SKF herewith certifies that it conforms to the pertinent safety requirements set forth in the following Council Directive(s) for the harmonization of the laws of the Member States...

- Machinery Directive 2006/42/EC

Note:

- 1 This declaration certifies conformity with the aforementioned directive(s), but does not contain any assurance of properties.
- 2 The safety instructions in the owner's manual must be observed.

3 The certified product must not be started up until it is confirmed that the equipment, machinery, vehicle or the like in which the product was installed meets the provisions and requirements of the national directives to be applied.

4 Operation of the products on non-standard main voltage as well as nonobservance of installation instructions can affect the EMC properties and electrical safety.

SKF further declares that the above mentioned product:

- is meant for integration into a machinery / for connection to other machinery according to the EC-Machinery Directive 2006/42/EC, Appendix II Part B. Starting up the product is not permissible until it is assured that the machinery, vehicle or the like in which the product was installed meets the provisions and requirements of the regulations set forth in the EC Directive 2006/42/EC.

- with reference to the EC Directive 97/23/EC concerning apparatus subjected to pressure, this product must only be used as intended and according to the Owner's manual. Especially observe the following:
 - Products of SKF must not be used in conjunction with fluids, group I (hazardous fluids), according to the definition of article 2 paragraph 2 of the Directive 67/548/EC dtd. 27th June, 1967; and are not approved for application with such fluids.
 - None of the products manufactured by SKF can be used in conjunction with gases, liquefied gases, pressurized gases in solution and fluids with a vapor pressure exceeding normal atmospheric pressure (1013 mbar) by more than 0,5 bar at their maximum permissible temperature.

- When used as intended, the products supplied by SKF do not reach the limit values listed in the Article 3 par. 1, sections 1.1 to 1.3 and par. 2 of the Directive 97/23/EC. Therefore, they do not come under the requirements set forth in annex I of that Directive. They are not labeled with the CE mark with reference to the Directive 97/23/EC. They are classified by SKF to come under Article 3 par. 3 of the Directive.
- The EC Declaration of Conformity and EC-Declaration of Incorporation is part of the product documentation.

General

Meaning of symbols and corresponding information

In this manual, the symbols and safety wordings shown on this page are intended to communicate a particular risk to persons, material assets, or the environment.

All safety instructions must be respected by person exposed to these risks. The safety instructions must be communicated to all other persons.

Instructions attached directly to the equipment, such as







- rotational direction arrows
- fluid connection labels, etc.

must be respected and remain perfectly legible.

It is essential to read these instructions thoroughly and to respect the safety instructions given.

Table 1

Hazard symbols

Symbol	Standard	Meaning
	DIN 4844-2 W000	General hazard
	DIN 4844-2 W008	Voltage
	DIN 4844-2 W026	Hot surface
	DIN 4844-2 W028	Slippery floor
	DIN 4844-2 W027	Risk of hand injury
	DIN 4844-2 W55	Risk of pollution

1. Safety instructions

The described product was manufactured in accordance with all generally acknowledged regulations pertaining to technology, occupational safety, and accident prevention. However, dangers that can cause physical injury to persons or damage to other material assets might still occur during the use of the product.



These instructions must be read and understood by all persons who are involved with the installation, operation, maintenance, and repair of the product. These instructions must be kept close to the equipment for future reference.

Note that these installation instructions is an integral part of the product. It must be handed over to the new operator of the product if the product is sold.



In addition to the information provided in the installation instructions, all generally applicable regulations on accident prevention and the environment must be observed.

1.1 Intended use

The described product is for supplying centralized lubrication systems with lubricant and is intended for use in centralized lubrication systems. Other use or use beyond this purpose is considered unintended.

Products of SKF must not be used in conjunction with substances and mixtures classified as hazardous by the Annex I part 2-5 of the CLP regulation (EC 1272/2008), and identified with hazard pictograms GHS01 - GHS06 and GHS08.

None of the products manufactured by SKF can be used in conjunction with gases, liquefied gases, pressurized gases in solution and fluids with a vapor pressure exceeding normal atmospheric pressure (1013 mbar)

by more than 0.5 bar at their maximum permissible temperature.

Unless otherwise noted, products of SKF must not be used in conjunction with explosive atmospheres according to the ATEX-Directive 2014/34/EU.



All products from SKF may be used only for their intended purpose as described in this brochure and in any instructions.

1.2 Authorized personnel

The products described in the installation instructions may only be installed, operated, maintained, and repaired by qualified experts. Qualified experts are persons who have been trained, instructed, and familiarized with the end product into which the described product is installed.

These persons are considered capable of such tasks due to their education, training, and experience with valid standards, conditions, accident prevention regulations in effect, and installation conditions. They should be able to carry out the required tasks and to recognize – and thus avoid – any dangers that might otherwise occur.

A definition of what constitutes a qualified person and who are unqualified persons are stipulated in DIN VDE 0105 and IEC 364.

1.3 Danger relating to electric current

The electrical connection for the described product may only be established by qualified, instructed persons who have been authorized by the operator or owner to carry out this task. If the product is improperly connected, substantial material or personal damage may be the consequence.



DANGER!

Working on products that have not been disconnected from the power supply can cause serious injury or death to persons. Installation, maintenance, and repair work may only be carried out by qualified experts on products that have been disconnected from the power supply. The supply voltage must be turned off before any product components are opened. .

1.4 Danger relating to system pressure



DANGER!

Centralized lubrication systems are under pressure when they are being operated. Such systems must therefore be depressurized before starting installation, maintenance, or repair work and before making any changes to the system.

1.5 Warranty

The instructions do not contain any information on the warranty. This can be found in the General Conditions of Sales, which are available at: www.skf.com/lubrication.

2. Lubricants

2.1 General



All SKF products must only be used for their intended purpose and in accordance with the specifications of the installation instructions for the product in question.

The intended use of this product is for the centralized lubrication/lubrication of bearings and wear points with lubricants. All physical limitations of use stipulated in the documentation of the product such as the owner's manual, technical drawings and catalogs must be observed.

More specifically, we call your attention to the fact that substances and mixtures classified as hazardous by the Annex I part 2-5 of the CLP regulation (EC 1272/2008), and identified with hazard pictograms GHS01-GHS06 and GHS08, can only be used to feed

the SKF centralized lubrication systems, transported or distributed by these systems after consultation with SKF and obtaining written permission.

All products manufactured by SKF are not approved for use in conjunction with gases, liquefied gases, pressurized gases in solution and fluids with a vapor pressure exceeding normal atmospheric pressure (1013 mbars) by more than 0,5 bar at their maximum permissible temperature.

Should there be a need to use the product to convey media other than lubricants or hazardous substances, this must be discussed with SKF first and the company must give express written permission.

In the opinion of SKF, lubricants constitute a design element that must be considered when selecting components and designing centralized lubrication systems. The lubrication properties of the lubricants in question must be considered.

2.2 Selection of lubricants



You must observe the machinery manufacturer's information on the lubricants to be used in the machinery.



DANGER!

The manufacturer of the bearing or machinery to be lubricated will specify the lubricant requirements for each point to be lubricated. You must make sure that the required quantity of lubricant is provided to the relevant lubricating point. If a lubricating point is insufficiently lubricated, the bearing may become damaged or jammed.

While the machinery/bearing manufacturer usually specifies lubricants, it is the owner/operator (or maintenance person) who must finally select the appropriate lubricant, with the help of the lubricant supplier. When selecting a lubricant, the type of bearing/wear point, the stresses and strains to be expected during operation, and anticipated ambient conditions must be taken into account. All financial/economic aspects must also be considered.



If required, SKF can help customers to select suitable components for the conveyance of the selected lubricant and to plan and design their centralized lubrication system.

If you have further questions, you can contact SKF.

We can test lubricants in our own laboratory to establish their suitability for conveyance (e.g. 'oil separation' behavior) in centralized lubrication systems.

You can request an overview of lubricant tests offered by SKF from our Service Center.

2.3 Approved lubricants



DANGER!

Only lubricants that have been approved by SKF for use with the product may be used. Unsuitable lubricants can cause product malfunctions and damage to property.

**DANGER!**

Different lubricants must not be mixed together. Doing so can cause damage and require extensive cleaning of the products/centralized lubrication system. To prevent confusion, we recommend that you attach information indicating the lubricant to be used on the lubricant reservoir.

The described product can be operated with lubricants that comply with the specifications in the technical data.

Note that some lubricants may have properties that lie within the permitted limit values and yet not be suitable for use in centralized lubrication systems for other reasons. For example, some synthetic lubricants are not compatible with elastomers.

2.4 Lubricants and the environment

**DANGER!**

Lubricants can contaminate the ground and watercourses. Lubricants must be used and disposed of in compliance with the rules. Instructions and local regulations must be observed when handling lubricants.

Note that lubricants are harmful to the environment and flammable; their transportation, storage, and processing are subject to special precautionary measures. For specifications on transportation, storage, processing, and dangers to the use and the environment for the lubricant, refer to the material safety data sheet provided by or available from the lubricant manufacturer. You can ask the manufacturer of the lubricant for the material safety data sheet.

2.5 Danger relating to lubricants

**DANGER!**

Centralized lubrication systems must be absolutely leak-free. Leaking centralized lubrication systems can cause a slip hazard. When performing installation, maintenance, and repairs test the centralized lubrication system for leaks. Leaky parts of the centralized lubrication system or components of the lubrication equipment have to be sealed immediately.

Leaking centralized lubrication systems or components of the lubrication equipment are a source of danger in relation to slip hazard and the risk of injury. These dangers can cause physical injury to persons or damage to other material assets.

Refer to safety precautions in the lubricant manufacturer's material safety data sheet.

Lubricants are hazardous substance. It is essential to respect any safety instructions given in the lubricant safety data sheet. You can ask the manufacturer of the lubricant for the material safety data sheet.

3. Design and function

3.1 Versions

Motor-driven pumps GSE are available in different designs. They differ depending on the drum capacity and dimensions, on which they are mounted (→ **table 1**).

The motor-driven pump GSE can have a lubricant level monitoring device (pressure switch). A follower plate is fitted to the pump GSE in the case of a grease drum.

How your motor-driven pump is equipped is indicated on the nameplate and delivery papers. The adjacent table explains the type key.



If a motor-driven pump unit is not listed in table 1, please refer to the delivered technical sheet to know the specific technical data of the unit.

Table 1

Multi-outlet drum pumps GSE

Order No.	Drum capacity	Level monitoring	Follower plate	Cover
GSE0-25-00	25			
GSE0-25-01	25		•	•
GSE0-25-10	25			
GSE0-25-11	25	•	•	•
GSE0-25N-00	25			
GSE0-25N-01	25		•	•
GSE0-25N-10	25			
GSE0-25N-11	25	•	•	•
GSE0-50-00	50			
GSE0-50-01	50		•	•
GSE0-50-10	50			
GSE0-50-11	50	•	•	•
GSE0-50L-00	50			
GSE0-50L-01	50		•	•
GSE0-50L-10	50			
GSE0-50L-11	50	•	•	•
GSE0-200-00	200			
GSE0-200-01	200		•	•
GSE0-200-10	200			
GSE0-200-11	200	•	•	•

*) Please indicate the voltage key when ordering:

+140: 230/400 V AC, 50 Hz; +428: 230 V AC, 50/60 Hz; +924: 24 V DC

3.2 Construction

Figure 1 shows the essential design of the motor-driven pump GSE.

The main element of the motor-driven pump GSE is the pump housing with the eccentric cam in it. The gear motor on the back side of the pump housing drives the cam.

The pump housing is mounted on the suction pipe, which will be plunged into the drum. You can adjust the height of the suction pipe with a positioning wheel. In the case of a drum of grease, the pipe is equipped with a follower plate and a cover, which adapts itself to different drum sizes.

The pump elements, from 1 to 6, are fitted around the pump housing. There is a bleeding plug and the front side of the pump housing and you can extract the pump from the drum by means of the lift ring.

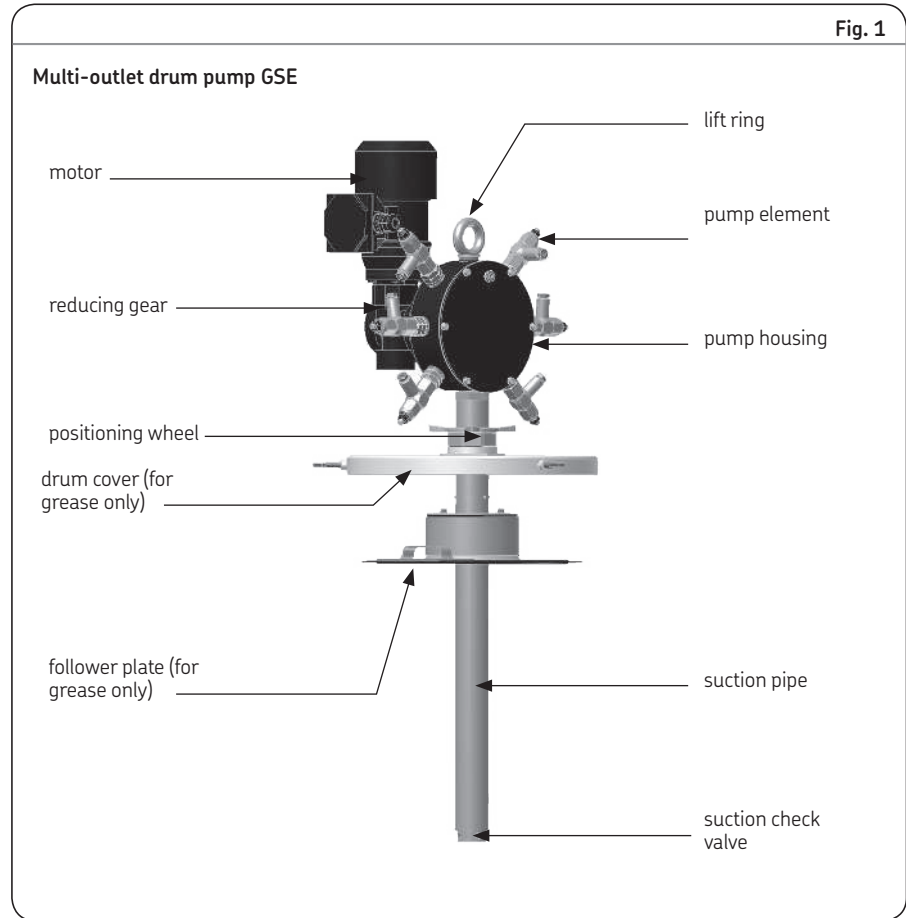

Fig. 2

Dimensions of the motor-driven pump unit GSE

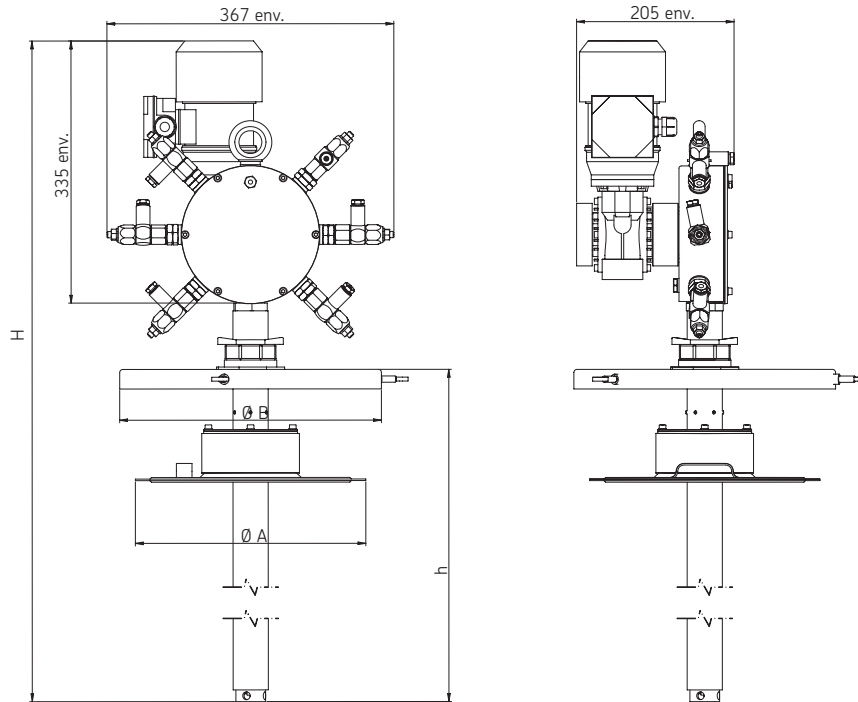

Table 2

Drum	Cover (drum OD)		Unit max. H
	min. $\varnothing B$	max. $\varnothing B$	
25 kg	265	310	935
25 kg N	285	305	935
50 kg	350	395	1,150
50 kg L	360	405	1,150
200 kg	565	610	1,340

Drum	Pipe drum) max. h	Follower plate (drum ID)	
		min. $\varnothing A$	max. $\varnothing A$
25 kg	480	260	298
25 kg N	480	300	340
50 kg	695	330	370
50 kg L	695	360	405
200 kg	890	550	590

3.3 Function

When the motor-driven pump GSE is switched on, the primary shaft of the gear motor (1/100) is driving a vertical shaft, on which an eccentric cam is mounted. This cam is in the pump housing. This cam actuates simultaneously:

- the control piston of the suction valve of the pipe,
- the pumping piston of the pump element.

The pipe sucks via the suction valve the lubricant in the drum and delivers it into the pump housing. A pressure switch, set at 0,3 bar, is inside the pump housing. It checks the pump housing is correctly fed up. When the pressure inside the pump housing drops the pressure switch sends a signal. The lack of pressure means that the drum is empty.

The pump elements are fitted around the pump housing. Every pump element is connected to the eccentric as the piston heel is put into the eccentric groove. Every rotation ($\approx 15 \text{ min}^{-1}$) of the eccentric actuates the pump elements. The pumping pistons suck the lubricant in the pump housing, which is the metered by the valve piston. The metered quantity of lubricant is then fed out

through the pump element outlet. The pump element outlet is either directly connected to a lubrication point, or to a primary line, which is delivering the lubricant to progressive feeders.

Control (manometer, pressure switches, flow indicators) and safety devices (over-pressure valve) have to be independently installed on every line in regard to the requirements and surrounding conditions of every lubrication point.

4. Installation instructions

The motor-driven pump unit described in the mounting instructions may only be installed, operated, maintained, and repaired by qualified experts. Qualified personnel are persons who have been trained, instructed, and familiarized by the user of the end product into which the system is installed. These persons are considered capable of such tasks due to their education, training, and experience with valid standards, conditions, accident prevention regulations in effect, and installation conditions. They should be able to carry out the required tasks and to recognize – and thus avoid – any dangers that might otherwise occur.

A definition of what constitutes a qualified person and who are unqualified persons are stipulated in DIN VDE 0105 and IEC 364.

Before installing/positioning the motor-driven pump unit, remove the packaging material and any transportation safety devices such as sealing plugs. Keep the packaging material until any and all problems have been clarified.

Country-specific accident prevention regulations and the operating and maintenance instructions for the operator must be ob-



CAUTION!

The motor-driven pump unit must not be tipped up or dropped!

served when carrying out all installation work on machines.

4.1 Positioning

The motor-driven pump must be protected from moisture and vibration, but on the other hand mounted so that it is easily accessible to ensure that all further installation work can be carried out without difficulty.

Ensure that there is adequate space for changing the drum when necessary.

The main lines to the lubrication points should be laid with an upward inclination if possible (air bleeding). Lubricant distributors at the end of the lubrication system should be installed with the lubrication point lines pointing upward.

Hand tighten the tube fittings, then tighten them by 1 1/2 turn.



DANGER!

The supply voltage on site must agree with the information on the codification of the motor-driven pump unit. Check the fusing of the circuit. Use only the original fuse with the required ampere value. If other fuses are used, damage to property or personal injury may be the consequence.

4.2.2 Installation

Install the motor-driven pump in the following order:

Follower plate (drum of grease)

- Remove the cover from the lubricant drum
- Press the follower plate onto the grease
- Correctly press on the follower plate in order to blow away the air beneath



Do not use buckled drums, as there is no guarantee for tightness.

Cover (drum of grease)

- Put the cover on the drum
- Fasten the cover with the three lock screws.

The GSE pump

- Loosen the positioning wheel on the cover
- Let slide the suction pipe into the drum and adjust the height
- The suction pipe has to come to a stop at the bottom of the drum
- Tighten the positioning wheel
- Mount the pump element (see the paragraph *Pump element assembly*)
- Connect the tubes
- Connect the electric items (motor and eventually pressure switch)

4.3 Pump element

The pump element type GS100.8._ is made of two different pistons: the valve piston and the pumping piston. The pump piston is building up the pressure inside the pump element. It is actuated (to-and-fro movement) by the eccentric as the heel of the piston is inserted into the groove of the eccentric.

The pump element has a check valve at the outlet connection.

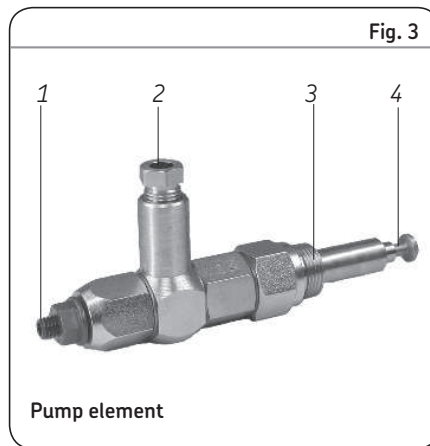

Table 3

Pump elements

Order No.	Pipe	Flow rate
	mm	cm ³ /stroke
GS100.8.6	Ø6	0 to 0,15
GS100.8.8	Ø8	0 to 0,15

Pumping element GS100...

- 1 – flow rate set screw
- 2 – outlet port
- 3 – fixing screw on pump housing + seal
- 4 – piston pump with heel

Pump element assembly

It is possible to mount up to 6 pump elements on the GSE unit.

There are six outlet ports radially placed around the GSE pump unit housing. The pump element can be mounted in one of these ports. It is directly connected to the eccentric by the groove.

- Screw off the closing plug (initial mounting) or the pumping element (replacing).
- Remove bothersome lubricant between the fixing thread and the groove.
- Pull out the piston of the new pump element as far as possible.
- Insert the pump element with a light upward inclination until the eccentric (→ **fig. 5**). The seal has to be between the pump element and the pump housing.
- Set the pump element horizontally such as the piston heel is coming into the eccentric groove (→ **fig. 6**).
- Screw in the pump element.

! Mount and dismount pump elements only when the unit is disconnected from power supply. Failure to comply with this requirement may lead to bodily injury or damage of the unit.

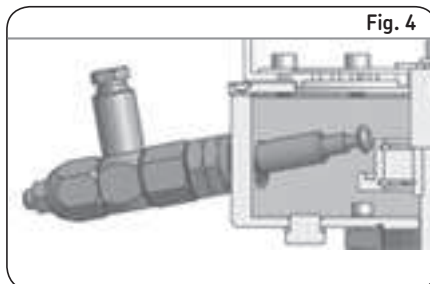

Fig. 4

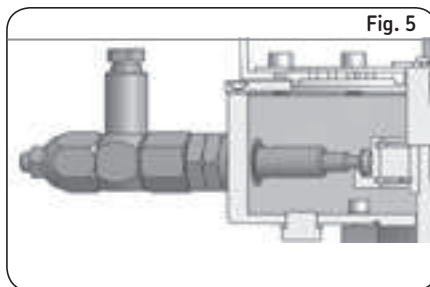
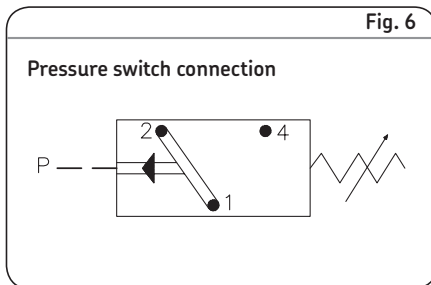

Fig. 5

4.5 Level monitoring

The level monitoring of a motor-driven pump unit is performed with a pressure switch located inside the pump housing.

The suction pipe of the motor-driven pump sucks the lubricant in the drum and delivers it into the pump housing. Pressure builds up inside the pump housing. When the drum is empty, the pressure in the pump housing relieves and drops under the pressure set at the pressure switch (0,3 bar). The pressure switch sends a signal to indicate the drum is empty.



5. Transport, delivery and storage

5.1 Transport

SKF products are packaged in accordance with the regulations of the recipient country and in accordance with DIN ISO 9001. Our products must be transported with care. Products must be protected against mechanical influences such as impacts. Transport packaging must be labeled with the information 'Do not drop!'.



The product must not be tipped up or dropped.

There are no restrictions relating to land, air, or sea transportation.

5.2 Delivery

Following receipt of the shipment, the product or products must be checked for damage and the shipping documents should be used to make sure that the delivery is complete. Keep the packaging material until any and all problems have been clarified.

5.3 Storage

The following conditions apply to the storage of SKF products.

5.3.1 Storage of lubrication units

- Ambient conditions: dry, dust-free environment; storage in well-ventilated, dry area
- Storage time: 24 months max.
- Permitted air humidity: < 65%
- Warehouse temperature: 10 – 40 °C
- Light: direct sunlight/UV radiation must be avoided; nearby sources of heat must be screened

5.3.2 Storage of electronic and electrical devices

- Ambient conditions: dry, dust-free environment; storage in well-ventilated, dry area

- Storage time: 24 months max.
- Permitted air humidity: < 65%
- Warehouse temperature: 10 – 40 °C
- Light: direct sunlight/UV radiation must be avoided; nearby sources of heat must be screened

5.3.3 Storage – general information

- Ensure that no dust gets into stored products by wrapping them in plastic film
- Store products on racks or pallets to protect them from damp floors
- Before placing products into storage, protect uncoated metal surfaces – and drive parts and mount surfaces in particular – from corrosion using long-term corrosion protection.

6. Activation

6.1 General

The motor-driven pump unit described operates automatically. However it is recommended that you regularly visually check the transport of lubricant in the lines and the lubricant projection at the nozzles.



You must observe the machinery manufacturer's information on the lubricants to be used in the machinery.



Lubricant should not be sprayed at a person nor on a hot/incandescent body.



CAUTION!

Only use a clean lubricant. Soiled lubricants can cause major defects in the system.



CAUTION!

Different lubricants must not be mixed together. Doing so can cause damage and require extensive cleaning of the motor-driven pump unit. To prevent any risk of error, it is recommended to clearly identify the lubricant used on the reservoir.



CAUTION!

Depending on the nature of the lubricant used, the user should wear protective equipment such as glasses, a mask and gloves. For further information please consult the technical file and the safety data sheet for the lubricant used.

6.2. Commissioning

Before starting the motor-driven pump unit check if all connections have been well mounted and tightened.

To ensure the good function of the lubrication system, it is recommended to prefill the different lubrication lines before to connect them to the motor-driven pump unit.

6.2.1 Motor-driven pump unit bleeding

- Set the pump element to the minimal flow rate
- Run the pump
- Screw off the bleeding plug, which is on the front of the pump housing
- Let run the pump until bubble free lubricant comes out
- Put back the bleeding plug

According to the viscosity of the lubricant and the height of the suction pipe, the delay of this operation is variable (up to 20 minutes in the most unfavorable case).

- Stop the pump

6.2.2 Bleeding the pump elements

For an easier priming bleed the pump elements. (→ fig. 7)

- Loosen the sealing nut (1)
- Loosen the clamping nut (3)
- Run the motor-driven unit until lubricant comes out of the swiveling connector (4)
- Stop the motor-driven unit
- Tighten the clamping nut (3)
- Tighten the sealing nut (1)
- Do the same for all pump elements
- Connect the main lines to the pump elements
- Set the pump elements to their maximal flow rate
- Let the motor-driven unit run until bubble-free lubricant comes out of the main lines connected to the pump elements
- Connect the main lines to the lubrication points or to the distributors

6.3 Flow rate adjustment

To adjust the pump element flow rate you need a 4 mm key for hexagon socket screw. (→ fig. 7)

A pumping element type GS100.8_ can deliver from 0 to 0,15 cm³ per stroke. A complete turn of the screw corresponds to a volume of 0,0625 cm³.

- Loosen the sealing nut (1)
- Turn the adjusting screw (2) clockwise with the key to reduce the flow rate.
- Turn the adjusting screw (2) counter-clockwise with the key to increase the flow rate.
- Loosen the sealing nut (1).

Fig. 7

4.3 Pump element bleeding

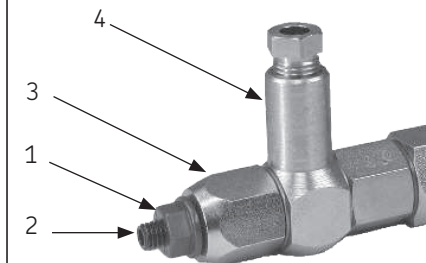
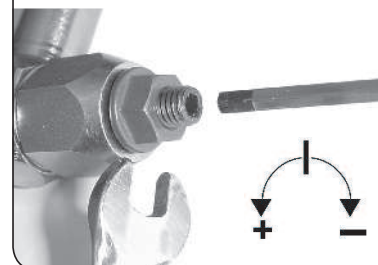

Fig. 8

Flow rate adjustment



6.5 Replacing the drum

- Switch off the motor-driven pump GSE
- Disconnect the pump elements
- Screw off the three clamping screw, which hold the cover on the drum
- Remove the pump and the cover** from the drum. Use the lift ring and a jib
- Lay the pump and cover on an even and clean surface to prevent any pollution
- Remove the follower plate from the rest of lubricant and take it out of the drum*
- Lay the follower plate on an even and clean surface to prevent any pollution*
- Put the follower plate in the new drum*
- Firmly press on the follower plate so that no air bubble is forming under it*
- Put back the cover and the pump on the drum The suction pipe must slide through the follower plate
- Fasten the cover on the drum with the three clamping screws
- If necessary adjust the height of the suction pipe. It has to come to a stop at the bottom of the drum. (see paragraph *Installation*)
- Bleed the pump housing and the pump elements (see paragraph *Commissioning*)
- Reconnect the main lines to the pump elements

- The installation is now ready to operate.

*) These procedures apply only in the case of grease drum.

**) In the case of the oil drum, the cover is often the one of the drum. It is then not necessary to remove it.

7. Shutdown

7.1 Temporary shutdown

You can temporarily shut down the described product by disconnecting the electrical and hydraulic connections. For more information, see the section *General information* in this manual.

If you wish to shut down the product temporarily, refer also to the instructions in the section *Transport, delivery, and storage* of this manual.

When placing the product back into operation, refer to the information in the sections *Installation* and *Commissioning* of this manual.

7.2 Permanent shutdown

All country specific legal guidelines and legislation on the disposal of contaminated equipment must be observed when shutting down the product for the final time.



Caution!

Lubricants can contaminate the ground and watercourses. Lubricants must be used and disposed of in compliance with the rules. Instructions and local regulations must be observed when handling lubricants.

The system can also be taken back by SKF for disposal if the costs are covered.

8. Maintenance



CAUTION!

Working on products that have not been disconnected from the power supply can cause serious injury or death to persons. Installation, maintenance, and repair work may only be carried out by qualified experts on a product that is not connected to a power supply. The supply voltage must be turned off before any product components are opened.



CAUTION!

The lubrication system may be under pressure. Centralized lubrication systems must therefore be depressurized before starting installation, maintenance, or repair work and before making any changes to the system.



CAUTION!

The described product may be under pressure when it is being operated. The product must therefore be depressurized before starting installation, maintenance, or repair work and before making any changes to the system.

The motor-driven pumps GSE are for the most part maintenance free. To ensure they work properly, however, please regularly check the following:

- If there is no monitoring device on the lines and after longer operation (max. 6 months), check the good function of the pump elements.
- Regularly check the lubricant level in the drum and replace it as soon as the minimal level has been reached.
- Check the pump regularly for external damages and leaks.
- All electrical connections and lines must be checked regularly for damage and to ensure that they are firmly in place.
- Any faults found must be properly rectified before the system is activated again.





You must not dismantle the product or parts of the product during the warranty period. Doing so invalidates all warranty claims.

Only original SKF spare parts may be used. It is prohibited for the operator to make alterations to the product or to use non original spare parts and resources. Doing so invalidates all warranty claims.

SKF is not liable for damage caused by improper installation, maintenance, or repair work.

9. Failures

Table 4 gives an overview of possible malfunctions and their causes. If you are unable to rectify the malfunction, please contact SKF Service Center.

-  You must not dismantle the product or parts of the product during the warranty period. Doing so invalidates all warranty claims.
-  All other work relating to installation, maintenance, and repair must only be carried out by SKF Service.
-  Only original SKF spare parts may be used. It is prohibited for the operator to make alterations to the product or to use non original spare parts and resources.

**CAUTION!**

Working on products that have not been disconnected from the power supply can cause serious injury or death to persons. Installation, maintenance, and repair work may only be carried out by qualified experts on products that are not connected to a power supply. The supply voltage must be turned off before any product components are opened.

**CAUTION!**

Centralized lubrication systems are under pressure when they are being operated. Centralized lubrication systems must therefore be depressurized before starting installation, maintenance, or repair work and before making any changes to the system.

Table 4**Failure analysis and remedy**

Failure	Possible cause	Solution
Not outflow at the operating pressure	Electric causes The motor does not run during the lubrication process	Check the motor power supply <ul style="list-style-type: none"> • voltage, connection and cable conformity Check the motor heat shield Replace the motor if necessary.
	Mechanical causes Pump element blocked	Remove the pump element Check the good function (easily sliding of the pistons – by hands). Remove and replace the pump element if necessary
Worn pump element		Replace it:
Hydraulic causes Too high pressure		Check the installation <ul style="list-style-type: none"> • blocked distributor • blocked lubrication point
Not enough lubricant in the drum		Replace the drum
Air in the drum		Bleed the pump and the pipes, and use a deaerated lubricant. Check if there is no air between the follower plate and the lubricant.
Unsuitable lubricant		Empty the whole installation and replace the lubricant

Technical data

Table 5

Motor-driven pump unit

Number of outlets	1 to 6
Flow rate per outlet	adjustable from 0,05 to 0,15 cm ³ /stroke
Number of strokes	≈ 15/min
Pressure max.	250 bar
Operating temperature	-10 to +40 °C
Lubricant (at operating temperature)	
– grease	up to NLGI grade ≤ 2
– oil	≥ 100 mm ² /s
Lubricant	grease NLGI grade 2
Outlet connector, orientable	connection for tube Ø8
Bleeding screw	H14
Material	
Pump element	steel and brass
Housing	aluminum
Suction pipe	galvanized steel
Acoustic emission	≤ 70 dB (A)

Level monitoring – pressure switch

Switching capacity	250 V / 4 A
Voltage max.	250 V
Intensity max.	0.5 A
Protection	IP 65
Connector	DIN 43650
Cable gland	CM8

Table 6

Motor of the pump unit

Voltage key	Voltage [V]	Frequency [Hz]	Power [W]	Current [A]	Rotation speed [rpm]	Protection	Reduction	Class
+140	230/400 V AC	50	90	0,59/0,34	1 500	IP 55	F/vented	
+428	230 V AC	50/60	90	1.1	1 500	IP 55	F/vented	
+924	24 V DC	–	90	6	1 500	IP 55	not vented	

*) Low voltage directive 73/23/EEC – Norm EN 60439

**) At 60 Hz rotation speed is multiplied by 1,2

11. Spare parts and accessories



Only original SKF spare parts may be used. It is prohibited for the operator to make alterations to the product or to use non original spare parts and resources.

Table 7

List of spare parts

Order No.	Designation
G SJ1115-RE	Outlet plug HC – M20×1,5 with washer
G SJ1111+140	Gear motor 230/400 V three-phase, 50 Hz
G SJ1111+428	Gear motor 230 V single phase, 50 Hz
G SJ1111+924	Gear motor 24 V DC
AC-4261-W	Pressure switch
G S100.8.6	Pump element, piston Ø8, tube connection Ø6
G S100.8.8	Pump element, piston Ø8, tube connection Ø8
G SE1028-RE2	Seal kit

List of accessories

Order No.	Designation
PT.120.25	Cover for 25 kg drum
PT.120.25N	Cover for 25 kg drum
PT-130-50	Cover for 50 kg drum
PT.120.50L	Cover for 50 kg wide drum
PT.120.200	Cover for 200 kg drum
G SE1008-25	Follower plate for 25 kg drum
G SE1008-25N	Follower plate for 25 kg drum
G SE1008-50	Follower plate for 50 kg drum
G SE1008-50L	Follower plate for 50 kg wide drum
G SE1008-200	Follower plate for 200 kg drum
PT-1028	Lift jib

SKF France

Lubrication Product Division
Bld Charles de Gaulle, B.P. 239
37540 St-Cyr-sur-Loire – FRANCE
Tel. +33 (0) 247 403 087
lubrication-france@skf.com

! Important information on product usage

SKF and Lincoln lubrication systems or their components are not approved for use with gases, liquefied gases, pressurized gases in solution and fluids with a vapor pressure exceeding normal atmospheric pressure (1 013 mbar) by more than 0,5 bar at their maximum permissible temperature.

© SKF is a registered trademark of the SKF Group.

© SKF Group 2016

The contents of this publication are the copyright of the publisher and may not be reproduced (even extracts) unless prior written permission is granted. Every care has been taken to ensure the accuracy of the information contained in this publication but no liability can be accepted for any loss or damage whether direct, indirect or consequential arising out of the use of the information contained herein.

PUB 951-130-407/3 EN • June 2016

