

SKF high temperature bearings

For operating temperatures up to 350 °C (660 °F)

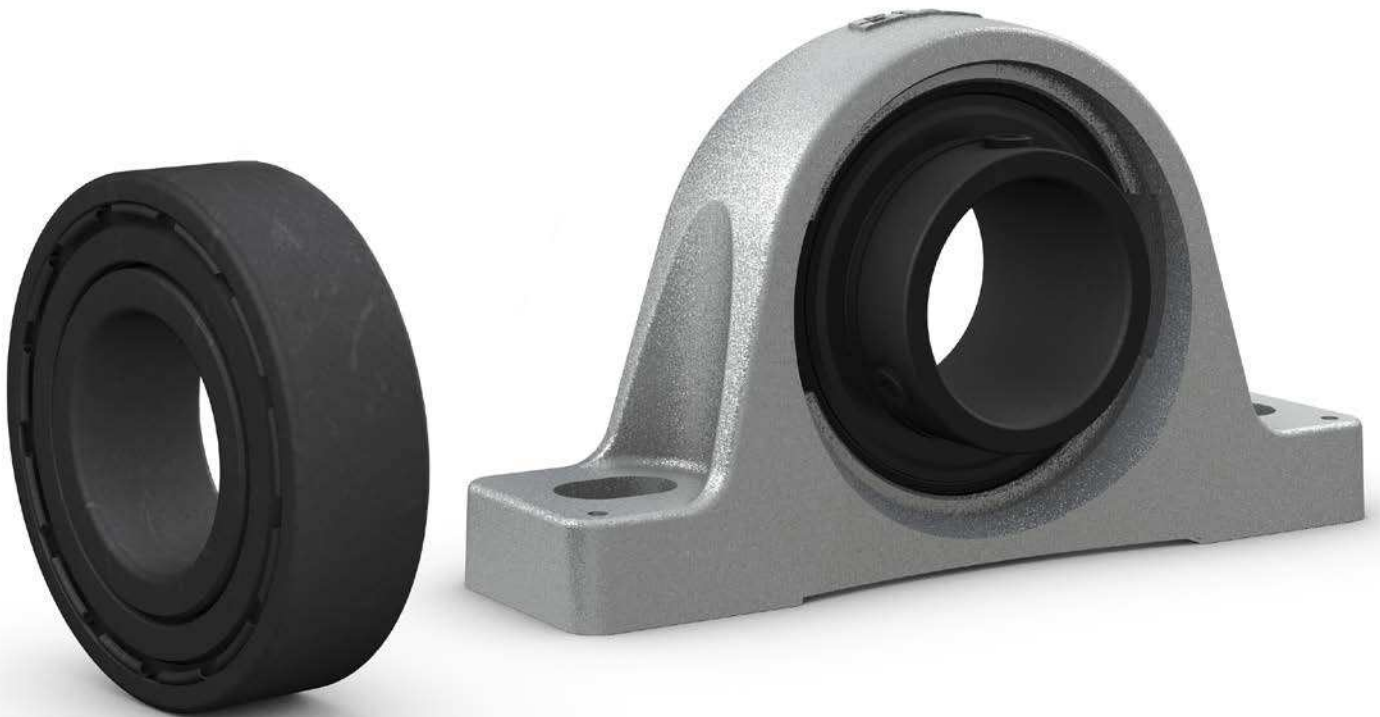

Contents

Reduce maintenance. Run Longer. Run Cleaner.	3
SKF high temperature bearings run trouble-free	3
Common issues in high temperature applications	4
The SKF high temperature bearing solution	4
The SKF advantage: optimum performance, efficiency and savings	4
Customer benefits.	5
Proven performance across industries	6
Cooling bed for steel plates.	6
Continuous baking ovens	7
Wafer baking ovens.	8
Paint lines	9
Assortment.	10
Deep groove ball bearings for high temperature applications. . . .	12
Insert bearings and ball bearing units for high temperature applications.	13
Lubrication and running in	15
Loads and selecting bearing size	15
Design of bearing arrangements	16
Bearing data	18
Product tables	
Deep groove ball bearings for high temperature applications. . . .	20
Insert bearings for high temperature applications, metric shafts .	24
Insert bearings for high temperature applications, inch shafts . . .	25
Ball bearing plummer (pillow) block units for high temperature applications, metric shafts, ISO	26
Ball bearing plummer (pillow) block units for high temperature applications, inch shafts, ISO	28
Ball bearing square flanged units for high temperature applications, metric shafts, ISO	30
Ball bearing square flanged units for high temperature applications, inch shafts, ISO	32
Ball bearing oval flanged units for high temperature applications, metric shafts, ISO	34
Ball bearing oval flanged units for high temperature applications, inch shafts, ISO	36

Reduce maintenance. Run longer. Run cleaner.

Bearings operating in high temperature applications can be unreliable due to premature failure. The result is high costs and time wasted on frequent bearing replacements. SKF offers a solution with an assortment of bearings designed to reduce maintenance, run longer and cleaner in high temperature applications.

SKF high temperature bearings run trouble-free

SKF high temperature bearings incorporate a graphite-based lubrication that continuously lubricate the bearing, eliminating the use of grease and oil. Ideal for applications in industries such as metals and food & beverage, these bearings are designed for trouble-free operation at temperatures up to 350 °C (660 °F).

SKF high temperature bearings provide:

- Reduced total operating cost through increased bearing service life
- Relubrication-free operation
- Reduced machine complexity
- Reduced environmental impact
- Excellent performance in hot conditions, dry environments and applications with low rotational speeds



Common issues in high temperature applications

Bearings operating in high temperature applications may be impacted by a number of factors that can reduce bearing service life. Common issues include:

Inadequate lubrication

At high temperatures, lubricating grease or oil becomes very thin. Oil that is too thin, in combination with low rotational speeds, results in metal-to-metal contact in the bearing. This will cause wear, leading to noise and excessive play (→ fig. 1).

Short grease life

Grease ages rapidly at high temperatures, resulting in the need for very frequent relubrication. This is time consuming and costly and is a task that can be forgotten or even neglected. Frequent relubrication also creates the potential to over-fill the bearing, increasing the risk of excess grease contaminating the process and possibly catching fire. Additionally, old grease left in the bearings can carbonize at high temperatures and block the bearings (→ fig. 2).

Loss of internal bearing clearance

When temperatures rise above the bearing stabilization temperature, thermal expansion and material structural changes will occur in the bearing. This can lead to an uncontrolled loss of internal radial clearance, and ultimately seized bearings (→ fig. 3).

The SKF high temperature bearing solution

SKF high temperature bearings are designed for challenging operating conditions, with variants capable of performing at temperatures as high as 350 °C (660 °F). These bearings incorporate graphite-based lubrication which can lubricate at high temperatures and low speeds, eliminating the risk of metal-to-metal contact. Unlike grease and oil, graphite does not age and will not lose its lubricating properties at temperatures up to 350 °C (660 °F). This eliminates the need to relubricate SKF high temperature bearings. Additionally, these bearings are designed with a special radial clearance specified to maintain the required radial clearance at high operating temperatures. This avoids bearing seizure and enables a long service life.

The SKF advantage: optimum performance, efficiency and savings

SKF high temperature bearings are designed to deliver increased reliability, reduced complexity, and decreased environmental impact. Because high temperature bearings correspond to the ISO boundary dimensions for standard bearings, production efficiencies and cost savings can be realized with a simple change to SKF high temperature bearings.

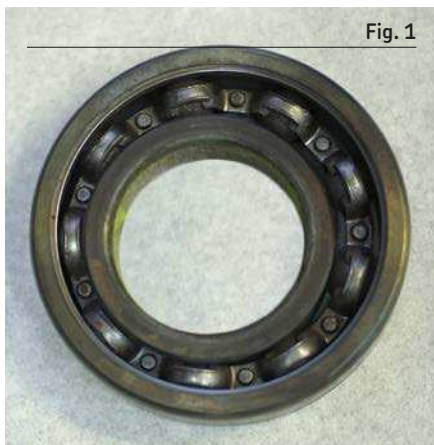

Inadequate lubrication cause wear which can be recognized by noise and excessive play



Grease can carbonize and block the bearing at high operating temperatures



Loss of internal radial clearance leading to a seized bearing

Customer benefits

Increased reliability, reduced maintenance

By eliminating temperature related bearing failures, SKF high temperature bearings improve machine uptime, output and overall reliability. The SKF solution also eliminates the need to frequently relubricate bearings operating at high temperatures. This provides greater peace of mind, while enhancing operational efficiencies and cost savings.

Reduced complexity

Because SKF high temperature bearings are designed for relubrication-free operation at temperatures up to 350 °C (660 °F), manual and automatic lubrication systems are eliminated along with their related costs and issues. Complex cooling systems used to reduce bearing operating temperatures may also be unnecessary.

Reduced environmental impact

Global factors

These products are designed to reduce environmental impact and contribute to sustainability efforts (→ diagram 1).

Workplace and process safety

With grease removed from the process environment, relubrication procedures in potentially dangerous areas of the operation can be avoided. Slippery surfaces from grease leakage and the risk of excess grease catching fire are eliminated. SKF high temperature bearings also contribute to food safety, because there is no risk of process lines and products being contaminated by grease.

Diagram 1

SKF high temperature bearings reduce CO2-emissions in a cooling bed for steel plates

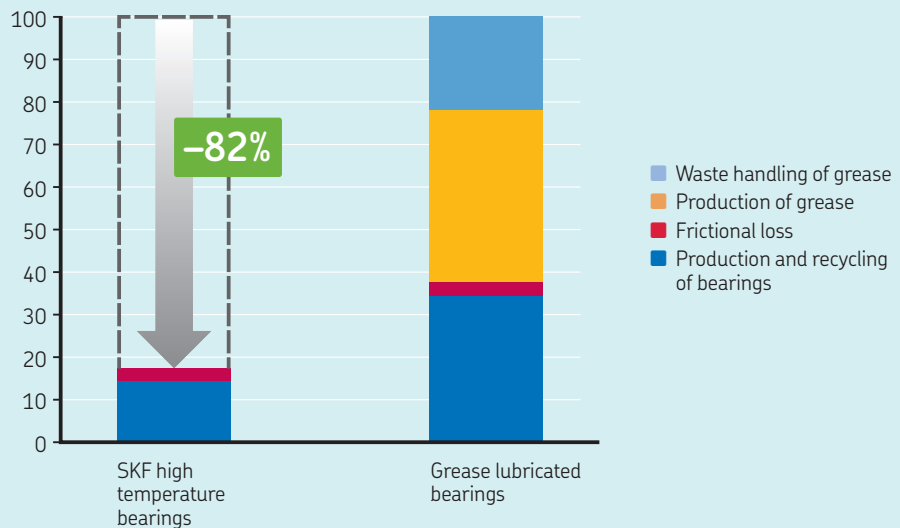

Environmental impact of SKF high temperature bearings compared to grease lubricated bearings

Proven performance across industries

SKF high temperature bearings provide solutions that are proven in a number of different applications across a variety of industries. Even if the design and purpose of the bearing applications differ greatly, they all share common operating conditions that are ideal for graphite lubrication. Examples of successful installations are shown on the next few pages.

Cooling bed for steel plates

In hot rolling mills, extremely large cooling beds accumulate and allow steel plates to cool. They use thousands of bearings, operating in intense heat standing still or rotating very slowly. A customer operating this application was using grease lubricated deep groove ball bearings with C4 radial clearance.

Customer issues

The large number of bearings required large amounts of grease, making relubrication costly, difficult and time consuming.

Rollers that would not rotate due to seized bearings created scratches on the steel plates. Replacing failed bearings was causing costly downtime.



A large cooling bed for steel plates. Each wheel is supported by four high temperature bearings.

Customer case

Grease-lubricated, deep groove ball bearings were replaced with SKF high temperature bearings. A total of 5 000 SKF bearings were installed. Performance improvements were immediately realized, including:

- Bearing service life increased from six months to more than six years
- Return on investment achieved in eight months
- Savings realized through eliminating grease purchase and waste handling costs
- Reduced maintenance time and costs
- Improved product quality (scratch marks eliminated)
- Reduced bearing related CO₂ emissions by 82%



SKF 6212-2Z/VA228 high temperature bearings are an outstanding solution for cooling beds.

Continuous baking ovens

Continuous baking ovens are used by large-volume industrial bakeries. Requirements for throughput and reliability are very high. Bearings rotate slowly and are exposed to high temperatures. A customer was using grease-lubricated ball bearing units in a continuous baking oven.

Customer issues

High operating temperatures caused inadequate lubrication, increased wear in the bearings, poor reliability, unplanned stops and ultimately failure. Frequent relubrication using expensive high temperature grease required costly maintenance, while used grease ejected from the bearings created a risk of food contamination and worker safety issues.



Continuous baking oven using high temperature ball bearing units to support the belt.

Customer case

The grease-lubricated bearing units were replaced with SKF high temperature ball bearing units, resulting in a number of performance and productivity enhancements, including:

- Bearing service life extended from 6 to 36 months
- Return on investment achieved in less than eight months
- SKF solution is NSF H1 certified
- High temperature bearings enabled higher process temperatures resulting in higher output
- Significantly improved reliability
- Maintenance costs reduced
- Food and worker safety improved due to the elimination of grease



SKF high temperature ball bearing units FY 25 TF/VA228 can enable higher output and reduced costs in food and beverage operations.

Wafer baking ovens

Producers of confectionary products use fully automated wafer baking ovens for high-volume production. A food and beverage manufacturer running this process was using deep groove ball bearings lubricated with high temperature grease.

Customer issues

Bearing relubrication was needed every 16 weeks, requiring costly planned maintenance. Grease leakage impacted food safety. Output was limited by the oven temperature restrictions of grease-lubricated bearings.

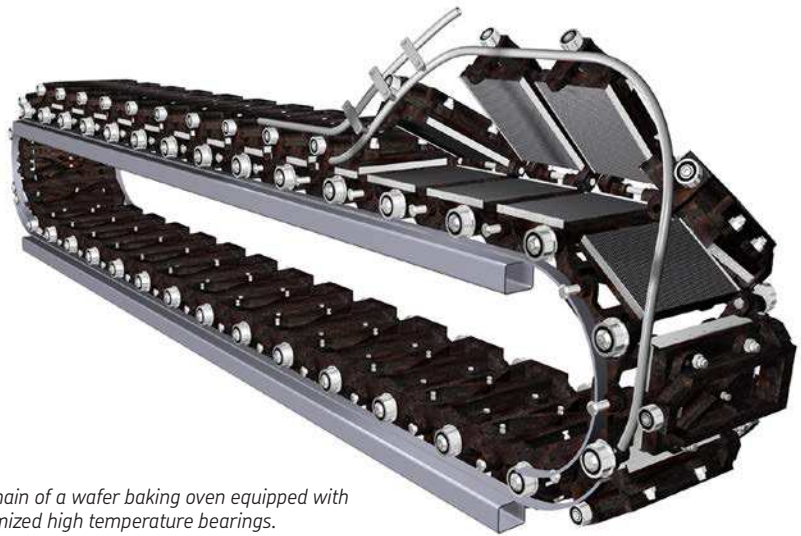

The chain of a wafer baking oven equipped with customized high temperature bearings.



*SKF high temperature flanged carrier wheel units and smaller top roller units without a flange offer relubrication-free performance and reliability in automatic wafer baking ovens.
BB1-5098 B (top roller)
BB1-5067 B (carrier wheel)*

Customer case

SKF high temperature wafer units were installed. These bearings incorporate graphite-based lubrication that continuously lubricates the bearing. Cost effectiveness and productivity were improved through benefits including:

- The relubrication-free wafer units ran for 5 years 24/7
- Eliminated costs for high temperature grease
- Eliminated 150 hours of labour annually
- 26 hours of planned downtime every 16 weeks was eliminated, increasing productivity through reduced maintenance
- Increased output, as graphite lubrication allows for higher process temperature
- Food and worker safety improved, due to eliminated consumption of grease

Paint lines

Paint lines are conveyor systems that transport parts as they are painted and dried. For one customer, the bearing operating temperature in the drying section was up to 200 °C (390 °F). Deep groove ball bearings lubricated with high temperature grease needed frequent relubrication.

Customer issues

Painted car chassis frequently needed to be reworked due to paint damage caused by lubricant leakage from the bearings. Grease could stain the drying paint, an issue made worse when water-based paints were used. The high temperature greases used were not PWIS-free (Paint-Wetting Impairment Substances). Damage to the paint on chassis parts caused production stops.



Paint line conveyors are supported by wheels equipped with graphite lubricated bearings.

Customer case

The grease-lubricated bearings were replaced with SKF high temperature bearings. Quality and productivity in the paint line was significantly improved, with results including:

- Reduction in the number of chassis needing rework
- Significant increase in paint line efficiency
- Reduced downtime

SKF high temperature bearings are available in versions that apply to common PWIS standards.



SKF 6205-2Z/VA292 high temperature bearings offer a PWIS-free solution for paint-line drying processes.

Assortment

SKF offers a wide assortment of high temperature bearings and units according to ISO standards and also an assortment of customized high temperature bearings.

Selection of an appropriate high temperature bearing is based on the bearing type and the operating conditions (primarily the temperature and speed) of the machinery.

The SKF basic assortment of high temperature bearings and bearing units corresponding to ISO standards includes:

- Deep groove ball bearings
- Insert bearings
- Ball bearing units

The assortment includes variants that contain food-grade solid lubricants registered by NSF as category H1 (lubricant acceptable with incidental food contact for use in and around food processing areas).

In paint line applications, it is critical that the paint quality of the end product is not impaired by contamination. To address this need for high temperature paint lines, SKF offers a high temperature bearing variant VA292 that has the same bearing characteristics as version VA228 (→ **table 1, page 12**) but, in addition, comply with common PWIS standards (Paint Wetting Impairment Substance).

Customized high temperature bearings

In addition to high temperature bearings corresponding to ISO standards, SKF offers an assortment of customized high temperature bearings.

These bearings are customized for use in equipment such as automatic wafer baking ovens in the food and beverage industry, in industrial furnaces and in chains like customized cam rollers. For additional information, contact SKF.



Deep groove ball bearing



Cam roller



Ball bearing unit

Ideal operating conditions for SKF high temperature bearings

SKF high temperature bearings are designed to provide solutions to common issues in high temperature applications. In addition to operations involving high temperature, it is important to consider environmental conditions in the process area and the rotational speed of the shaft.

SKF high temperature bearings are an excellent choice for applications operating in hot environments with dry conditions and low rotational speeds. The hot, dry and slow criteria can be used as a rule of thumb for evaluating the use of graphite-lubricated bearings.



Hot:

Hot refers to operating temperatures up to 350 °C (660 °F) where grease-lubricated bearings often have a short service life. SKF high temperature bearings offer exceptional performance in positions affected by high operating temperatures.



Dry:

Due to very limited protection against corrosion, graphite-lubricated bearings must be kept dry.



Slow:

In slowly rotating applications running at high temperatures, oil and grease lubricants become too thin to generate a lubrication film of sufficient thickness to prevent metal-to-metal contact. SKF graphite-lubricated bearings are designed to handle these conditions.

Deep groove ball bearings for high temperature applications

The SKF range of deep groove ball bearings for high temperature applications provides solutions for various combinations of operating temperature and speed. All variants are lubricated for the life of the bearing, except for open VA201 bearings (that is, without integral shields) which require relubrication.

VA228 – SKF highest performance at temperatures up to 350 °C (660 °F)

VA228 is an excellent choice for machinery operating with low speeds or oscillating movements in combination with very high operating temperatures. This bearing offers outstanding performance at temperatures up to 350 °C (660 °F) through the combination of the solid graphite cage, an adjusted high temperature bearing radial internal clearance and integral shields.

VA208 – Improved performance at temperatures up to 350 °C (660 °F)

The VA208 bearing is lubricated by a segmented graphite cage. The large amount of lubricating graphite gives a long service life at temperatures up to 350 °C (660 °F).

VA201 – Basic performance at temperatures up to 250 °C (480 °F)

The VA201 bearing is lubricated with a polyalkylene glycol/graphite mixture suitable for temperatures up to 250 °C (480 °F). Version VA201 is an open bearing (without shields) while the 2Z/VA201 has an integral shield on both sides. Both versions are supplied pre-filled with lubricant. VA201 can be re-lubricated whilst 2Z/VA201 is lubricated for the life of the bearing. Depending on the speed and operating temperature, a special running-in procedure might be required (→ *Lubrication and running in*, page 15).

Features and benefits of high temperature deep groove ball bearings

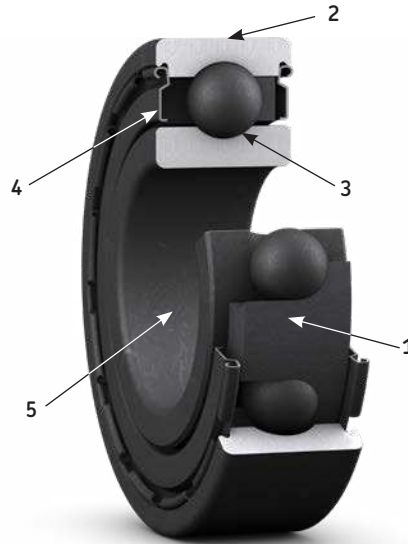

- 1 no need for relubrication¹⁾**
– the bearings are lubricated with graphite-based high temperature lubricants and are lubricated for the life of the bearing
- 2 simple replacement**
– the boundary dimensions are the same as those of standard bearings
- 3 operating temperature up to 350 °C (660 °F)**
– the internal radial clearance and the lubricant are optimized for operation at high temperatures
- 4 protection against contamination**
– shields (designation suffix 2Z) protect the bearing
- 5 improved running in**
– the entire bearing surface is manganese phosphate coated

¹⁾ All variants, except for VA201 open bearings (that is, without integrated shields), are lubricated for the life of the bearing

Table 1

Characteristics of high temperature variants for deep groove ball bearings

Characteristic	Variant VA201	VA208	VA228
Lubrication type	Polyalkylene glycol/graphite mixture	Segmented cage made of graphite	Coronet cage made of graphite
Phosphated rings, rolling elements and cages	yes	yes	yes
NSF H1 food grade	no	yes	yes
Shields (designation suffix 2Z)	yes / no (open bearing)	yes	yes
Relubrication free	yes / no (open bearing)	yes	yes
Maximum operating temperature	250 °C (480 °F)	350 °C (660 °F)	350 °C (660 °F)
Limiting speed [r/min]¹⁾	4 500/d _m	4 500/d _m	9 000/d _m
Running in required	Yes	No	No

¹⁾ d_m = bearing mean diameter = 0,5 (d + D). For outer ring rotation, use d_m = D.

Insert bearings and ball bearing units for high temperature applications

The SKF assortment of insert bearings and ball bearing units for high temperature applications, provides solutions for various temperature and speed combinations. Ball bearing units are available in three different designs in ISO standards. All variants are lubricated for the life of the bearing.



ISO standard designs

Features and benefits of high temperature ball bearing units

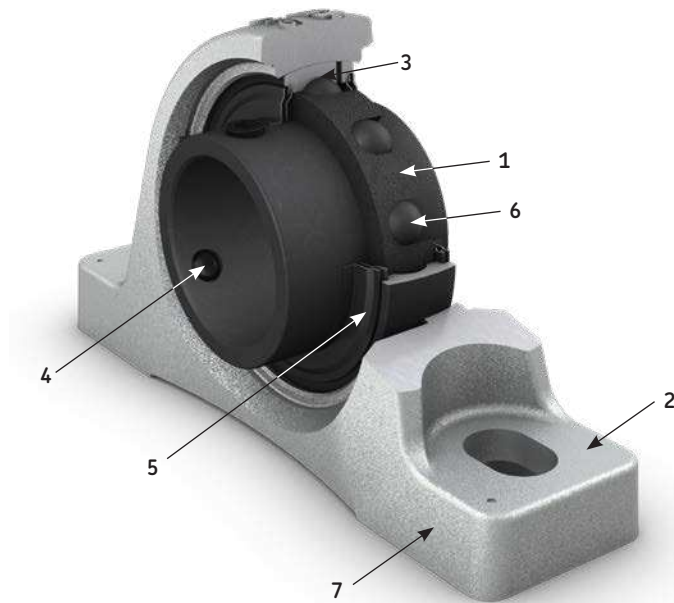

- 1 No need for relubrication**
– the bearings are lubricated with graphite-based high temperature lubricants and, as such, are lubricated for the life of the bearing
- 2 Simple replacement**
– the boundary dimensions are the same as those of standard bearings and units
- 3 Operating temperature up to 350 °C (660 °F)**
– the radial internal clearance and the lubricant are optimized for operation at high temperatures
- 4 Simple mounting and dismounting**
– the grub (set) screws in the inner ring make mounting/dismounting easy
- 5 Protection against contamination**
– shields and flingers (designation suffix 2F) protect the bearing
- 6 Improved running in**
– the entire bearing surface is manganese phosphate coated
- 7 No colour flaking**
– the housing is coated with a high temperature resistant coating



VA228 – SKF highest performance at temperatures up to 350 °C (660 °F)

VA228 is an excellent choice for machinery operating with low speeds or oscillating movements in combination with very high operating temperatures. This bearing offers outstanding performance at temperatures up to 350 °C (660 °F) through the combination of the solid graphite cage, an adjusted high temperature bearing radial internal clearance and integral shields and flingers.

VA201 – Basic performance at temperatures up to 250 °C (480 °F)

The VA201 bearing is lubricated with a polyalkylene glycol/graphite mixture suitable for temperatures up to 250 °C (480 °F). This bearing is pre-filled and lubricated for the life of the bearing. A special running-in procedure is needed for lower temperature applications (→ *Lubrication and running in*, page 15).

Table 2

Characteristics of high temperature variants for insert bearings and ball bearing units

Characteristic	Variant VA201	VA228
Lubrication type	Polyalkylene glycol/graphite mixture	Coronet cage made of graphite
Phosphated rings, rolling elements and cages	yes	yes
NSF H1 food grade	no	yes
Shields (suffix 2F)	yes	yes
Relubrication free	yes	yes
Maximum operating temperature	250 °C (480 °F)	350 °C (660 °F)
Limiting speed [r/min]¹⁾	4 500/d _m	9 000/d _m
Running in required	Yes	No

¹⁾ d_m = bearing mean diameter = 0,5 (d + D).

Lubrication and running in

Relubrication

All SKF high temperature deep groove ball bearings are lubricated for the life of the bearing, except for open VA201 bearings, which require relubrication.

The general recommendation for an open VA201 bearing is to investigate the quality of the lubricating paste in the bearing every six months. If there is no longer a film of dry lubricant on the raceways, indicated by a bright metallic shiny track, remove residues of the old lubricant with a solvent and, when dried, replenish the bearing with lubricating paste.

Apply the paste in a thin layer. The paste should be evenly distributed around the entire raceways of the bearing, which can be done using a brush of medium hardness. It is important to rotate the bearing when it has been replenished with paste. Any collars of excess paste should be removed.

Running in

Following installation or relubrication, VA201 bearings operating at bearing temperatures below 200 °C (390 °F), while running at speeds below 25% of the limiting speed require running in.

Running in requires that the bearing be run at a temperature of at least 200 °C (390 °F) for a minimum of 48 hours.

Loads and selecting bearing size

The bearing size is selected based on the basic static load rating C_0 . Basic static load ratings for bearings are listed in the product tables.

For an equivalent static bearing load P_0 , the selected bearing must have a C_0 value \geq the value of requisite basic static load rating C_{0req} specified in **table 3**.

NOTE: Table 3 is valid for high temperature deep groove ball bearing units and insert bearings only when

$$P_0 = F_r$$

That is, when:

$$F_a < 0,8 F_r$$

and

$$F_a < 0,15 C_0$$

where

P_0 = equivalent static bearing load [kN]

F_a = axial load [kN]

F_r = radial load [kN]

C_0 = basic static load rating [kN]

Table 3

Requisite basic static load rating for applied equivalent static bearing load

Equivalent static bearing load P_0	Requisite basic static load rating C_{0req} for operating temperatures up to	
	250 °C (480 °F)	350 °C (660 °F)
kN	kN	
2	6	9
4	11	18
6	16	27
8	22	36
10	27	45
15	40	67
20	54	90
25	67	120
30	80	140
40	110	180
50	140	230
60	160	270
70	190	320
80	220	360
90	240	400
100	270	450
125	340	560
150	400	670
200	540	890
300	800	1 400
400	1 100	1 800
500	1 400	2 300
600	1 600	–

Design of bearing arrangements

Location of bearings

The selection of shaft and housing fits for high temperature deep groove ball bearings depends on the bearing operating condition and bearing size. An appropriate fit is needed to locate the shaft, provide satisfactory support, allow for thermal expansion and reach the stated maximum operating bearing temperature (→ table 4).

For moderate loads ($0,035 C < P \leq 0,05 C$), the shaft seats for insert bearings should be machined to a $h7\text{E}$ tolerance. For light loads and low speeds, a $h8\text{E}$ shaft tolerance is sufficient.

All ISO tolerance classes are valid with the envelope requirement in accordance with ISO 14405-1.

Mounting

SKF high temperature insert bearings and ball bearing units have a clearance fit for the recommended shaft diameters. They can therefore be slid into position and secured with the grub (set) screws on the inner ring.

SKF high temperature bearings (except high temperature insert bearings and ball bearing units) should always be hot mounted

to reduce the mounting force and the risk of cracking the graphite lubricant. Induction heater is the preferred choice to heat the bearing during mounting.

Submerging the SKF high temperature bearings in hot oil is not recommended since the oil remaining in the bearing might carbonize later during operation. Do not use impact mounting methods such as hammer or bearing fitters because the impacts can make the graphite lubricant crack.

Operating environment

Since all high temperature bearings are supplied without preservative oils and must be used without grease or oil lubrication, the anti-corrosion property of the bearings is limited. Therefore, the bearings should be used in a dry environment or with a proper sealing arrangement to keep the bearings dry.

The most common sealing alternatives for high temperature deep groove ball bearings incorporate integral or external shields or labyrinth seals. These arrangements have a rather low complexity and none of these arrangements are capable of keeping the bearing dry in a wet environment.

Sealing solutions

High temperature deep groove ball bearings can be protected from contaminants by either integral shields, external shields or a combination of both.

For high temperature bearings, metallic shields are the primary recommendation when a capping device with low complexity is required. Shields prevent the ingress of solid contaminants into the bearing. They are non-contact, generate almost no friction and do not wear. Due to the material and design, they are particularly well suited for high temperatures.

High temperature deep groove ball bearings with designation suffix 2Z have integrated shields, but the VA201 variant is also available as an open bearing (→ fig. 2). The shields on a 2Z/VA201 bearing enable the bearing to be filled with twice the amount of polyalkylene glycol/graphite lubricant that is used in an open VA201 bearing.

The capping device on high temperature insert bearings (designation suffix 2F) consists of a shield and a flinger that create a narrow gap labyrinth seal (→ fig. 1).

Fig.1

High temperature insert bearings with integrated shields and flingers (2F)

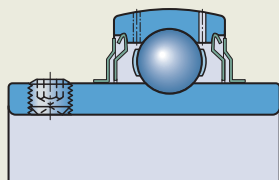

2F/VA201

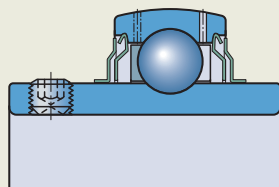

2F/VA228

Table 4

Fits for high temperature ball bearings on solid steel shafts or in cast iron and steel housings

Conditions	Shaft diameter	Shaft tolerance	Housing tolerance
–	mm	–	–
Rotating inner ring load	all	$k6\text{E}$	$F7\text{E}$
Stationary inner ring load	all	$g6\text{E}$	$J7\text{E}$

Fig. 2

High temperature deep groove ball bearings and integrated shields (2Z)

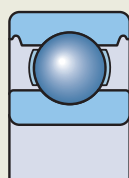

VA201

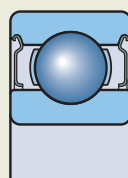

2Z/VA201

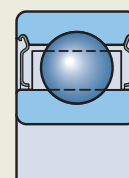

2Z/VA208

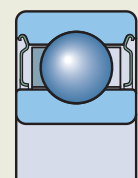

2Z/VA228

In many cases, the integral shields are sufficient to keep contaminants out of the bearing. However, in some cases, the integrated shields are insufficient, and so additional external shields should be considered – either Nilos rings (→ fig. 3), SKF sealing washers (→ fig. 4) or custom made seals.

Thermal axial expansion of shaft

To accommodate thermal axial expansion of the shaft in ball bearing unit arrangements, the shaft on the non-locating side should be provided with either one, or two grooves located 120° apart, to engage with modified grub screws:

- Hexagon socket grub (set) screws with a dog point, in accordance with ISO 4028, but with a fine thread according to **table 5**. The grub screw should be secured by a nut and spring washer or star lock washer (→ fig. 5).
- Slotted pan head screws in accordance with ISO 1580, but with fine thread according to table 5, locked with a spring or star lock washer (→ fig. 6).

The screws and groove(s) accommodate changes in shaft length and prevent the shaft from turning independently of the bearing inner ring. The ends of the grub screws should be ground and the sliding surfaces in the shaft grooves coated with a lubricant paste suitable for the operating temperature.

Fig. 3

Sealing solution using Nilos rings

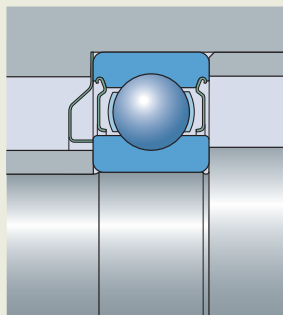
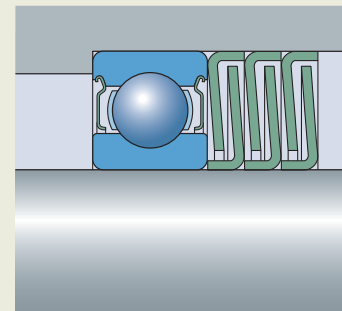

Fig. 4

Sealing solution using SKF sealing washers



Example showing bearing 6205-2Z/VA201 and triple sealing washers Z 205

Fig. 5

Hexagonal socket grub screw with a dog point secured by a nut and spring washer

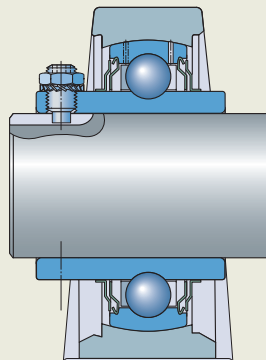

Fig. 6

Slotted pan head screw secured by a spring washer

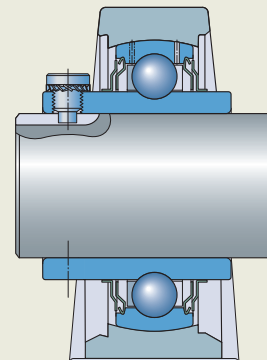

Table 5

Grub screw key sizes and recommended tightening torques

Bearing bore		Threaded holes	Hexagonal key size	Tightening torque
over	incl.			
mm/in.		–	mm/in.	Nm
For metric shaft				
–	35	M 6 x 0,75	3	4
35	45	M 8 x 1	4	6,5
45	80	M 10 x 1	5	16,5
For inch shaft				
–	1 3/16	1/4 – 28 UNF	1/8	4
1 3/16	1 3/4	5/16 – 24 UNF	5/32	6,5
1 3/4	2 7/16	3/8 – 24 UNF	3/16	16,5
2 7/16	2 15/16	7/16 – 20 UNF	7/32	28,5

Bearing data

	Deep groove ball bearings	Insert bearings	Ball bearing units
Dimension standards	Boundary dimensions: ISO 15 Series 10, 02, 03	Boundary dimensions: ISO 9628	Boundary dimensions: ISO 3228
Tolerances	Normal Values: ISO 492	Normal, except the bore and outside diameter (→ table 6) Values: ISO 492	Housing bore has an increased sphere diameter appropriate for high temperature applications.
	Due to the special surface treatment of the bearings and the insert bearing housings, there may be slight deviations from the standard tolerances. These deviations do not affect mounting or bearing operation.		
Radial internal clearance	Multiples of C5		
	Values (table 7) are valid for unmounted bearings under zero measuring load.	Values (table 8) are valid for unmounted bearings under zero measuring load.	
Misalignment	≈ 20 to 30 minutes of arc		≈ 20 to 30 minutes of arc Initial misalignment ≤ 5°
	The above values apply only when the bearings rotate slowly. The permissible angular misalignment between the inner and outer ring depends on the size and internal design of the bearing, radial internal clearance in operation and the forces and moments acting on the bearing. As a result, only approximate values are listed here. Any misalignment increases bearing noise and reduces bearing service life.		
Stabilization	120 °C (250 °F)	150 °C (302 °F)	
	The rings, rolling elements and cages of SKF high temperature bearings and housings of SKF ball bearing units undergo the same heat stabilization process as the relevant standard bearing. As a result, for higher operating temperatures, a certain amount of dimensional change is to be expected. For additional information, contact the SKF application engineering service.		

Table 6

Tolerances of insert bearings for high temperature applications

Nominal diameter d, D		Bore diameter ¹⁾ Deviation		Outside diameter Deviation	
over	incl.	high	low	high	low
mm		µm		µm	
18	30	+18	0	–	–
30	50	+21	0	0	–10
50	80	+24	0	0	–10
80	120	+28	0	0	–15

¹⁾ Values in accordance with ISO 9628

Table 7

Radial internal clearance of deep groove ball bearings for high temperature applications

Bore diameter d		Radial internal clearance Multiples of C5	
over	incl.	min.	max.
mm		µm	
–	10	96	136
10	18	112	160
18	24	124	172
24	30	136	192
30	40	172	236
40	50	192	272
50	65	230	340
65	80	270	400
80	100	320	460
100	120	370	540

Table 8

Radial internal clearance of insert bearings for high temperature applications

Bore diameter d		Radial internal clearance	
over	incl.	min.	max.
mm		µm	
6	20	070	094
20	25	076	104
25	35	094	126
35	50	102	142
50	60	124	174
60	80	150	210

Deep groove ball bearings for high temperature applications

d 12 – 55 mm

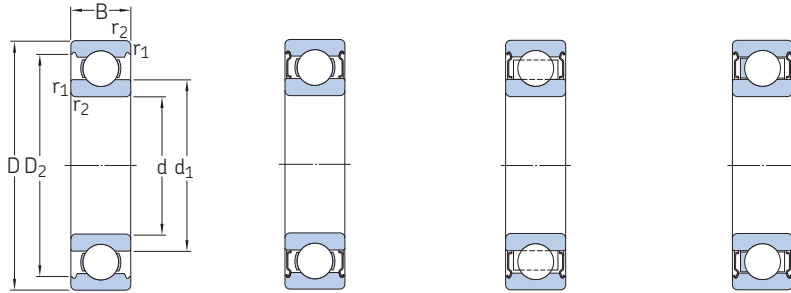

VA201¹⁾

2Z/VA201¹⁾

2Z/VA208

2Z/VA228

Principal dimensions			Basic static load ratings			Limiting speed	Limiting temperature		Mass	Designation	
d	D	B	d ₁ ≈	D ₂ ≈	r _{1,2} min	C ₀	T max.				
mm						kN	r/min	°C	°F	kg	–
12	32	10	18,4	27,4	0,6	3,1	200	250	480	0,037	6201/VA201
	32	10	18,4	27,4	0,6	3,1	200	250	480	0,039	6201-2Z/VA201
	32	10	18,4	27,4	0,6	3,1	400	350	660	0,039	6201-2Z/VA228
15	35	11	21,7	30,4	0,6	3,75	180	250	480	0,045	6202/VA201
	35	11	21,7	30,4	0,6	3,75	180	250	480	0,048	6202-2Z/VA201
	35	11	21,7	30,4	0,6	3,75	360	350	660	0,048	6202-2Z/VA228
	42	13	23,7	36,3	1	5,4	320	350	660	0,086	6302-2Z/VA228
17	35	10	23	31,2	0,3	3,25	170	250	480	0,038	6003/VA201
	35	10	23	31,2	0,3	3,25	170	250	480	0,041	6003-2Z/VA201
	35	10	23	31,2	0,3	3,25	170	350	660	0,041	6003-2Z/VA208
	40	12	24,5	35	0,6	4,75	160	250	480	0,065	6203/VA201
	40	12	24,5	35	0,6	4,75	160	250	480	0,068	6203-2Z/VA201
	40	12	24,5	35	0,6	4,75	310	350	660	0,068	6203-2Z/VA228
	47	14	26,5	39,6	1	6,55	140	250	480	0,11	6303/VA201
	47	14	26,5	39,6	1	6,55	140	250	480	0,13	6303-2Z/VA201
	47	14	26,5	39,6	1	6,55	280	350	660	0,12	6303-2Z/VA228
20	42	12	27,2	37,2	0,6	5	140	250	480	0,067	6004/VA201
	42	12	27,2	37,2	0,6	5	140	250	480	0,071	6004-2Z/VA201
	42	12	27,2	37,2	0,6	5	140	350	660	0,071	6004-2Z/VA208
	47	14	28,8	40,6	1	6,55	130	250	480	0,1	6204/VA201
	47	14	28,8	40,6	1	6,55	130	250	480	0,11	6204-2Z/VA201
	47	14	28,8	40,6	1	6,55	260	350	660	0,11	6204-2Z/VA228
	52	15	30,3	44,8	1,1	7,8	120	250	480	0,14	6304/VA201
	52	15	30,3	44,8	1,1	7,8	120	250	480	0,15	6304-2Z/VA201
	52	15	30,3	44,8	1,1	7,8	120	350	660	0,15	6304-2Z/VA208
	52	15	30,3	44,8	1,1	7,8	250	350	660	0,15	6304-2Z/VA228
25	47	12	32	42,2	0,6	6,55	120	250	480	0,078	6005/VA201
	47	12	32	42,2	0,6	6,55	120	250	480	0,083	6005-2Z/VA201
	47	12	32	42,2	0,6	6,55	120	350	660	0,083	6005-2Z/VA208
	52	15	34,3	46,3	1	7,8	120	250	480	0,13	6205/VA201
	52	15	34,3	46,3	1	7,8	120	250	480	0,13	6205-2Z/VA201
	52	15	34,3	46,3	1	7,8	120	350	660	0,13	6205-2Z/VA208
	52	15	34,3	46,3	1	7,8	230	350	660	0,13	6205-2Z/VA228
	62	17	36,6	52,7	1,1	11,6	100	250	480	0,23	6305/VA201
	62	17	36,6	52,7	1,1	11,6	100	250	480	0,23	6305-2Z/VA201
	62	17	36,6	52,7	1,1	11,6	100	350	660	0,23	6305-2Z/VA208
	62	17	36,6	52,7	1,1	11,6	200	350	660	0,23	6305-2Z/VA228

¹⁾ Running in required

Principal dimensions						Basic static load ratings	Limiting speed	Limiting temperature		Mass	Designation	
d	D	B	d ₁ ≈	D ₂ ≈	r _{1,2} min	C ₀		T max.				
mm						kN	r/min	°C	°F	kg	–	
30	55	13	38,2	49	1	8,3	100	350	660	0,12	6006-2Z/VA208	
	62	16	40,3	54,1	1	11,2	100	250	480	0,2	6206/VA201	
	62	16	40,3	54,1	1	11,2	100	250	480	0,21	6206-2Z/VA201	
	62	16	40,3	54,1	1	11,2	100	350	660	0,21	6206-2Z/VA208	
	62	16	40,3	54,1	1	11,2	190	350	660	0,21	6206-2Z/VA228	
	72	19	44,6	61,9	1,1	16	90	250	480	0,35	6306/VA201	
	72	19	44,6	61,9	1,1	16	90	250	480	0,35	6306-2Z/VA201	
	72	19	44,6	61,9	1,1	16	90	350	660	0,36	6306-2Z/VA208	
	72	19	44,6	61,9	1,1	16	170	350	660	0,36	6306-2Z/VA228	
	35	72	17	46,9	62,7	1,1	15,3	80	250	480	0,29	6207/VA201
		72	17	46,9	62,7	1,1	15,3	80	250	480	0,3	6207-2Z/VA201
		72	17	46,9	62,7	1,1	15,3	80	350	660	0,3	6207-2Z/VA208
72		17	46,9	62,7	1,1	15,3	160	350	660	0,3	6207-2Z/VA228	
80		21	49,5	69,2	1,5	19	80	250	480	0,46	6307/VA201	
80		21	49,5	69,2	1,5	19	80	250	480	0,47	6307-2Z/VA201	
80		21	49,5	69,2	1,5	19	80	350	660	0,48	6307-2Z/VA208	
40		68	15	49,2	61,1	1	11	80	350	660	0,2	6008-2Z/VA208
		80	18	52,6	69,8	1,1	19	70	250	480	0,37	6208/VA201
		80	18	52,6	69,8	1,1	19	70	250	480	0,38	6208-2Z/VA201
		80	18	52,6	69,8	1,1	19	70	350	660	0,38	6208-2Z/VA208
		80	18	52,6	69,8	1,1	19	150	350	660	0,38	6208-2Z/VA228
	90	23	56,1	77,7	1,5	24	70	250	480	0,63	6308/VA201	
	90	23	56,1	77,7	1,5	24	70	250	480	0,65	6308-2Z/VA201	
	90	23	56,1	77,7	1,5	24	70	350	660	0,65	6308-2Z/VA208	
	90	23	56,1	77,7	1,5	24	130	350	660	0,65	6308-2Z/VA228	
	45	85	19	57,6	75,2	1,1	21,6	70	250	480	0,42	6209/VA201
		85	19	57,6	75,2	1,1	21,6	70	250	480	0,43	6209-2Z/VA201
		85	19	57,6	75,2	1,1	21,6	70	350	660	0,43	6209-2Z/VA208
85		19	57,6	75,2	1,1	21,6	130	350	660	0,43	6209-2Z/VA228	
100		25	62,1	86,7	1,5	31,5	60	250	480	0,84	6309/VA201	
100		25	62,1	86,7	1,5	31,5	60	350	660	0,87	6309-2Z/VA208	
100		25	62,1	86,7	1,5	31,5	60	250	480	0,85	6309-2Z/VA201	
50		80	16	59,7	72,8	1	15,6	60	350	660	0,27	6010-2Z/VA208
		90	20	62,5	81,7	1,1	23,2	60	250	480	0,45	6210/VA201
		90	20	62,5	81,7	1,1	23,2	60	250	480	0,47	6210-2Z/VA201
		90	20	62,5	81,7	1,1	23,2	60	350	660	0,47	6210-2Z/VA208
		90	20	62,5	81,7	1,1	23,2	120	350	660	0,47	6210-2Z/VA228
	110	27	68,7	95,2	2	38	60	250	480	1,1	6310/VA201	
	110	27	68,7	95,2	2	38	60	250	480	1,1	6310-2Z/VA201	
	110	27	68,7	95,2	2	38	60	350	660	1,1	6310-2Z/VA208	
	110	27	68,7	95,2	2	38	110	350	660	1,1	6310-2Z/VA228	
	55	90	18	66,3	81,5	1,1	21,2	60	350	660	0,4	6011-2Z/VA208
		100	21	69	89,4	1,5	29	60	250	480	0,61	6211/VA201
		100	21	69	89,4	1,5	29	60	250	480	0,64	6211-2Z/VA201
100		21	69	89,4	1,5	29	60	350	660	0,64	6211-2Z/VA208	
100		21	69	89,4	1,5	29	110	350	660	0,64	6211-2Z/VA228	
120		29	75,3	104	2	45	50	250	480	1,35	6311/VA201	
120		29	75,3	104	2	45	50	250	480	1,4	6311-2Z/VA201	
120		29	75,3	104	2	45	50	350	660	1,4	6311-2Z/VA208	
120		29	75,3	104	2	45	100	350	660	1,4	6311-2Z/VA228	

Deep groove ball bearings for high temperature applications

d 60 – 120 mm

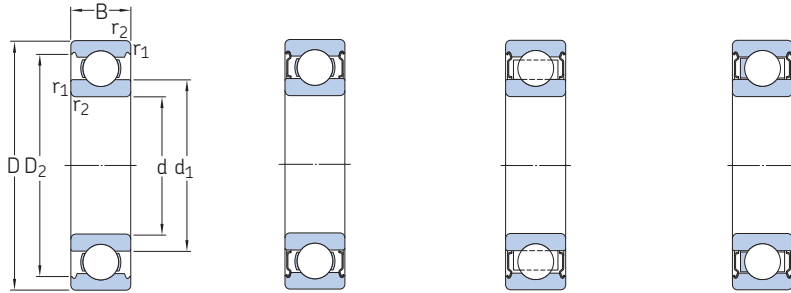

VA201¹⁾

ZZ/VA201¹⁾

ZZ/VA208

ZZ/VA228

Principal dimensions						Basic static load ratings	Limiting speed	Limiting temperature		Mass	Designation		
d	D	B	d ₁ ≈	D ₂ ≈	r _{1,2} min	C ₀		T max.					
mm						kN	r/min	°C	°F	kg	–		
60	110	22	75,5	98	1,5	36	50	250	480	0,78	6212/VA201		
	110	22	75,5	98	1,5	36	50	250	480	0,81	6212-ZZ/VA201		
	110	22	75,5	98	1,5	36	50	350	660	0,81	6212-ZZ/VA208		
	110	22	75,5	98	1,5	36	100	350	660	0,81	6212-ZZ/VA228		
	130	31	81,8	113	2,1	52	50	250	480	1,7	6312/VA201		
	130	31	81,8	113	2,1	52	50	250	480	1,8	6312-ZZ/VA201		
	130	31	81,8	113	2,1	52	50	350	660	1,8	6312-ZZ/VA208		
	130	31	81,8	113	2,1	52	90	350	660	1,8	6312-ZZ/VA228		
	65	120	23	83,3	106	1,5	40,5	50	250	480	1	6213/VA201	
		120	23	83,3	106	1,5	40,5	50	250	480	1,05	6213-ZZ/VA201	
		120	23	83,3	106	1,5	40,5	50	350	660	1,05	6213-ZZ/VA208	
		120	23	83,3	106	1,5	40,5	90	350	660	1,05	6213-ZZ/VA228	
140		33	88,3	122	2,1	60	40	250	480	2,1	6313/VA201		
140		33	88,3	122	2,1	60	40	250	480	2,2	6313-ZZ/VA201		
140		33	88,3	122	2,1	60	40	350	660	2,2	6313-ZZ/VA208		
140		33	88,3	122	2,1	60	80	350	660	2,2	6313-ZZ/VA228		
70		125	24	87	111	1,5	45	40	250	480	1,1	6214/VA201	
		125	24	87	111	1,5	45	40	250	480	1,15	6214-ZZ/VA201	
		125	24	87	111	1,5	45	40	350	660	1,15	6214-ZZ/VA208	
		125	24	87	111	1,5	45	90	350	660	1,15	6214-ZZ/VA228	
	150	35	94,9	130	2,1	68	40	250	480	2,55	6314/VA201		
	150	35	94,9	130	2,1	68	40	250	480	2,65	6314-ZZ/VA201		
	150	35	94,9	130	2,1	68	40	350	660	2,65	6314-ZZ/VA208		
	75	130	25	92	117	1,5	49	40	250	480	1,2	6215/VA201	
		130	25	92	117	1,5	49	40	250	480	1,25	6215-ZZ/VA201	
		130	25	92	117	1,5	49	40	350	660	1,25	6215-ZZ/VA208	
		130	25	92	117	1,5	49	80	350	660	1,25	6215-ZZ/VA228	
		160	37	101	139	2,1	76,5	40	250	480	3,05	6315/VA201	
160		37	101	139	2,1	76,5	40	250	480	3,15	6315-ZZ/VA201		
160		37	101	139	2,1	76,5	40	350	660	3,15	6315-ZZ/VA208		
80		140	26	101	127	2	55	40	250	480	1,55	6216-ZZ/VA201	
		140	26	101	127	2	55	40	350	660	1,55	6216-ZZ/VA208	
		170	39	108	147	2,1	86,5	30	350	660	3,75	6316-ZZ/VA208	
		85	150	28	106	135	2	64	40	250	480	1,8	6217/VA201
			150	28	106	135	2	64	40	250	480		6217-ZZ/VA201
	150		28	106	135	2	64	40	350	660	1,9	6217-ZZ/VA208	

¹⁾ Running in required

Principal dimensions						Basic static load ratings	Limiting speed	Limiting temperature		Mass	Designation
d	D	B	d ₁ ≈	D ₂ ≈	r _{1,2} min	C ₀		T max.			
mm						kN	r/min	°C	°F	kg	–
90	160	30	112	143	2	73,5	70	350	660	2,3	6218-2Z/VA228
95	170	32	118	152	2,1	81,5	30	250	480	2,6	6219/VA201
	170	32	118	152	2,1	81,5	30	250	480	2,7	6219-2Z/VA201
	170	32	118	152	2,1	81,5	60	350	660	2,7	6219-2Z/VA228
100	150	24	115	139	1,5	54	30	350	660	1,35	6020-2Z/VA208
	180	34	124	160	2,1	93	30	250	480	3,15	6220/VA201
	180	34	124	160	2,1	93	30	250	480	3,25	6220-2Z/VA201
	180	34	124	160	2,1	93	30	350	660	3,25	6220-2Z/VA208
	180	34	124	160	2,1	93	60	350	660	3,25	6220-2Z/VA228
110	170	28	129	156	2	73,5	30	350	660	2,05	6022-2Z/VA208
120	180	28	139	166	2	80	30	350	660	2,2	6024-2Z/VA208

Insert bearings for high temperature applications, metric shafts

d 20 – 60 mm

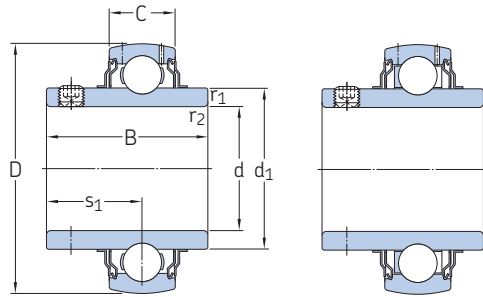

VA201¹⁾

VA228

Principal dimensions							Basic load ratings		Limiting speed	Limiting temperature		Mass	Designation
d	D	B	C	d ₁ ≈	s ₁	r _{1,2} min.	C	C ₀		T max.			
mm							kN		r/min	°C	°F	kg	–
20	47	31	14	28,2	18,3	0,6	12,7	6,55	130	250	480	0,15	YAR 204-2F/VA201
	47	31	14	28,2	18,3	0,6	12,7	6,55	260	350	660	0,15	YAR 204-2F/VA228
25	52	34,1	15	33,7	19,8	0,6	14	7,8	110	250	480	0,19	YAR 205-2F/VA201
	52	34,1	15	33,7	19,8	0,6	14	7,8	230	350	660	0,19	YAR 205-2F/VA228
30	62	38,1	18	39,7	22,2	0,6	19,5	11,2	90	250	480	0,31	YAR 206-2F/VA201
	62	38,1	18	39,7	22,2	0,6	19,5	11,2	190	350	660	0,31	YAR 206-2F/VA228
35	72	42,9	19	46,1	25,4	1	25,5	15,3	80	250	480	0,42	YAR 207-2F/VA201
	72	42,9	19	46,1	25,4	1	25,5	15,3	160	350	660	0,42	YAR 207-2F/VA228
40	80	49,2	21	51,8	30,2	1	30,7	19	70	250	480	0,61	YAR 208-2F/VA201
	80	49,2	21	51,8	30,2	1	30,7	19	150	350	660	0,61	YAR 208-2F/VA228
45	85	49,2	22	56,8	30,2	1	33,2	21,6	60	250	480	0,68	YAR 209-2F/VA201
	85	49,2	22	56,8	30,2	1	33,2	21,6	130	350	660	0,68	YAR 209-2F/VA228
50	90	51,6	22	62,5	32,6	1	35,1	23,2	60	250	480	0,77	YAR 210-2F/VA201
	90	51,6	22	62,5	32,6	1	35,1	23,2	120	350	660	0,77	YAR 210-2F/VA228
55	100	55,6	25	69	33,4	1	43,6	29	50	250	480	1,05	YAR 211-2F/VA201
	100	55,6	25	69	33,4	1	43,6	29	110	350	660	1,05	YAR 211-2F/VA228
60	110	65,1	26	75,6	39,7	1,5	52,7	36	50	250	480	1,45	YAR 212-2F/VA201
	110	65,1	26	75,6	39,7	1,5	52,7	36	100	350	660	1,4	YAR 212-2F/VA228

¹⁾ Running in required
Not intended for relubrication

Insert bearings for high temperature applications, inch shafts

d $\frac{3}{4}$ – $2\frac{7}{16}$ in.

19,05 – 61,913 mm

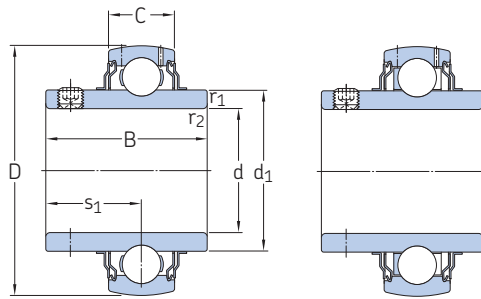

VA201¹⁾

VA228

Principal dimensions							Basic load ratings		Limiting speed	Limiting temperature		Mass	Designation
d	D	B	C	d ₁	s ₁	r _{1,2} min.	C	C ₀		T max.		kg	–
in./mm							kN		r/min	°C	°F		
$\frac{3}{4}$	47	31	14	28,2	21,4	0,6	12,7	6,55	130	250	480	0,16	YAR 204-012-2F/VA201
19,05	47	31	14	28,2	21,4	0,6	12,7	6,55	260	350	660	0,16	YAR 204-012-2F/VA228
1	52	34,1	15	33,74	19,8	0,6	14	7,8	110	250	480	0,19	YAR 205-100-2F/VA201
25,4	52	34,1	15	33,74	19,8	0,6	14	7,8	230	350	660	0,19	YAR 205-100-2F/VA228
$1\frac{3}{16}$	62	38,1	18	39,7	18,2	0,6	19,5	11,2	90	250	480	0,31	YAR 206-103-2F/VA201
30,163	62	38,1	18	39,7	18,2	0,6	19,5	11,2	190	350	660	0,31	YAR 206-103-2F/VA228
$1\frac{1}{4}$	72	42,9	19	46,1	16,6	1	25,5	15,3	80	250	480	0,48	YAR 207-104-2F/VA201
31,75	72	42,9	19	46,1	16,6	1	25,5	15,3	160	350	660	0,48	YAR 207-104-2F/VA228
$1\frac{3}{8}$	72	42,9	19	46,1	16,6	1	25,5	15,3	80	250	480	0,43	YAR 207-106-2F/VA201
34,925	72	42,9	19	46,1	16,6	1	25,5	15,3	160	350	660	0,42	YAR 207-106-2F/VA228
$1\frac{7}{16}$	72	42,9	19	46,1	16,6	1	25,5	15,3	80	250	480	0,4	YAR 207-107-2F/VA201
36,513	72	42,9	19	46,1	16,6	1	25,5	15,3	160	350	660	0,39	YAR 207-107-2F/VA228
$1\frac{1}{2}$	80	49,2	21	51,8	15,1	1	30,7	19	70	250	480	0,66	YAR 208-108-2F/VA201
38,1	80	49,2	21	51,8	15,1	1	30,7	19	150	350	660	0,65	YAR 208-108-2F/VA228
$1\frac{11}{16}$	85	49,2	22	56,8	15,1	1	33,2	21,6	60	250	480	0,74	YAR 209-111-2F/VA201
42,863	85	49,2	22	56,8	15,1	1	33,2	21,6	130	350	660	0,73	YAR 209-111-2F/VA228
$1\frac{3}{4}$	85	49,2	22	56,8	15,1	1	33,2	21,6	60	250	480	0,69	YAR 209-112-2F/VA201
44,45	85	49,2	22	56,8	15,1	1	33,2	21,6	130	350	660	0,69	YAR 209-112-2F/VA228
$1\frac{15}{16}$	90	51,6	22	62,51	15,1	1	35,1	23,2	60	250	480	0,8	YAR 210-115-2F/VA201
49,213	90	51,6	22	62,51	15,1	1	35,1	23,2	120	350	660	0,79	YAR 210-115-2F/VA228
2	100	55,6	25	69,06	11,9	1	43,6	29	50	250	480	1,2	YAR 211-200-2F/VA201
50,8	100	55,6	25	69,06	11,9	1	43,6	29	110	350	660	1,2	YAR 211-200-2F/VA228
$2\frac{3}{16}$	100	55,6	25	69,06	11,9	1	43,6	29	50	250	480	1,05	YAR 211-203-2F/VA201
55,563	100	55,6	25	69,06	11,9	1	43,6	29	110	350	660	1	YAR 211-203-2F/VA228
$2\frac{7}{16}$	110	65,1	26	75,64	8,7	1,5	52,7	36	50	250	480	1,35	YAR 212-207-2F/VA201
61,913	110	65,1	26	75,64	8,7	1,5	52,7	36	100	350	660	1,35	YAR 212-207-2F/VA228

¹⁾ Running in required
Not intended for relubrication

Ball bearing plummer (pillow) block units for high temperature applications, metric shafts, ISO

d 20 – 60 mm

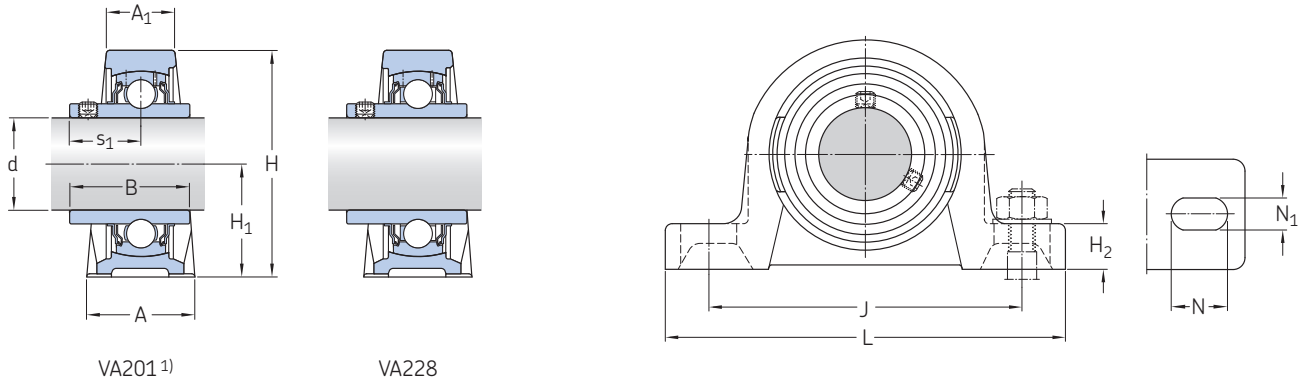

Principal dimensions			Basic load ratings		Limiting speed	Limiting temperature		Designations Unit	Bearing
d	H ₁	J	C	C ₀		T max.	°C		
mm			kN		r/min	°C	°F	–	
20	33,3	97	12,7	6,55	130	250	480	SY 20 TF/VA201	YAR 204-2F/VA201
	33,3	97	12,7	6,55	260	350	660	SY 20 TF/VA228	YAR 204-2F/VA228
25	36,5	102	14	7,8	110	250	480	SY 25 TF/VA201	YAR 205-2F/VA201
	36,5	102	14	7,8	230	350	660	SY 25 TF/VA228	YAR 205-2F/VA228
30	42,9	117,5	19,5	11,2	90	250	480	SY 30 TF/VA201	YAR 206-2F/VA201
	42,9	117,5	19,5	11,2	190	350	660	SY 30 TF/VA228	YAR 206-2F/VA228
35	47,6	126	25,5	15,3	80	250	480	SY 35 TF/VA201	YAR 207-2F/VA201
	47,6	126	25,5	15,3	160	350	660	SY 35 TF/VA228	YAR 207-2F/VA228
40	49,2	135,5	30,7	19	70	250	480	SY 40 TF/VA201	YAR 208-2F/VA201
	49,2	135,5	30,7	19	150	350	660	SY 40 TF/VA228	YAR 208-2F/VA228
45	54	143,5	33,2	21,6	60	250	480	SY 45 TF/VA201	YAR 209-2F/VA201
	54	143,5	33,2	21,6	130	350	660	SY 45 TF/VA228	YAR 209-2F/VA228
50	57,2	157	35,1	23,2	60	250	480	SY 50 TF/VA201	YAR 210-2F/VA201
	57,2	157	35,1	23,2	120	350	660	SY 50 TF/VA228	YAR 210-2F/VA228
55	63,5	171,5	43,6	29	50	250	480	SY 55 TF/VA201	YAR 211-2F/VA201
	63,5	171,5	43,6	29	110	350	660	SY 55 TF/VA228	YAR 211-2F/VA228
60	69,9	171,5	52,7	36	50	250	480	SY 60 TF/VA201	YAR 212-2F/VA201
	69,9	171,5	52,7	36	100	350	660	SY 60 TF/VA228	YAR 212-2F/VA228

¹⁾ Running in required
Not intended for relubrication

Dimensions										Mass
d	A	A ₁	B	H	H ₂	L	N	N ₁	s ₁	
mm										kg
20	32	21	31	64,5	14	127	20,5	11,5	18,3	0,56
	32	21	31	64,5	14	127	20,5	11,5	18,3	0,56
25	36	22	34,1	70	16	130	19,5	11,5	19,8	0,73
	36	22	34,1	70	16	130	19,5	11,5	19,8	0,73
30	40	25	38,1	82	17	152	23,5	14	22,2	1,05
	40	25	38,1	82	17	152	23,5	14	22,2	1,05
35	45	27	42,9	93	19	160	21	14	25,4	1,45
	45	27	42,9	93	19	160	21	14	25,4	1,45
40	48	30	49,2	99	19	175	24,5	14	30,2	1,8
	48	30	49,2	99	19	175	24,5	14	30,2	1,8
45	48	32	49,2	107	21	187	22,5	14	30,2	2,2
	48	32	49,2	107	21	187	22,5	14	30,2	2,2
50	54	34	51,6	114	22	203	26	18	32,6	2,65
	54	34	51,6	114	22	203	26	18	32,6	2,65
55	60	40	55,6	126	24	219	27,5	18	33,4	3,45
	60	40	55,6	126	24	219	27,5	18	33,4	3,4
60	60	42	65,1	126	24	219	27,5	18	39,7	4,45
	60	42	65,1	126	24	219	27,5	18	39,7	4,45

Ball bearing plummer (pillow) block units for high temperature applications, inch shafts, ISO

d $\frac{3}{4}$ – 2 $\frac{7}{16}$ in.

19,05 – 61,913 mm

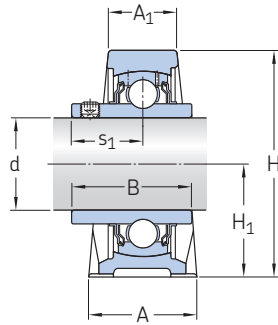

VA201¹⁾

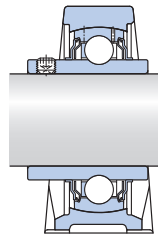

VA228

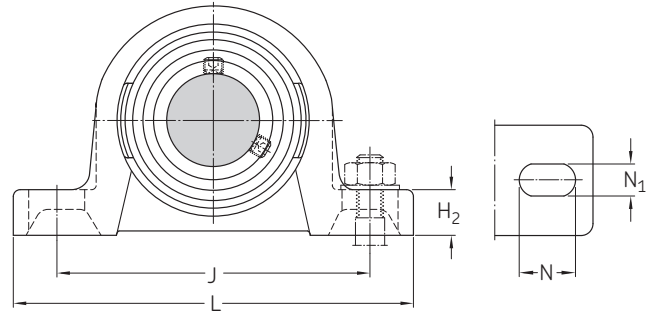

Principal dimensions			Basic load ratings		Limiting speed	Limiting temperature		Designations Unit	Bearing
d	H ₁	J	C	C ₀		T max.	°C		
in./mm			kN		r/min	°C	°F	–	
$\frac{3}{4}$	33,3	97	12,7	6,55	130	250	480	SY $\frac{3}{4}$ TF/VA201	YAR 204-012-2F/VA201
19,05	33,3	97	12,7	6,55	260	350	660	SY $\frac{3}{4}$ TF/VA228	YAR 204-012-2F/VA228
1	36,5	102	14	7,8	110	250	480	SY 1. TF/VA201	YAR 205-100-2F/VA201
25,4	36,5	102	14	7,8	230	350	660	SY 1. TF/VA228	YAR 205-100-2F/VA228
$1\frac{3}{16}$	42,9	117,5	19,5	11,2	90	250	480	SY 1.3/16 TF/VA201	YAR 206-103-2F/VA201
30,163	42,9	117,5	19,5	11,2	190	350	660	SY 1.3/16 TF/VA228	YAR 206-103-2F/VA228
$1\frac{1}{4}$	47,6	126	25,5	15,3	80	250	480	SY 1.1/4 TF/VA201	YAR 207-104-2F/VA201
31,75	47,6	126	25,5	15,3	160	350	660	SY 1.1/4 TF/VA228	YAR 207-104-2F/VA228
$1\frac{3}{8}$	47,6	126	25,5	15,3	80	250	480	SY 1.3/8 TF/VA201	YAR 207-106-2F/VA201
34,925	47,6	126	25,5	15,3	160	350	660	SY 1.3/8 TF/VA228	YAR 207-106-2F/VA228
$1\frac{7}{16}$	47,6	126	25,5	15,3	80	250	480	SY 1.7/16 TF/VA201	YAR 207-107-2F/VA201
36,513	47,6	126	25,5	15,3	160	350	660	SY 1.7/16 TF/VA228	YAR 207-107-2F/VA228
$1\frac{1}{2}$	49,2	135,5	30,7	19	70	250	480	SY 1.1/2 TF/VA201	YAR 208-108-2F/VA201
38,1	49,2	135,5	30,7	19	150	350	660	SY 1.1/2 TF/VA228	YAR 208-108-2F/VA228
$1\frac{11}{16}$	54	143,5	33,2	21,6	60	250	480	SY 1.11/16 TF/VA201	YAR 209-111-2F/VA201
42,863	54	143,5	33,2	21,6	130	350	660	SY 1.11/16 TF/VA228	YAR 209-111-2F/VA228
$1\frac{3}{4}$	54	143,5	33,2	21,6	60	250	480	SY 1.3/4 TF/VA201	YAR 209-112-2F/VA201
44,45	54	143,5	33,2	21,6	130	350	660	SY 1.3/4 TF/VA228	YAR 209-112-2F/VA228
$1\frac{15}{16}$	57,2	157	35,1	23,2	60	250	480	SY 1.15/16 TF/VA201	YAR 210-115-2F/VA201
49,213	57,2	157	35,1	23,2	120	350	660	SY 1.15/16 TF/VA228	YAR 210-115-2F/VA228
2	63,5	171,5	43,6	29	50	250	480	SY 2. TF/VA201	YAR 211-200-2F/VA201
50,8	63,5	171,5	43,6	29	110	350	660	SY 2. TF/VA228	YAR 211-200-2F/VA228
$2\frac{3}{16}$	63,5	171,5	43,6	29	50	250	480	SY 2.3/16 TF/VA201	YAR 211-203-2F/VA201
55,563	63,5	171,5	43,6	29	110	350	660	SY 2.3/16 TF/VA228	YAR 211-203-2F/VA228
$2\frac{7}{16}$	69,9	171,5	52,7	36	50	250	480	SY 2.7/16 TF/VA201	YAR 212-207-2F/VA201
61,913	69,9	171,5	52,7	36	100	350	660	SY 2.7/16 TF/VA228	YAR 212-207-2F/VA228

¹⁾ Running in required
Not intended for relubrication

Dimensions										Mass
d	A	A ₁	B	H	H ₂	L	N	N ₁	s ₁	
in./mm										kg
$\frac{3}{4}$	32	21	31	64,5	14	127	20,5	11,5	18,3	0,57
19,05	32	21	31	64,5	14	127	20,5	11,5	18,3	0,57
1	36	22	34,1	70	16	130	19,5	11,5	19,8	0,72
25,4	36	22	34,1	70	16	130	19,5	11,5	19,8	0,73
$1\frac{3}{16}$	40	25	38,1	82	17	152	23,5	14	22,2	0,81
30,163	40	25	38,1	82	17	152	23,5	14	22,2	1,05
$1\frac{1}{4}$	45	27	42,9	93	19	160	21	14	25,4	1,5
31,75	45	27	42,9	93	19	160	21	14	25,4	1,5
$1\frac{3}{8}$	45	27	42,9	93	19	160	21	14	25,4	1,45
34,925	45	27	42,9	93	19	160	21	14	25,4	1,45
$1\frac{7}{16}$	45	27	42,9	93	19	160	21	14	25,4	1,45
36,513	45	27	42,9	93	19	160	21	14	25,4	1,45
$1\frac{1}{2}$	48	30	49,2	99	19	175	24,5	14	30,2	1,85
38,1	48	30	49,2	99	19	175	24,5	14	30,2	1,85
$1\frac{11}{16}$	48	32	49,2	107	21	187	22,5	14	30,2	2,2
42,863	48	32	49,2	107	21	187	22,5	14	30,2	2,25
$1\frac{3}{4}$	48	32	49,2	107	21	187	22,5	14	30,2	2,2
44,45	48	32	49,2	107	21	187	22,5	14	30,2	2,2
$1\frac{15}{16}$	54	34	51,6	114	22	203	26	18	32,6	2,7
49,213	54	34	51,6	114	22	203	26	18	32,6	2,7
2	60	40	55,6	126	24	219	27,5	18	33,4	3,6
50,8	60	40	55,6	126	24	219	27,5	18	33,4	3,55
$2\frac{3}{16}$	60	40	55,6	126	24	219	27,5	18	33,4	3,4
55,563	60	40	55,6	126	24	219	27,5	18	33,4	3,4
$2\frac{7}{16}$	60	42	65,1	126	24	219	27,5	18	39,7	4,35
61,913	60	42	65,1	126	24	219	27,5	18	39,7	4,35

Ball bearing square flanged units for high temperature applications, metric shafts, ISO

d 20 – 60 mm

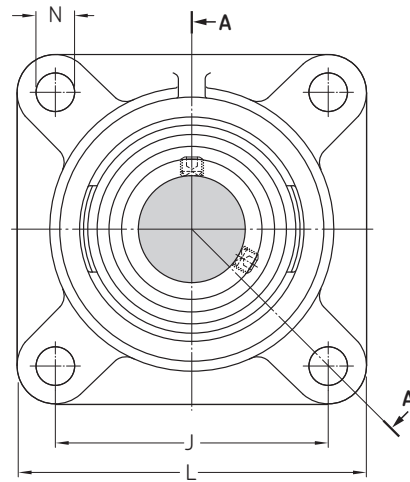
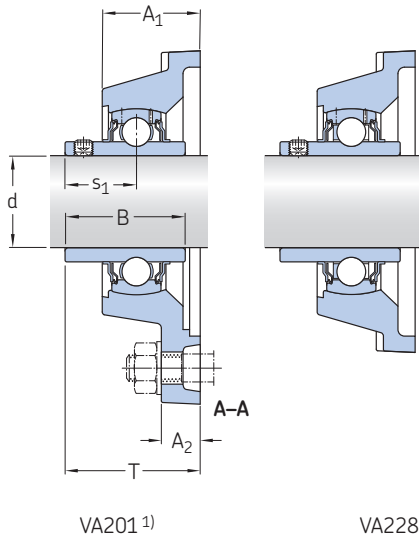

Principal dimensions		Basic load ratings		Limiting speed	Limiting temperature		Designations Unit	Bearing
d	J	C	C ₀		T max.			
mm		kN		r/min	°C	°F	–	
20	63,5	12,7	6,55	130	250	480	FY 20 TF/VA201	YAR 204-2F/VA201
	63,5	12,7	6,55	260	350	660	FY 20 TF/VA228	YAR 204-2F/VA228
25	70	14	7,8	110	250	480	FY 25 TF/VA201	YAR 205-2F/VA201
	70	14	7,8	230	350	660	FY 25 TF/VA228	YAR 205-2F/VA228
30	82,5	19,5	11,2	90	250	480	FY 30 TF/VA201	YAR 206-2F/VA201
	82,5	19,5	11,2	190	350	660	FY 30 TF/VA228	YAR 206-2F/VA228
35	92	25,5	15,3	80	250	480	FY 35 TF/VA201	YAR 207-2F/VA201
	92	25,5	15,3	160	350	660	FY 35 TF/VA228	YAR 207-2F/VA228
40	101,5	30,7	19	70	250	480	FY 40 TF/VA201	YAR 208-2F/VA201
	101,5	30,7	19	150	350	660	FY 40 TF/VA228	YAR 208-2F/VA228
45	105	33,2	21,6	60	250	480	FY 45 TF/VA201	YAR 209-2F/VA201
	105	33,2	21,6	130	350	660	FY 45 TF/VA228	YAR 209-2F/VA228
50	111	35,1	23,2	60	250	480	FY 50 TF/VA201	YAR 210-2F/VA201
	111	35,1	23,2	120	350	660	FY 50 TF/VA228	YAR 210-2F/VA228
55	130	43,6	29	50	250	480	FY 55 TF/VA201	YAR 211-2F/VA201
	130	43,6	29	110	350	660	FY 55 TF/VA228	YAR 211-2F/VA228
60	143	52,7	36	50	250	480	FY 60 TF/VA201	YAR 212-2F/VA201
	143	52,7	36	100	350	660	FY 60 TF/VA228	YAR 212-2F/VA228

¹⁾ Running in required
Not intended for relubrication

Dimensions								Mass
d	A ₁	A ₂	B	L	N	s ₁	T	
mm								kg
20	29,5	11	31	86	11,5	18,3	37,3	0,54
	29,5	11	31	86	11,5	18,3	37,3	0,55
25	30	12	34,1	95	11,5	19,8	38,8	0,72
	30	12	34,1	95	11,5	19,8	38,8	0,72
30	32,5	13	38,1	108	11,5	22,2	42,2	1,05
	32,5	13	38,1	108	11,5	22,2	42,2	1,05
35	34,5	13	42,9	118	14	25,4	46,4	1,3
	34,5	13	42,9	118	14	25,4	46,4	1,3
40	38,5	14	49,2	130	14	30,2	54,2	1,8
	38,5	14	49,2	130	14	30,2	54,2	1,8
45	39	14	49,2	137	16	30,2	54,2	2
	39	14	49,2	137	16	30,2	54,2	2
50	43	15	51,6	143	18	32,6	60,6	2,3
	43	15	51,6	143	18	32,6	60,6	2,3
55	47,5	16	55,6	162	18	33,4	64,4	3,35
	47,5	16	55,6	162	18	33,4	64,4	3,35
60	52	17	65,1	175	18	39,7	73,7	4
	52	17	65,1	175	18	39,7	73,7	4

Ball bearing square flanged units for high temperature applications, inch shafts, ISO

d 3/4 – 2 7/16 in.

19,05 – 61,913 mm

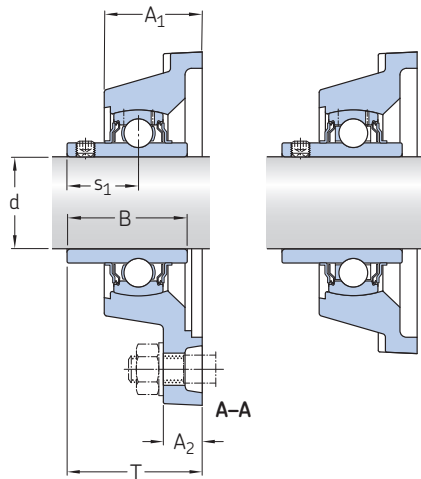

VA201¹⁾

VA228

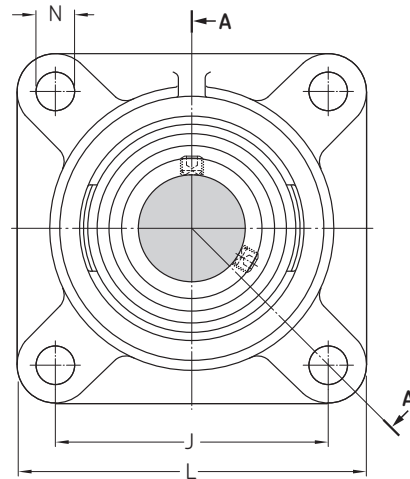

Principal dimensions		Basic load ratings dynamic static		Limiting speed	Limiting temperature		Designations Unit	Bearing
d	J	C	C ₀		T max.			
in./mm		kN		r/min	°C	°F	–	
3/4	63,5	12,7	6,55	130	250	480	FY 3/4 TF/VA201	YAR 204-012-2F/VA201
19,05	63,5	12,7	6,55	260	350	660	FY 3/4 TF/VA228	YAR 204-012-2F/VA228
1	70	14	7,8	110	250	480	FY 1. TF/VA201	YAR 205-100-2F/VA201
25,4	70	14	7,8	230	350	660	FY 1. TF/VA228	YAR 205-100-2F/VA228
1 3/16	82,5	19,5	11,2	90	250	480	FY 1.3/16 TF/VA201	YAR 206-103-2F/VA201
30,163	82,5	19,5	11,2	190	350	660	FY 1.3/16 TF/VA228	YAR 206-103-2F/VA228
1 1/4	92	25,5	15,3	80	250	480	FY 1.1/4 TF/VA201	YAR 207-104-2F/VA201
31,75	92	25,5	15,3	160	350	660	FY 1.1/4 TF/VA228	YAR 207-104-2F/VA228
1 7/16	92	25,5	15,3	80	250	480	FY 1.7/16 TF/VA201	YAR 207-107-2F/VA201
36,513	92	25,5	15,3	160	350	660	FY 1.7/16 TF/VA228	YAR 207-107-2F/VA228
1 1/2	101,5	30,7	19	70	250	480	FY 1.1/2 TF/VA201	YAR 208-108-2F/VA201
38,1	101,5	30,7	19	150	350	660	FY 1.1/2 TF/VA228	YAR 208-108-2F/VA228
1 11/16	105	33,2	21,6	60	250	480	FY 1.11/16 TF/VA201	YAR 209-111-2F/VA201
42,863	105	33,2	21,6	130	350	660	FY 1.11/16 TF/VA228	YAR 209-111-2F/VA228
1 3/4	105	33,2	21,6	60	250	480	FY 1.3/4 TF/VA201	YAR 209-112-2F/VA201
44,45	105	33,2	21,6	130	350	660	FY 1.3/4 TF/VA228	YAR 209-112-2F/VA228
1 15/16	111	35,1	23,2	60	250	480	FY 1.15/16 TF/VA201	YAR 210-115-2F/VA201
49,213	111	35,1	23,2	120	350	660	FY 1.15/16 TF/VA228	YAR 210-115-2F/VA228
2	130	43,6	29	50	250	480	FY 2. TF/VA201	YAR 211-200-2F/VA201
50,8	130	43,6	29	110	350	660	FY 2. TF/VA228	YAR 211-200-2F/VA228
2 3/16	130	43,6	29	50	250	480	FY 2.3/16 TF/VA201	YAR 211-203-2F/VA201
55,563	130	43,6	29	110	350	660	FY 2.3/16 TF/VA228	YAR 211-203-2F/VA228
2 7/16	143	52,7	36	50	250	480	FY 2.7/16 TF/VA201	YAR 212-207-2F/VA201
61,913	143	52,7	36	100	350	660	FY 2.7/16 TF/VA228	YAR 212-207-2F/VA228

¹⁾ Running in required
Not intended for relubrication

Dimensions								Mass
d	A ₁	A ₂	B	L	N	s ₁	T	
in./mm								kg
3/4	29,5	11	31	86	11,5	18,3	37,3	0,55
19,05	29,5	11	31	86	11,5	18,3	37,3	0,55
1	30	12	34,1	95	11,5	19,8	38,8	0,72
25,4	30	12	34,1	95	11,5	19,8	38,8	0,72
1^{3/16}	32,5	13	38,1	108	11,5	22,2	42,2	0,8
30,163	32,5	13	38,1	108	11,5	22,2	42,2	1,05
1^{1/4}	34,5	13	42,9	118	14	25,4	46,4	1,35
31,75	34,5	13	42,9	118	14	25,4	46,4	1,35
1^{7/16}	34,5	13	42,9	118	14	25,4	46,4	1,3
36,513	34,5	13	42,9	118	14	25,4	46,4	1,35
1^{1/2}	38,5	14	49,2	130	14	30,2	54,2	1,85
38,1	38,5	14	49,2	130	14	30,2	54,2	1,85
1^{11/16}	39	14	49,2	137	16	30,2	54,2	2,05
42,863	39	14	49,2	137	16	30,2	54,2	2,05
1^{3/4}	39	14	49,2	137	16	30,2	54,2	2
44,45	39	14	49,2	137	16	30,2	54,2	2
1^{15/16}	43	15	51,6	143	18	32,6	60,6	2,35
49,213	43	15	51,6	143	18	32,6	60,6	2,35
2	47,5	16	55,6	162	18	33,4	64,4	3,5
50,8	47,5	16	55,6	162	18	33,4	64,4	3,5
2^{3/16}	47,5	16	55,6	162	18	33,4	64,4	3,3
55,563	47,5	16	55,6	162	18	33,4	64,4	3,35
2^{7/16}	52	17	65,1	175	18	39,7	73,7	3,9
61,913	52	17	65,1	175	18	39,7	73,7	3,9

Ball bearing oval flanged units for high temperature applications, metric shafts, ISO

d 20 – 55 mm

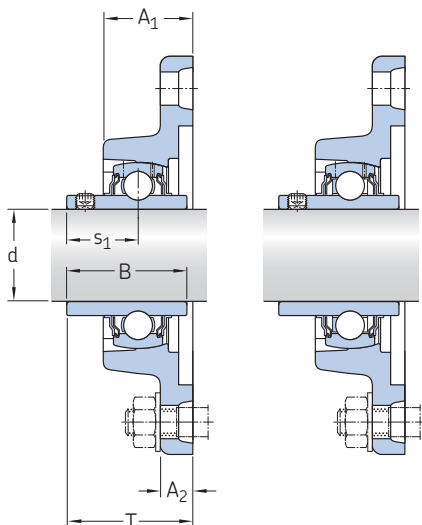

VA201¹⁾

VA228

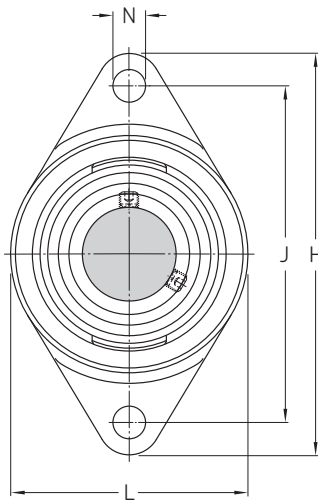

Principal dimensions		Basic load ratings		Limiting speed	Limiting temperature		Designations Unit	Bearing
d	J	C	C ₀		T max.	°F		
mm		kN		r/min	°C	°F	–	
20	90	12,7	6,55	130	250	480	FYTB 20 TF/VA201	YAR 204-2F/VA201
	90	12,7	6,55	260	350	660	FYTB 20 TF/VA228	YAR 204-2F/VA228
25	99	14	7,8	110	250	480	FYTB 25 TF/VA201	YAR 205-2F/VA201
	99	14	7,8	230	350	660	FYTB 25 TF/VA228	YAR 205-2F/VA228
30	116,5	19,5	11,2	90	250	480	FYTB 30 TF/VA201	YAR 206-2F/VA201
	116,5	19,5	11,2	190	350	660	FYTB 30 TF/VA228	YAR 206-2F/VA228
35	130	25,5	15,3	80	250	480	FYTB 35 TF/VA201	YAR 207-2F/VA201
	130	25,5	15,3	160	350	660	FYTB 35 TF/VA228	YAR 207-2F/VA228
40	143,5	30,7	19	70	250	480	FYTB 40 TF/VA201	YAR 208-2F/VA201
	143,5	30,7	19	150	350	660	FYTB 40 TF/VA228	YAR 208-2F/VA228
45	148,5	33,2	21,6	60	250	480	FYTB 45 TF/VA201	YAR 209-2F/VA201
	148,5	33,2	21,6	130	350	660	FYTB 45 TF/VA228	YAR 209-2F/VA228
50	157	35,1	23,2	60	250	480	FYTB 50 TF/VA201	YAR 210-2F/VA201
	157	35,1	23,2	120	350	660	FYTB 50 TF/VA228	YAR 210-2F/VA228
55	184	43,6	29	50	250	480	FYTB 55 TF/VA201	YAR 211-2F/VA201
	184	43,6	29	110	350	660	FYTB 55 TF/VA228	YAR 211-2F/VA228

¹⁾ Running in required
Not intended for relubrication

Dimensions									Mass
d	A ₁	A ₂	B	H	L	N	s ₁	T	
mm									kg
20	29,5	11	31	112	60,5	11,5	18,3	37,3	0,45
	29,5	11	31	112	60,5	11,5	18,3	37,3	0,45
25	30	12	34,1	124	70	11,5	19,8	38,8	0,59
	30	12	34,1	124	70	11,5	19,8	38,8	0,59
30	32,5	13	38,1	141,5	83	11,5	22,2	42,2	0,88
	32,5	13	38,1	141,5	83	11,5	22,2	42,2	0,88
35	34,5	13	42,9	156	96	14	25,4	46,4	1,2
	34,5	13	42,9	156	96	14	25,4	46,4	1,2
40	38,5	14	49,2	171,5	102	14	30,2	54,2	1,6
	38,5	14	49,2	171,5	102	14	30,2	54,2	1,6
45	39	14	49,2	178,5	111	16	30,2	54,2	1,8
	39	14	49,2	178,5	111	16	30,2	54,2	1,8
50	43	15	51,6	189	116	18	32,6	60,6	2,1
	43	15	51,6	189	116	18	32,6	60,6	2,1
55	47	16	55,6	216	127	18	33,4	64,4	2,75
	47	16	55,6	216	127	18	33,4	64,4	2,75

Ball bearing oval flanged units for high temperature applications, inch shafts, ISO

d 3/4 – 2 in.

19,05 – 50,8 mm

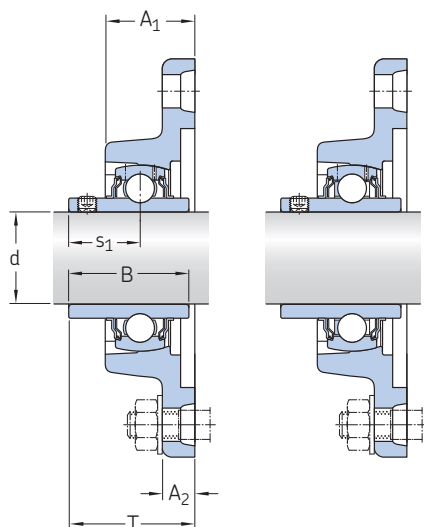

VA201¹⁾

VA228

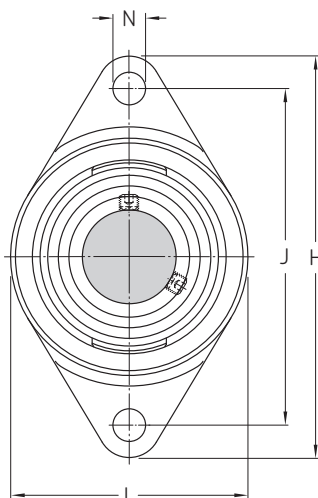

Principal dimensions		Basic load ratings		Limiting speed	Limiting temperature		Designations Unit	Bearing
d	J	C	C ₀		T max.	°C		
in./mm		kN		r/min	°C	°F	–	
3/4 19,05	90	12,7	6,55	130	250	480	FYTB 3/4 TF/VA201	YAR 204-012-2F/VA201
	90	12,7	6,55	260	350	660	FYTB 3/4 TF/VA228	YAR 204-012-2F/VA228
1 25,4	99	14	7,8	110	250	480	FYTB 1. TF/VA201	YAR 205-100-2F/VA201
	99	14	7,8	230	350	660	FYTB 1. TF/VA228	YAR 205-100-2F/VA228
1 1/4 31,75	130	25,5	15,3	80	250	480	FYTB 1.1/4 TF/VA201	YAR 207-104-2F/VA201
	130	25,5	15,3	160	350	660	FYTB 1.1/4 TF/VA228	YAR 207-104-2F/VA228
1 3/8 34,925	130	25,5	15,3	80	250	480	FYTB 1.3/8 TF/VA201	YAR 207-106-2F/VA201
	130	25,5	15,3	160	350	660	FYTB 1.3/8 TF/VA228	YAR 207-106-2F/VA228
1 1/2 38,1	143,5	30,7	19	70	250	480	FYTB 1.1/2 TF/VA201	YAR 208-108-2F/VA201
	143,5	30,7	19	150	350	660	FYTB 1.1/2 TF/VA228	YAR 208-108-2F/VA228
1 11/16 42,863	148,5	33,2	21,6	60	250	480	FYTB 1.11/16 TF/VA201	YAR 209-111-2F/VA201
	148,5	33,2	21,6	130	350	660	FYTB 1.11/16 TF/VA228	YAR 209-111-2F/VA228
1 3/4 44,45	148,5	33,2	21,6	60	250	480	FYTB 1.3/4 TF/VA201	YAR 209-112-2F/VA201
	148,5	33,2	21,6	130	350	660	FYTB 1.3/4 TF/VA228	YAR 209-112-2F/VA228
1 15/16 49,213	157	35,1	23,2	60	250	480	FYTB 1.15/16 TF/VA201	YAR 210-115-2F/VA201
	157	35,1	23,2	120	350	660	FYTB 1.15/16 TF/VA228	YAR 210-115-2F/VA228
2 50,8	184	43,6	29	50	250	480	FYTB 2. TF/VA201	YAR 211-200-2F/VA201
	184	43,6	29	110	350	660	FYTB 2. TF/VA228	YAR 211-200-2F/VA228

¹⁾ Running in required
Not intended for relubrication

Dimensions									Mass
d	A ₁	A ₂	B	H	L	N	s ₁	T	
in./mm									kg
$\frac{3}{4}$	29,5	11	31	112	60,5	11,5	18,3	37,3	0,46
19,05	29,5	11	31	112	60,5	11,5	18,3	37,3	0,45
1	30	12	34,1	124	70	11,5	19,8	38,8	0,59
25,4	30	12	34,1	124	70	11,5	19,8	38,8	0,59
$1\frac{1}{4}$	34,5	13	42,9	156	96	14	25,4	46,4	1,25
31,75	34,5	13	42,9	156	96	14	25,4	46,4	1,25
$1\frac{3}{8}$	34,5	13	42,9	156	96	14	25,4	46,4	1,2
34,925	34,5	13	42,9	156	96	14	25,4	46,4	1,2
$1\frac{1}{2}$	38,5	14	49,2	171,5	102	14	30,2	54,2	1,65
38,1	38,5	14	49,2	171,5	102	14	30,2	54,2	1,65
$1\frac{11}{16}$	39	14	49,2	178,5	111	16	30,2	54,2	1,85
42,863	39	14	49,2	178,5	111	16	30,2	54,2	1,85
$1\frac{3}{4}$	39	14	49,2	178,5	111	16	30,2	54,2	1,8
44,45	39	14	49,2	178,5	111	16	30,2	54,2	1,8
$1\frac{15}{16}$	43	15	51,6	189	116	18	32,6	60,6	2,1
49,213	43	15	51,6	189	116	18	32,6	60,6	2,1
2	47	16	55,6	216	127	18	33,4	64,4	2,9
50,8	47	16	55,6	216	127	18	33,4	64,4	2,9

[skf.com](https://www.skf.com)

® SKF is a registered trademark of the SKF Group.

NILOS-Ring is a registered trademark of Ziller GmbH & Co. KG.

© SKF Group 2019

The contents of this publication are the copyright of the publisher and may not be reproduced (even extracts) unless prior written permission is granted. Every care has been taken to ensure the accuracy of the information contained in this publication but no liability can be accepted for any loss or damage whether direct, indirect or consequential arising out of the use of the information contained herein.

PUB BU/P2 14961/3 EN · November 2019

Certain image(s) used under license from Shutterstock.com.